

INVITATION TO BID
CITY OF NAPLES
PURCHASING DIVISION
CITY HALL, 735 8TH STREET SOUTH
NAPLES, FL 34102
PH: 239-213-7100 FX: 239-213-7105

Cover Sheet

NOTIFICATION DATE: 1/23/18	Decorative Street Signs RE-BID	SOLICITATION NUMBER: 18-029	OPENING DATE & TIME: 02/09/2018 2:00 PM
PRE-BID CONFERENCE DATE, TIME AND LOCATION: A non-mandatory Pre-Proposal conference will be held February 1, 2018 at 10:00 A.M. local time in the Purchasing Division located at 735 8th St – S, Naples FL, 34102			

LEGAL NAME OF PARTNERSHIP, CORPORATION OR INDIVIDUAL:		
MAILING ADDRESS:		
CITY-STATE-ZIP:		
PH:	EMAIL:	
FX:	WEB ADDRESS:	
AUTHORIZED SIGNATURE	DATE	PRINTED NAME/TITLE
<p>I certify that this bid is made without prior understanding, agreement, or connection with any corporation, firm, or person submitting a bid for the same materials, supplies, or equipment and is in all respects fair and without collusion or fraud. I agree to abide by all conditions of this bid and certify that I am authorized to sign this bid for the bidder. In submitting a bid to the City of Naples the bidder offers and agrees that if the bid is accepted, the bidder will convey, sell, assign or transfer to the City of Naples all rights, title, and interest in and to all causes of action it may now or hereafter acquire under the Anti-trust laws of the United States and the State of FL for price fixing relating to the particular commodities or services purchased or acquired by the City of Naples. At the City's discretion, such assignment shall be made and become effective at the time the City tenders final payment to the bidder.</p> <p style="text-align: center;">FEI/EIN Number _____</p> <p style="text-align: center; font-size: small;">Please initial by all that apply I acknowledge receipt/ review of the following addendum _____Addendum #1 _____Addendum #2 _____Addendum #3 _____Addendum #4</p>		

PLEASE NOTE THE FOLLOWING

- > **This page must be completed and returned with your bid.**
- > **Bids must be submitted in a sealed envelope, marked with solicitation number & opening date.**
- > **All submissions must be received and date stamped by Purchasing staff prior to the above "OPENING DATE & TIME".**
- > **Submission received after the above opening date and time will not be accepted.**
- > **Evaluation scores will be available on the City of Naples web site www.naplesgov.com . If you do not have computer access and want a copy of the evaluation scores, please enclose a stamped, self-addressed envelope with your bid.**

GENERAL CONDITIONS

TO ENSURE ACCEPTANCE OF THE PROPOSAL, PLEASE FOLLOW THESE INSTRUCTIONS. ANY AND ALL SPECIAL CONDITIONS, ATTACHED HERETO, HAVE PRECEDENCE.

- 1. SEALED PROPOSAL:** All proposals must be submitted in a sealed envelope. The face of the envelope shall contain the proposal name and proposal number. Proposals not submitted on attached cover form shall be rejected. All proposals are subject to the conditions specified herein. Those which do not comply with these conditions are subject to rejection.
- 2. EXECUTION OF PROPOSAL:** Proposal must contain a manual signature of authorized representative in the proposal section. Proposal must be typed or printed in ink. Use of erasable ink is not permitted. All corrections made by proposer to his proposal must be initialed.
- 3. NO PROPOSAL:** If not submitting a proposal, respond by returning the Statement of No Proposal and explain the reason in the spaces provided. Failure to respond 3 times in succession without justification shall be cause for removal of the supplier's name from the proposal mailing list. NOTE: To qualify as a respondent, proposer must submit a "NO PROPOSAL," and it must be received no later than the stated proposal opening date and hour.
- 4. PROPOSAL OPENING:** Shall be public, on the date and at the time specified on the proposal form. It is the proposer's responsibility to assure that his proposal is delivered at the proper time and place of the proposal opening. Proposals which for any reason are not so delivered will not be considered. Offers by telegram; telephone; or fax are not acceptable. Proposal files may be examined during normal working hours.
- 5. WITHDRAWAL OF PROPOSALS:** Withdrawal of a proposal within sixty (60) days after the opening of proposals is subject to suspension or debarment in accordance with Policy 7-4 for up to three years.
- 6. PRICES, TERMS and PAYMENT:** Firm Prices shall be proposal and include all packing, handling, shipping charges and delivery to the destination shown herein. Proposer is encouraged to offer cash discount for prompt invoice payment. Terms of less than 20 days will not be considered.

 - A. TAXES:** The City of Naples does not pay Federal Excise and Sales taxes on direct purchases of tangible personal property. See exemption number on face of purchase order. This exemption does not apply to purchases of tangible personal property made by contractors who use the tangible personal property in the performance of contracts for the improvement of City-owned real property.
 - B. MISTAKES:** Proposers are expected to examine the specifications, delivery schedule, proposal prices, extensions, and all instructions pertaining to supplies and services. Failure to do so will be at proposer's risk. In case of mistake in extension, the unit price will govern.
 - C. CONDITION AND PACKAGING:** It is understood and agreed that any item offered or shipped as a result of this proposal shall be a new, current standard production model available at the time of this proposal. All containers shall be suitable for storage or shipment, and all prices shall include standard commercial packaging.
 - D. SAFETY STANDARDS:** Unless otherwise stipulated in the proposal, all manufactured items and fabricated assemblies shall comply with applicable requirements of Occupational Safety and Health Act and any standards there under.
 - E. UNDERWRITERS' LABORATORIES:** Unless otherwise stipulated in the proposal, all manufactured items and fabricated assemblies shall carry U.L. approval and re-examination listing where such has been established.
 - F. PAYMENT:** Payment will be made by the buyer after the items awarded to a vendor have been received, inspected, and found to comply with award specifications, free of damage or defect and properly invoiced. All invoices shall bear the purchase order number. Payment for partial shipments shall not be made unless specified in the proposal. Failure to follow these instructions may result in delay in processing invoices for payment. In addition, the purchase order number must appear on bills of lading, packages, cases, delivery lists and correspondence.
- 7. DELIVERY:** Unless actual date of delivery is specified (or if specified delivery cannot be met), show number of days required to make delivery after receipt of purchase order in space provided. Delivery time may become a basis for making an award (see Special Conditions). Delivery shall be within the normal working hours of the user, Monday through Friday, unless otherwise specified.
- 8. MANUFACTURERS' NAMES AND APPROVED EQUIVALENTS:** Any manufacturers' names, trade names, brand names, information and/or catalog numbers listed in a specification are for information and not intended to limit competition. The proposer may offer any brand for which he is an authorized representative, which meets or

exceeds the specification for any item(s). If proposals are based on equivalent products, indicate on the proposal form the manufacturer's name and number. Proposer shall submit with his proposal, cuts, sketches, and descriptive literature, and/or complete specifications. Reference to literature submitted with a previous proposal will not satisfy this provision. The proposer shall also explain in detail the reason(s) why the proposed equivalent will meet the specifications and not be considered an exception thereto. Proposals which do not comply with these requirements are subject to rejection. Proposals lacking any written indication of intent to quote an alternate brand will be received and considered in complete compliance with the specifications as listed on the proposal form.

9. INTERPRETATIONS: Any questions concerning conditions and specifications shall be directed in writing to this office for receipt no later than ten (10) days prior to the proposal opening. Inquiries must reference the date of proposal opening and proposal number. Failure to comply with this condition will result in proposer waiving his right to dispute the proposal.

10. CONFLICT OF INTEREST: All proposal awards are subject to Section 2-973 Conflict of Interest, City of Naples Code of Ordinances, which states: *"No public officer or employee shall have or hold any employment or contractual relationship with any business entity or any agency which is subject to the regulation of or is doing business with the city; nor shall an officer or employee have or hold any employment or contractual relationship that will create a continuing or frequently recurring conflict between his private interests and the performance of his public duties or that would impede the full and faithful discharge of his public duties. Any member of the city council or any city officer or employee who willfully violates this section shall be guilty of malfeasance in office or position and shall forfeit his office or position. Violation of this section with the knowledge, express or implied, of the person or corporation contracting with or making a sale to the city shall render the contract or sale voidable by the city manager or the city council."*

11. AWARDS: As the best interest of the City may require, the right is reserved to make award(s) by individual item, group of items, all or none, or a combination thereof; to reject any and all proposals or waive any minor irregularity or technicality in proposals received.

12. ADDITIONAL QUANTITIES: For a period not exceeding ninety (90) days from the date of acceptance of this offer by the buyer, the right is reserved to acquire additional quantities up to but not exceeding those shown on proposal at the prices proposal in this invitation. If additional quantities are not acceptable, the proposal sheets must be noted "PROPOSAL IS FOR SPECIFIED QUANTITY ONLY." (THIS PARAGRAPH DOES NOT APPLY FOR A TERM CONTRACT.)

13. SERVICE AND WARRANTY: Unless otherwise specified, the proposer shall define any warranty service and replacements that will be provided during and subsequent to this contract. Proposers must explain on an attached sheet to what extent warranty and service facilities are provided.

14. SAMPLES: Samples of items, when called for, must be furnished free of expense, on or before proposal opening time and date, and if not destroyed may, upon request, be returned at the proposer's expense. Each individual sample must be labeled with proposer's name, manufacturer's brand name and number, proposal number and item reference. Request for return of samples shall be accompanied by instructions which include shipping authorization and name of carrier and must be received with your proposal. If instructions are not received within this time, the commodities shall be disposed of by the City of Naples.

15. PROPOSAL PROTEST: The city has formal proposal protest procedures that are available on request.

16. INSPECTION, ACCEPTANCE AND TITLE: Inspection and acceptance will be at destination unless otherwise provided. Title and risk of loss or damage to all items shall be the responsibility of the contract supplier until accepted by the ordering agency, unless loss or damage results from negligence by the ordering

17. DISPUTES: In case of any doubt or difference of opinion as to the items to be furnished hereunder, the decision of the buyer shall be final and binding on both parties.

18. GOVERNMENTAL RESTRICTIONS: In the event any governmental restrictions may be imposed which would necessitate alteration of the material, quality, workmanship or performance of the items offered on this proposal prior to their delivery, it shall be the responsibility of the successful proposer to notify the buyer at once, indicating in his letter the specific regulation which required an alteration. The City reserves the right to accept any such alteration, including any price adjustments occasioned thereby, or to cancel the contract at no expense to the City.

19. LEGAL REQUIREMENTS: Applicable provision of all Federal, State, county and local laws, and of all ordinances, rules, and regulations shall govern development submittal and evaluation of all proposals received in response hereto and shall govern any and all claims and disputes which may arise between person(s) submitting a proposal response hereto and the City of Naples by and through its officers, employees and authorized representatives, or any other person, natural or otherwise; and lack of knowledge by any proposer shall not constitute a cognizable defense against the legal effect thereof.

20. PATENTS AND ROYALTIES: The proposer, without exception, shall indemnify and save harmless the City of Naples and its employees from liability of any nature or kind, including cost and expenses for or on account of any copyrighted, patented, or unpatented invention, process, or article manufactured or used in the performance of the contract, including its use by the City of Naples. If the proposer uses any design, device, or materials covered by letters, patent or copyright, it is mutually agreed and understood without exception that the proposal prices shall include all royalties or cost arising from the use of such design, device, or materials in any way involved in the work.

21. ADVERTISING: In submitting a proposal, proposer agrees not to use the results there from as a part of any commercial advertising.

22. ASSIGNMENT: Any Purchase Order issued pursuant to this proposal invitation and the monies which may become due hereunder are not assignable except with the prior written approval of the buyer.

23. LIABILITY: The supplier shall hold and save the City of Naples, its officers, agents, and employees harmless from liability of any kind in the performance of this contract.

24. PUBLIC ENTITY CRIMES: A person or affiliate who has been placed on the convicted vendor list following a conviction for a public entity crime may not submit a proposal on a contract to provide any goods or services to a public entity, may not submit a proposal on a contract with a public entity for the construction or repair of a public building or public work, may not submit proposals on leases of real property to a public entity, may not be awarded or perform work as a contractor, supplier, subcontractor, or consultant under a contract with any public entity, and may not transact business with any public entity in excess of the threshold amount provided in Section 287.017, for CATEGORY TWO for a period of 36 months from the date of being placed on the convicted vendor list.

25. DISCRIMINATION: An entity or affiliate who has been placed on the discriminatory vendor list may not submit a proposal on a contract to provide goods or services to a public entity, may not submit a proposal on a contract with a public entity for the construction or repair of a public building or public work, may not submit proposals on leases of real property to a public entity, may not award or perform work as a contractor, supplier, subcontractor, or consultant under contract with any public entity, and may not transact business with any public entity.

26. COUNTY TAXES: No proposal shall be accepted from and no contract will be awarded to any person, firm or corporation that is in arrears to the government of Collier County, Florida.

27. OFFER EXTENDED TO OTHER GOVERNMENTAL ENTITIES: The City of Naples encourages and agrees to the successful proposer extending the pricing, terms and conditions of this solicitation or resultant contract to other governmental entities at the discretion of the successful proposer.

IF THIS PROPOSAL IS FOR A TERM CONTRACT, THE FOLLOWING CONDITIONS SHALL ALSO APPLY

28. ELIGIBLE USERS: All departments of the City of Naples are eligible to use this term contract. Such purchases shall be exempt from the competitive proposal requirements otherwise applying to their purchases.

29. PRICE ADJUSTMENTS: Any price decrease effectuated during the contract period by reason of market change shall be passed on to City of Naples. Price increases are not acceptable.

30. CANCELLATION: All contract obligations shall prevail for at least one hundred eighty (180) days after effective date of contract. After that period, for the protection of both parties, this contract may be cancelled in whole or in part by either party by giving thirty (30) days prior written notice to the other party.

31. RENEWAL: The City of Naples reserves the option to renew the period of this contract, or any portion thereof for up to two (2) additional periods. Renewal of the contract period shall be by mutual agreement in writing.

32. ABNORMAL QUANTITIES: While it is not anticipated, should any unusual or abnormal requirements arise, the City reserves the right to solicit separate proposals thereon.

33. FISCAL NON-FUNDING CLAUSE: In the event sufficient funds are not budgeted for a new fiscal period, the City shall notify the contractor of such occurrence and the contract shall terminate on the last day of the current fiscal year without penalty or expense to the City.

IF THIS PROPOSAL IS FOR PERFORMING A SERVICE, THE FOLLOWING CONDITIONS SHALL ALSO APPLY

34. ALTERNATIVE PROPOSALS: Proposers offering service delivery methods other than those permitted by the scope of work may submit a separate envelope clearly marked "ALTERNATIVE PROPOSAL". Alternative proposals will be deemed non-responsive and will not be considered for award. All such responses will, however, be examined prior to award. Such examination may result in cancellation of all proposals received to permit rewriting the scope of work to include the alternative method, or the alternative method may be considered for future requirements of the City of Naples.

35. ANTITRUST: By entering into a contract, the contractor conveys, sells, assigns and transfers to the City of Naples all rights, titles and interest it may now have or hereafter acquire under the antitrust laws of the United States and the State of Florida that relate to the particular goods or services purchased or acquired by the City of Naples under said contract.

36. PROPOSER INVESTIGATIONS: Before submitting a proposal, each proposer shall make all investigations and examinations necessary to ascertain all site conditions and requirements affecting the full performance of the contract and to verify any representations made by the City of Naples upon which the proposer will rely. If the proposer receives an award as a result of its proposal submission, failure to have made such investigations and examinations will in no way relieve the proposer from its obligation to comply in every detail with all provisions and requirements of the contract documents, nor will a plea of ignorance of such conditions and requirements be accepted as a basis for any claim whatsoever by the contractor for additional compensation.

37. CERTIFICATES AND LICENSES: The Contractor, at time of proposal, shall possess the correct occupational licenses, all professional licenses or other authorizations necessary to carry out and perform the work required by the City of Naples and Collier County for this project pursuant to all applicable Federal, State and Local Laws, Statutes, Ordinances, and rules and regulations of any kind.

38. CHANGE IN SCOPE OF WORK: The City of Naples may order changes in the work consisting of additions, deletions or other revisions within the general scope of the contract. No claims may be made by the contractor that the scope of the project or of the contractor's services has been changed, requiring changes to the amount of compensation to the contractor or other adjustments to the contract unless such changes or adjustments have been made by written amendment to the contract signed by the City of Naples and the contractor. If the contractor believes that any particular work is not within the scope of the project, is a material change, or will otherwise require more compensation to the contractor, the contractor must immediately notify the City in writing of this belief. If the City believes that the particular work is within the scope of the contract as written, the contractor will be ordered to and shall continue with the work as changed and at the cost stated for the work within the scope.

39. CONTRACTOR PERSONNEL: The City of Naples shall, throughout the life of the contract, have the right of reasonable rejection and approval of staff or subcontractors assigned to the work by the contractor. If the City reasonably rejects staff or subcontractors, the contractor must provide replacement staff or subcontractors satisfactory to the City in a timely manner and at no additional cost to the City. The day-to-day supervision and control of the contractor's employees and sub-contractors is the responsibility solely of the contractor.

40. COST REIMBURSEMENT: The contractor agrees that all incidental costs, including allowances for profit and tools of the trade, must be included in the proposal rates. If an arrangement is made between the contractor and the City to reimburse the contractor for the cost of materials provided in the performance of the work, the contractor shall be reimbursed in the following manner: The City shall reimburse the contractor on completion and acceptance of each assigned job, only for those materials actually used in the performance of the work that is supported by invoices issued by

the suppliers of the contractor describing the quantity and cost of the materials purchased. No surcharge shall be added to the supplier's invoices or included in the contractor's invoice submitted to the City that would increase the dollar amount indicated on the supplier's invoice for the materials purchased for the assigned job.

41. EXCEPTIONS: Proposers taking exception to any part or section of the solicitation shall indicate such exceptions on the proposal form. Failure to indicate any exception will be interpreted as the proposer's intent to comply fully with the requirements as written. Conditional or qualified proposals, unless specifically allowed, shall be subject to rejection in whole or in part.

42. FAILURE TO DELIVER: In the event of the contractor to fail to deliver services in accordance with the contract terms and conditions, the City, after due oral or written notice, may procure the services from other sources and hold the contractor responsible for any resulting purchase and administrative costs. This remedy shall be in addition to any other remedies that the City may have.

43. FAILURE TO ENFORCE: Failure by the City at any time to enforce the provisions of the contract shall not be construed as a waiver of any such provisions. Such failure to enforce shall not affect the validity of the contract or any part thereof or the right of the City to enforce any provision at any time in accordance with its terms.

44. FORCE MAJEURE: The contractor shall not be held responsible for failure to perform the duties and responsibilities imposed by the contract due to legal strikes, fires, riots, rebellions and acts of God beyond the control of the contractor, unless otherwise specified in the contract.

45. INDEPENDENT CONTRACTOR: The contractor shall be legally considered an independent contractor and neither the contractor nor its employees shall, under any circumstances, be considered servants or agents of the City of Naples and the City of Naples shall be at no time legally responsible for any negligence or any wrongdoing by the contractor, its servants or agents. The City of Naples shall not withhold from the contract payments to the contractor any federal income taxes, Social Security tax, or any other amounts for benefits to the contractor. Further, the City shall not provide to the contractor any insurance coverage or other benefits, including Workers' Compensation normally provided by the City for its employees.

46. ORAL STATEMENTS: No oral statement of any person shall modify or otherwise affect the terms, conditions or specifications stated in this contract. All modifications to the contract must be made in writing by the City of Naples.

47. QUALIFICATIONS OF PROPOSERS: The proposer may be required, before the award of any contract, to show to the complete satisfaction of the City of Naples that it has the necessary facilities, ability, and financial resources to provide the service specified therein in a satisfactory manner. The proposer may also be required to give a past history and references in order to satisfy the City in regard to the proposer's qualifications. The City may make reasonable investigations deemed necessary and proper to determine the ability of the proposer to perform the work, and the proposer shall furnish to the City all information for this purpose that may be requested. The City reserves the right to reject any proposal if the evidence submitted by, or investigation of, the proposer fails to satisfy the City that the proposer is properly qualified to carry out the obligations of the contract and to complete the work described therein. Evaluation of the proposer's qualifications shall include:

- > The ability, capacity, skill and financial resources to perform the work or service.
- > The ability to perform the work service promptly or within the time specified, without delay.
- > The character, integrity, reputation, judgment, experience, and efficiency of the proposer.
- > The quality of performance of previous contracts or services.

48. QUALITY CONTROL: The contractor shall institute and maintain throughout the contract period a properly documented quality control program designed to ensure that the services are provided at all times and in all respects in accordance with the contract. The program shall include providing daily supervision and conducting frequent inspections of the contractor's staff and ensuring that accurate records are maintained describing the disposition of all complaints. The records so created shall be open to inspection by the City.

49. RECOVERY OF MONEY: Whenever, under the contract, any sum of money shall be recoverable from or payable by the contractor to the City, the same amount may be deducted from any sum due to the contractor under the contract or under any other contract between the contractor and the City. The rights of the City are in addition and without prejudice to any other right the City may have to claim the amount of any loss or damage suffered by the City on account of the acts or omissions of the contractor.

50. REQUIREMENTS CONTRACT: During the period of the contract, the contractor shall provide all the services described in the contract. The contractor understands and agrees that this is a requirements contract and that the City shall have no obligation to the contractor if no services are required. Any quantities that are included in the scope of work reflect the current expectations of the City for the period of the contract. The amount is only an estimate and the contractor understands and agrees that the City is under no obligation to the contractor to buy any amount of services as a result of having provided this estimate or of having any typical or measurable requirement in the past. The contractor further understands and agrees that the City may require services in excess of the estimated annual contract amount and that the quantity actually used whether in excess of, or less than, the estimated annual contract amount and that the quantity actually used shall not give rise to any claim for compensation other than the total of the unit prices in the contract for the quantity actually used.

51. TERMINATION FOR CONVENIENCE: The performance of work under the contract may be terminated by the City in whole or in part whenever the City determines that termination is in the City's best interest. Any such termination shall be effected by the delivery to the contractor of a written notice of termination of at least seven (7) days before the date of termination, specifying the extent to which performance of the work under the contract is terminated and the date upon which such termination becomes effective. After receipt of a notice of termination, except as otherwise directed, the contractor shall stop work on the date of the receipt of the notice or other date specified in the notice; place no further orders or subcontracts for materials, services or facilities except as necessary for completion of such portion of the work not terminated; terminate all vendors and subcontracts; and settle all outstanding liabilities and claims.

52. TERMINATION FOR DEFAULT: The City of Naples reserves the right to terminate the contract if the City determines that the contractor has failed to perform satisfactorily the work required, as determined by the City. In the event the City decides to terminate the contract for failure to perform satisfactorily, the City shall give to the contractor at least seven (7) days written notice before the termination takes effect. The seven-day period will begin upon the mailing of notice by the City. If the contractor fails to cure the default within the seven (7) days specified in the notice and the contract is terminated for failure to perform satisfactorily, the contractor shall be entitled to receive compensation for all reasonable, allocable and allowable contract services satisfactorily performed by the contractor up to the date of termination that were accepted by the City prior to the termination. In the event the City terminates the contract because of the default of the contractor, the contractor shall be liable for all excess costs that the City is required to expend to complete the work under contract.

53. STATE AND FEDERAL EMPLOYMENT LAWS: Contractors providing service to the City are required to comply with all state and federal employment laws. This includes, but is not limited to, laws resulting from the Immigration and Reform and Control Act of 1986, wherein all employers are required to verify the identity and employment eligibility of all employees. The Department of Homeland Security, U.S. Citizenship and Immigration Services require employees and employers to complete Form I-9 and the employer must examine evidence of identity and employment eligibility within three business days of the date employment begins. Non compliant contractors will be subject to contract sanctions, up to and including contract termination.

54. CERTIFICATION REGARDING DEBARMENT, SUSPENSION, INELIGIBILITY, AND VOLUNTARY EXCLUSION: The contractor agrees to comply with Executive Order 12549 "Debarment and Suspension" and 2 CFR 180 "OMB Guidelines to Agencies on Government wide Debarment and Suspension." These rules require all contractors using federal funds not be debarred or suspended from doing business with the Federal Government. This includes sub-recipients and lower tier participant for covered transactions. Signing and submitting this document certified the organization and its principals are not presently debarred, suspended, proposed for debarment, declared ineligible, or voluntarily excluded from participation in this transaction by any federal department or agency, and further have not within the preceding three-year period been convicted of or had a civil judgment rendered against them for commission of fraud or a criminal offense in connection with obtaining, attempting to obtain, or performing a public (Federal, State or local) transaction.

THE CITY OF NAPLES IS AN EQUAL OPPORTUNITY EMPLOYER

GENERAL INSURANCE REQUIREMENTS

The Contractor shall not commence work until he has obtained all the insurance required under this heading, and until such insurance has been approved by the Owner, nor shall the Contractor allow any subcontractor to commence work until all similar insurance required of the subcontractor has also been obtained and approved by the Owner.

Certificates of insurance must be issued by an authorized representative of the insurance company at the request and direction of the policyholder and must include sufficient information so as to identify the coverage and the contract for Owner's improvements for which they are issued. Certificates of insurance must be issued by a nationally recognized insurance company with a Best's Rating of no less than B+VII, satisfactory to the Owner, and duly licensed to do business in the state of said Contract.

The Contractor shall procure and maintain, during the life of this Contract, Workmen's Compensation Insurance for all of his employees to be engaged in work under this Contract, and he shall require any subcontractor similarly to provide Workmen's Compensation Insurance for all of the latter's employees to be engaged in such work, unless such employees are covered by the protection afforded by the Contractor's insurance. In case any employees are to be engaged in hazardous work under this Contract, and are not protected under this Workmen's Compensation statute, the Contractor shall provide, and shall cause each subcontractor to provide, adequate coverage for the protection of such employees. It is acceptable to use a State-approved Workmen's Compensation Self-Insurance fund.

The Contractor shall take out and maintain during the life of this Contract, Public Liability and Property Damage and shall include Contractual Liability, Personal Injury, Libel, Slander, False Arrest, Malicious Prosecution, Wrongful Entry or Eviction, Broad Form Property Damage, Products, Completed Operations and XCU Coverage to be included on an occurrence basis, and to the full extent of the Contract to protect him, the Owner, and any subcontractor performing work covered by this Contract from damages for personal injury, including accidental death, as well as from claims for property damage, which may arise from operations under this contract, whether such operations be by himself or by a subcontractor, or by anyone directly or indirectly employed by either of them. The Contractor shall also maintain automobile liability insurance including "non-owned and hired" coverage. The entire cost of this insurance shall be borne by the Contractor.

The amount of such insurance shall be no less than \$1,000,000 annual aggregate for bodily injury and property damage combined per occurrence.

The City of Naples must be named as Additional Insured on the insurance certificate and the following must also be stated on the certificate. "These coverage's are primary to all other coverage's the City possesses for this contract only." The City of Naples shall be named as the Certificate Holder. The Certificate Holder shall read as follows:

The City of Naples
735 Eighth Street South
Naples, Florida 34102

No City Division, Department, or individual name should appear on the Certificate.
No other format will be acceptable.

The Certificate must state the solicitation number and title.

When using the ACORD 25 – Certificate of Insurance only the most current version will be accepted.

The City of Naples requires a copy of a cancellation notice in the event the policy is cancelled. The City of Naples shall be expressly endorsed onto the policy as a cancellation notice recipient.

Proof of insurance from the successful proposer is required at the time of issuance and award of a contract.

STATEMENT OF NO BID

If you will not be bidding on this product/service, please help us by completing and returning only this page to:

**City of Naples, Purchasing Division
City Hall, 735 8th Street South
Naples, FL 34102
Fax 239-213-7105**

Bid # _____ and Description: _____

We, the undersigned, decline to bid on the above project for the following reason(s):

- We are not able to respond to the Invitation to Bid by the specified deadline.**
- Our Company does not offer this product or service.**
- Our current work schedule will not permit us to perform the required services.**
- Specifications are incomplete or information is unclear
(Please explain below).**

Other (Please specify below)

Company Name _____

PH _____ **Email** _____

Name and Title of individual completing this form:

(Printed Name) **(Title)**

(Signature) **(Date)**

REFERENCES

THIS SHEET MUST BE COMPLETED AND RETURNED WITH BID

PROVIDE AT LEAST THREE NON-NAPLES REFERENCES FOR WHOM YOUR COMPANY HAS PROVIDED SAME OR SIMILAR SERVICES WITHIN THE LAST 2 YEARS.

COMPANY NAME: _____

ADDRESS: _____

TELEPHONE: _____

CONTACT PERSON: _____

CONTACT E-MAIL ADDRESS: _____

COMPANY NAME: _____

ADDRESS: _____

TELEPHONE: _____

CONTACT PERSON: _____

CONTACT E-MAIL ADDRESS: _____

COMPANY NAME: _____

ADDRESS: _____

TELEPHONE: _____

CONTACT PERSON: _____

CONTACT E-MAIL ADDRESS: _____

Submitting Vendor Name: _____

SPECIAL CONDITIONS

- A. **TERMS OF CONTRACT:** The resulting contract will commence on award and be in effect until completion of the project. The resultant contract will include the federal provisions found in Attachment A. Prices established by this bid shall be honored for a minimum of 24-months from the date the Agreement is executed by the City. The Contractor shall honor any order made by the City for any amount of decorative sign assemblies as allowed for by these specifications and at the rates set forth in the Bid Tabulation for a period of 12-months after the City's execution date of the Agreement. At the conclusion of the term of Agreement, the City and Contractor shall each have the option to extend the term of Agreement for two additional 12-month periods. As a method to assure completion of the total project, retainage in the amount of ten percent (10%) of all work completed will be withheld from the payment. The retainage will be released upon final inspection and project completion. Retention is required for any contract over \$200,000. **Should CONTRACTOR fail to complete the project within this timeframe specified, daily liquidated damages in an amount consistent with the current Sec. 8-10.2 Florida Department of Transportation Standard Specifications will be assessed.**
- B. **PROHIBITION OF CONTACT:** Under no circumstances should any prospective organization or individual, or anyone acting for or on behalf of a prospective organization or individual, seek to influence or gain the support of any member of the City Council, public official or City staff favorable to the interest of any prospective organization or individual. Likewise, contact with City Council, any public official or city staff against the interests of other prospective organization (s) and or individual(s) is prohibited. Any such activities will result in the exclusion of the prospective organization or individual from consideration by the City.
- C. **REFERENCES:** Bidder must submit a minimum of three references on the form provided. Additionally, a completed IRS W-9 form is required with the bid submission.
- D. **STATEMENT OF NO BID:** If you will not be bidding on this producer/service, please help us by completing and returning the Statement of No Bid.
- E. **BID FORMAT:** The Contract, if awarded, will be awarded on the basis of material and installation illustrated and described on the Drawings or specified in the Specification. If a substitution or an "or equal" item is proposed, Proposer must submit this information to the City of Naples Purchasing Department ten (10) days prior to the bid opening date for evaluation as an acceptable substitution or an "or equal" item. If the substitution or the "or equal" item is accepted, the City of Naples will issue an Addendum to all Proposers listing the allowable substitution or the "or equal" item or method. The cost of changes in related work, additional drawings which may be required to illustrate or define the substitute or "or equal" equipment and its relationship to the other parts or portions of the Work shall be paid by the Contractor. No change will be made in the amount of time in which to complete the Work. **NOTE: The City will be allowed to negotiate on final pricing with the lowest responsive bidder and the City may review and accept/deny alternate bids that modify the design**

specifications or installation process as part of the “or equal” item or method stated above in this section.

- F. **BID SECURITY / BID BOND / BID GUARANTEE:** It is the policy of the City of Naples to require a Bid Bond for all construction-related sealed bids estimated to be in excess of \$100,000. A bid bond or equivalent financial security in the amount of five (5) percent of the bid price shall be required and must accompany all bids. The Bid Bond is to be provided by a surety company authorized to do business in the State of Florida or otherwise supplied in a form satisfactory to the City. The bid bond must be submitted with the bid. When the invitation for bids requires a bid bond, noncompliance will result in rejection of the bid. Note that failure or refusal of the awarded bidder to enter into a contract within twenty (20) calendar days after receipt of said contract will result in damages to the City and bid bond will be forfeited to the City as liquidated damages.
- G. **PROPOSAL CONSTRUCTION PERFORMANCE & PAYMENT BONDS:** A Performance and Payment Bond will be required of the Awarded Proposer for any contract that is in excess of \$100,000.00 dollars and will be in an amount equal to 100 (%) percent of the price specified in the Contract. The bond(s) shall be executed by a surety company authorized to do business in the State of Florida, or otherwise secured in a manner satisfactory to the City for the protection of all persons supplying labor and material to the contractor or its subcontractors for the performance of the work provided for in the contract.
- H. **QUESTIONS:** Questions regarding this proposer packet must be received in writing in the Purchasing Division, NO LATER THAN TEN CALENDAR DAYS PRIOR TO THE PROPOSAL OPENING DATE TO ENSURE AN ANSWER IS PROVIDED PRIOR TO CLOSING.

Direct all questions to:

Gerald “Jed” Secory, MBA / CPPO / CPM
Purchasing Manager
City of Naples, Purchasing Division
735 8th Street South
Naples, Florida 34102
PH: (239) 213-7102 FX: (239) 213-7105
Jsecory@naplesgov.com

SUBMISSION CHECKLIST

Bidder should check off each of the following items as completed and submit with bid response:

CHECKLIST ELEMENTS	INCLUDED
<ul style="list-style-type: none"> Submit one (1) original signature and one (1) copy of your original bid / document AND a Windows© compatible PDF of the original document on a CD or Flash / Thumb Drive that is clearly labeled. 	
<ul style="list-style-type: none"> Include any required drawings; descriptive literature; qualifications; schedules; product compliance / exceptions; alternatives; questionnaire; references, forms, tabs, pricing/cost; and any information required of the proposer identified in the text of the bid including information for bid evaluation. 	
<ul style="list-style-type: none"> Include any Professional Licenses that qualify the firm for this solicitation as well as applicable bond documents, if required. Note if you are not a single prime contractor. List all subcontractors to be used for our project in your bid/proposal and their professional licenses. 	
<ul style="list-style-type: none"> Mandatory FORMS from this document to be included are: <u>Cover Sheet</u>, <u>References Sheet</u>, <u>Submission Checklist Sheet</u>, <u>IRS W-9</u> (Dec 2014) and <u>Cost / Price Schedule</u>. 	
<ul style="list-style-type: none"> Have an authorized individual sign the appropriate pages including the <u>Cover Sheet</u> with bid addenda initialed. 	
<ul style="list-style-type: none"> Bid document needs to be received by the OPENING DATE & TIME indicated on the Cover Sheet. The mailing envelope must be addressed to: <div style="text-align: center;"> City of Naples Purchasing Division 735 8th Street South Naples, Florida 34102 </div> 	
<p style="text-align: center;">The mailing envelope should be sealed and marked with:</p> Number: ITB 18-029 Title: RE-BID Decorative Street Signs Opening Date: 02/09/2018	

ALL COURIER DELIVERED BIDS MUST HAVE THE BID NUMBER AND TITLE ON THE OUTSIDE OF THE COURIER PACKET.

Submitting Vendor Name: _____

At the discretion of the Purchasing Manager, bids or proposals with minor irregularities may be accepted and allowed to be corrected when in the best interest of the City.

Request for Taxpayer Identification Number and Certification

**Give Form to the
 requester. Do not
 send to the IRS.**

▶ Go to www.irs.gov/FormW9 for instructions and the latest information.

Print or type.
See Specific Instructions on page 3.

1 Name (as shown on your income tax return). Name is required on this line; do not leave this line blank.
2 Business name/disregarded entity name, if different from above
3 Check appropriate box for federal tax classification of the person whose name is entered on line 1. Check only one of the following seven boxes. <input type="checkbox"/> Individual/sole proprietor or single-member LLC <input type="checkbox"/> C Corporation <input type="checkbox"/> S Corporation <input type="checkbox"/> Partnership <input type="checkbox"/> Trust/estate <input type="checkbox"/> Limited liability company. Enter the tax classification (C=C corporation, S=S corporation, P=Partnership) ▶ _____ Note: Check the appropriate box in the line above for the tax classification of the single-member owner. Do not check LLC if the LLC is classified as a single-member LLC that is disregarded from the owner unless the owner of the LLC is another LLC that is not disregarded from the owner for U.S. federal tax purposes. Otherwise, a single-member LLC that is disregarded from the owner should check the appropriate box for the tax classification of its owner. <input type="checkbox"/> Other (see instructions) ▶ _____
4 Exemptions (codes apply only to certain entities, not individuals; see instructions on page 3): Exempt payee code (if any) _____ Exemption from FATCA reporting code (if any) _____ <i>(Applies to accounts maintained outside the U.S.)</i>
5 Address (number, street, and apt. or suite no.) See instructions.
6 City, state, and ZIP code
7 List account number(s) here (optional)
Requester's name and address (optional)

Part I Taxpayer Identification Number (TIN)

Enter your TIN in the appropriate box. The TIN provided must match the name given on line 1 to avoid backup withholding. For individuals, this is generally your social security number (SSN). However, for a resident alien, sole proprietor, or disregarded entity, see the instructions for Part I, later. For other entities, it is your employer identification number (EIN). If you do not have a number, see *How to get a TIN*, later.

Note: If the account is in more than one name, see the instructions for line 1. Also see *What Name and Number To Give the Requester* for guidelines on whose number to enter.

Social security number									
<table style="width: 100%; border-collapse: collapse;"> <tr> <td style="width: 25%; border: 1px solid black; height: 20px;"></td> <td style="width: 5%; text-align: center;">-</td> <td style="width: 25%; border: 1px solid black; height: 20px;"></td> <td style="width: 5%; text-align: center;">-</td> <td style="width: 40%; border: 1px solid black; height: 20px;"></td> </tr> </table>		-		-					
	-		-						
or									
Employer identification number									
<table style="width: 100%; border-collapse: collapse;"> <tr> <td style="width: 10%; border: 1px solid black; height: 20px;"></td> <td style="width: 5%; text-align: center;">-</td> <td style="width: 15%; border: 1px solid black; height: 20px;"></td> <td style="width: 5%; text-align: center;">-</td> <td style="width: 15%; border: 1px solid black; height: 20px;"></td> <td style="width: 5%; text-align: center;">-</td> <td style="width: 15%; border: 1px solid black; height: 20px;"></td> <td style="width: 5%; text-align: center;">-</td> <td style="width: 15%; border: 1px solid black; height: 20px;"></td> </tr> </table>		-		-		-		-	
	-		-		-		-		

Part II Certification

Under penalties of perjury, I certify that:

- The number shown on this form is my correct taxpayer identification number (or I am waiting for a number to be issued to me); and
- I am not subject to backup withholding because: (a) I am exempt from backup withholding, or (b) I have not been notified by the Internal Revenue Service (IRS) that I am subject to backup withholding as a result of a failure to report all interest or dividends, or (c) the IRS has notified me that I am no longer subject to backup withholding; and
- I am a U.S. citizen or other U.S. person (defined below); and
- The FATCA code(s) entered on this form (if any) indicating that I am exempt from FATCA reporting is correct.

Certification instructions. You must cross out item 2 above if you have been notified by the IRS that you are currently subject to backup withholding because you have failed to report all interest and dividends on your tax return. For real estate transactions, item 2 does not apply. For mortgage interest paid, acquisition or abandonment of secured property, cancellation of debt, contributions to an individual retirement arrangement (IRA), and generally, payments other than interest and dividends, you are not required to sign the certification, but you must provide your correct TIN. See the instructions for Part II, later.

Sign Here	Signature of U.S. person ▶	Date ▶
------------------	----------------------------	--------

General Instructions

Section references are to the Internal Revenue Code unless otherwise noted.

Future developments. For the latest information about developments related to Form W-9 and its instructions, such as legislation enacted after they were published, go to www.irs.gov/FormW9.

Purpose of Form

An individual or entity (Form W-9 requester) who is required to file an information return with the IRS must obtain your correct taxpayer identification number (TIN) which may be your social security number (SSN), individual taxpayer identification number (ITIN), adoption taxpayer identification number (ATIN), or employer identification number (EIN), to report on an information return the amount paid to you, or other amount reportable on an information return. Examples of information returns include, but are not limited to, the following.

- Form 1099-INT (interest earned or paid)

- Form 1099-DIV (dividends, including those from stocks or mutual funds)
 - Form 1099-MISC (various types of income, prizes, awards, or gross proceeds)
 - Form 1099-B (stock or mutual fund sales and certain other transactions by brokers)
 - Form 1099-S (proceeds from real estate transactions)
 - Form 1099-K (merchant card and third party network transactions)
 - Form 1098 (home mortgage interest), 1098-E (student loan interest), 1098-T (tuition)
 - Form 1099-C (canceled debt)
 - Form 1099-A (acquisition or abandonment of secured property)
- Use Form W-9 only if you are a U.S. person (including a resident alien), to provide your correct TIN.

If you do not return Form W-9 to the requester with a TIN, you might be subject to backup withholding. See What is backup withholding, later.

By signing the filled-out form, you:

1. Certify that the TIN you are giving is correct (or you are waiting for a number to be issued),
2. Certify that you are not subject to backup withholding, or
3. Claim exemption from backup withholding if you are a U.S. exempt payee. If applicable, you are also certifying that as a U.S. person, your allocable share of any partnership income from a U.S. trade or business is not subject to the withholding tax on foreign partners' share of effectively connected income, and
4. Certify that FATCA code(s) entered on this form (if any) indicating that you are exempt from the FATCA reporting, is correct. See *What is FATCA reporting*, later, for further information.

Note: If you are a U.S. person and a requester gives you a form other than Form W-9 to request your TIN, you must use the requester's form if it is substantially similar to this Form W-9.

Definition of a U.S. person. For federal tax purposes, you are considered a U.S. person if you are:

- An individual who is a U.S. citizen or U.S. resident alien;
- A partnership, corporation, company, or association created or organized in the United States or under the laws of the United States;
- An estate (other than a foreign estate); or
- A domestic trust (as defined in Regulations section 301.7701-7).

Special rules for partnerships. Partnerships that conduct a trade or business in the United States are generally required to pay a withholding tax under section 1446 on any foreign partners' share of effectively connected taxable income from such business. Further, in certain cases where a Form W-9 has not been received, the rules under section 1446 require a partnership to presume that a partner is a foreign person, and pay the section 1446 withholding tax. Therefore, if you are a U.S. person that is a partner in a partnership conducting a trade or business in the United States, provide Form W-9 to the partnership to establish your U.S. status and avoid section 1446 withholding on your share of partnership income.

In the cases below, the following person must give Form W-9 to the partnership for purposes of establishing its U.S. status and avoiding withholding on its allocable share of net income from the partnership conducting a trade or business in the United States.

- In the case of a disregarded entity with a U.S. owner, the U.S. owner of the disregarded entity and not the entity;
- In the case of a grantor trust with a U.S. grantor or other U.S. owner, generally, the U.S. grantor or other U.S. owner of the grantor trust and not the trust; and
- In the case of a U.S. trust (other than a grantor trust), the U.S. trust (other than a grantor trust) and not the beneficiaries of the trust.

Foreign person. If you are a foreign person or the U.S. branch of a foreign bank that has elected to be treated as a U.S. person, do not use Form W-9. Instead, use the appropriate Form W-8 or Form 8233 (see Pub. 515, *Withholding of Tax on Nonresident Aliens and Foreign Entities*).

Nonresident alien who becomes a resident alien. Generally, only a nonresident alien individual may use the terms of a tax treaty to reduce or eliminate U.S. tax on certain types of income. However, most tax treaties contain a provision known as a "saving clause." Exceptions specified in the saving clause may permit an exemption from tax to continue for certain types of income even after the payee has otherwise become a U.S. resident alien for tax purposes.

If you are a U.S. resident alien who is relying on an exception contained in the saving clause of a tax treaty to claim an exemption from U.S. tax on certain types of income, you must attach a statement to Form W-9 that specifies the following five items.

1. The treaty country. Generally, this must be the same treaty under which you claimed exemption from tax as a nonresident alien.
2. The treaty article addressing the income.
3. The article number (or location) in the tax treaty that contains the saving clause and its exceptions.
4. The type and amount of income that qualifies for the exemption from tax.
5. Sufficient facts to justify the exemption from tax under the terms of the treaty article.

Example. Article 20 of the U.S.-China income tax treaty allows an exemption from tax for scholarship income received by a Chinese student temporarily present in the United States. Under U.S. law, this student will become a resident alien for tax purposes if his or her stay in the United States exceeds 5 calendar years. However, paragraph 2 of the first Protocol to the U.S.-China treaty (dated April 30, 1984) allows the provisions of Article 20 to continue to apply even after the Chinese student becomes a resident alien of the United States. A Chinese student who qualifies for this exception (under paragraph 2 of the first protocol) and is relying on this exception to claim an exemption from tax on his or her scholarship or fellowship income would attach to Form W-9 a statement that includes the information described above to support that exemption.

If you are a nonresident alien or a foreign entity, give the requester the appropriate completed Form W-8 or Form 8233.

Backup Withholding

What is backup withholding? Persons making certain payments to you must under certain conditions withhold and pay to the IRS 28% of such payments. This is called "backup withholding." Payments that may be subject to backup withholding include interest, tax-exempt interest, dividends, broker and barter exchange transactions, rents, royalties, nonemployee pay, payments made in settlement of payment card and third party network transactions, and certain payments from fishing boat operators. Real estate transactions are not subject to backup withholding.

You will not be subject to backup withholding on payments you receive if you give the requester your correct TIN, make the proper certifications, and report all your taxable interest and dividends on your tax return.

Payments you receive will be subject to backup withholding if:

1. You do not furnish your TIN to the requester,
2. You do not certify your TIN when required (see the instructions for Part II for details),
3. The IRS tells the requester that you furnished an incorrect TIN,
4. The IRS tells you that you are subject to backup withholding because you did not report all your interest and dividends on your tax return (for reportable interest and dividends only), or
5. You do not certify to the requester that you are not subject to backup withholding under 4 above (for reportable interest and dividend accounts opened after 1983 only).

Certain payees and payments are exempt from backup withholding. See *Exempt payee code*, later, and the separate Instructions for the Requester of Form W-9 for more information.

Also see *Special rules for partnerships*, earlier.

What is FATCA Reporting?

The Foreign Account Tax Compliance Act (FATCA) requires a participating foreign financial institution to report all United States account holders that are specified United States persons. Certain payees are exempt from FATCA reporting. See *Exemption from FATCA reporting code*, later, and the Instructions for the Requester of Form W-9 for more information.

Updating Your Information

You must provide updated information to any person to whom you claimed to be an exempt payee if you are no longer an exempt payee and anticipate receiving reportable payments in the future from this person. For example, you may need to provide updated information if you are a C corporation that elects to be an S corporation, or if you no longer are tax exempt. In addition, you must furnish a new Form W-9 if the name or TIN changes for the account; for example, if the grantor of a grantor trust dies.

Penalties

Failure to furnish TIN. If you fail to furnish your correct TIN to a requester, you are subject to a penalty of \$50 for each such failure unless your failure is due to reasonable cause and not to willful neglect.

Civil penalty for false information with respect to withholding. If you make a false statement with no reasonable basis that results in no backup withholding, you are subject to a \$500 penalty.

Criminal penalty for falsifying information. Willfully falsifying certifications or affirmations may subject you to criminal penalties including fines and/or imprisonment.

Misuse of TINs. If the requester discloses or uses TINs in violation of federal law, the requester may be subject to civil and criminal penalties.

Specific Instructions

Line 1

You must enter one of the following on this line; **do not** leave this line blank. The name should match the name on your tax return.

If this Form W-9 is for a joint account (other than an account maintained by a foreign financial institution (FFI)), list first, and then circle, the name of the person or entity whose number you entered in Part I of Form W-9. If you are providing Form W-9 to an FFI to document a joint account, each holder of the account that is a U.S. person must provide a Form W-9.

a. Individual. Generally, enter the name shown on your tax return. If you have changed your last name without informing the Social Security Administration (SSA) of the name change, enter your first name, the last name as shown on your social security card, and your new last name.

Note: ITIN applicant: Enter your individual name as it was entered on your Form W-7 application, line 1a. This should also be the same as the name you entered on the Form 1040/1040A/1040EZ you filed with your application.

b. Sole proprietor or single-member LLC. Enter your individual name as shown on your 1040/1040A/1040EZ on line 1. You may enter your business, trade, or "doing business as" (DBA) name on line 2.

c. Partnership, LLC that is not a single-member LLC, C corporation, or S corporation. Enter the entity's name as shown on the entity's tax return on line 1 and any business, trade, or DBA name on line 2.

d. Other entities. Enter your name as shown on required U.S. federal tax documents on line 1. This name should match the name shown on the charter or other legal document creating the entity. You may enter any business, trade, or DBA name on line 2.

e. Disregarded entity. For U.S. federal tax purposes, an entity that is disregarded as an entity separate from its owner is treated as a "disregarded entity." See Regulations section 301.7701-2(c)(2)(iii). Enter the owner's name on line 1. The name of the entity entered on line 1 should never be a disregarded entity. The name on line 1 should be the name shown on the income tax return on which the income should be reported. For example, if a foreign LLC that is treated as a disregarded entity for U.S. federal tax purposes has a single owner that is a U.S. person, the U.S. owner's name is required to be provided on line 1. If the direct owner of the entity is also a disregarded entity, enter the first owner that is not disregarded for federal tax purposes. Enter the disregarded entity's name on line 2, "Business name/disregarded entity name." If the owner of the disregarded entity is a foreign person, the owner must complete an appropriate Form W-8 instead of a Form W-9. This is the case even if the foreign person has a U.S. TIN.

Line 2

If you have a business name, trade name, DBA name, or disregarded entity name, you may enter it on line 2.

Line 3

Check the appropriate box on line 3 for the U.S. federal tax classification of the person whose name is entered on line 1. Check only one box on line 3.

IF the entity/person on line 1 is a(n) . . .	THEN check the box for . . .
• Corporation	Corporation
• Individual • Sole proprietorship, or • Single-member limited liability company (LLC) owned by an individual and disregarded for U.S. federal tax purposes.	Individual/sole proprietor or single-member LLC
• LLC treated as a partnership for U.S. federal tax purposes, • LLC that has filed Form 8832 or 2553 to be taxed as a corporation, or • LLC that is disregarded as an entity separate from its owner but the owner is another LLC that is not disregarded for U.S. federal tax purposes.	Limited liability company and enter the appropriate tax classification. (P= Partnership; C= C corporation; or S= S corporation)
• Partnership	Partnership
• Trust/estate	Trust/estate

Line 4, Exemptions

If you are exempt from backup withholding and/or FATCA reporting, enter in the appropriate space on line 4 any code(s) that may apply to you.

Exempt payee code.

- Generally, individuals (including sole proprietors) are not exempt from backup withholding.
- Except as provided below, corporations are exempt from backup withholding for certain payments, including interest and dividends.
- Corporations are not exempt from backup withholding for payments made in settlement of payment card or third party network transactions.
- Corporations are not exempt from backup withholding with respect to attorneys' fees or gross proceeds paid to attorneys, and corporations that provide medical or health care services are not exempt with respect to payments reportable on Form 1099-MISC.

The following codes identify payees that are exempt from backup withholding. Enter the appropriate code in the space in line 4.

- 1—An organization exempt from tax under section 501(a), any IRA, or a custodial account under section 403(b)(7) if the account satisfies the requirements of section 401(f)(2)
- 2—The United States or any of its agencies or instrumentalities
- 3—A state, the District of Columbia, a U.S. commonwealth or possession, or any of their political subdivisions or instrumentalities
- 4—A foreign government or any of its political subdivisions, agencies, or instrumentalities
- 5—A corporation
- 6—A dealer in securities or commodities required to register in the United States, the District of Columbia, or a U.S. commonwealth or possession
- 7—A futures commission merchant registered with the Commodity Futures Trading Commission
- 8—A real estate investment trust
- 9—An entity registered at all times during the tax year under the Investment Company Act of 1940
- 10—A common trust fund operated by a bank under section 584(a)
- 11—A financial institution
- 12—A middleman known in the investment community as a nominee or custodian
- 13—A trust exempt from tax under section 664 or described in section 4947

The following chart shows types of payments that may be exempt from backup withholding. The chart applies to the exempt payees listed above, 1 through 13.

IF the payment is for . . .	THEN the payment is exempt for . . .
Interest and dividend payments	All exempt payees except for 7
Broker transactions	Exempt payees 1 through 4 and 6 through 11 and all C corporations. S corporations must not enter an exempt payee code because they are exempt only for sales of noncovered securities acquired prior to 2012.
Barter exchange transactions and patronage dividends	Exempt payees 1 through 4
Payments over \$600 required to be reported and direct sales over \$5,000 ¹	Generally, exempt payees 1 through 5 ²
Payments made in settlement of payment card or third party network transactions	Exempt payees 1 through 4

¹ See Form 1099-MISC, Miscellaneous Income, and its instructions.

² However, the following payments made to a corporation and reportable on Form 1099-MISC are not exempt from backup withholding: medical and health care payments, attorneys' fees, gross proceeds paid to an attorney reportable under section 6045(f), and payments for services paid by a federal executive agency.

Exemption from FATCA reporting code. The following codes identify payees that are exempt from reporting under FATCA. These codes apply to persons submitting this form for accounts maintained outside of the United States by certain foreign financial institutions. Therefore, if you are only submitting this form for an account you hold in the United States, you may leave this field blank. Consult with the person requesting this form if you are uncertain if the financial institution is subject to these requirements. A requester may indicate that a code is not required by providing you with a Form W-9 with "Not Applicable" (or any similar indication) written or printed on the line for a FATCA exemption code.

A—An organization exempt from tax under section 501(a) or any individual retirement plan as defined in section 7701(a)(37)

B—The United States or any of its agencies or instrumentalities

C—A state, the District of Columbia, a U.S. commonwealth or possession, or any of their political subdivisions or instrumentalities

D—A corporation the stock of which is regularly traded on one or more established securities markets, as described in Regulations section 1.1472-1(c)(1)(i)

E—A corporation that is a member of the same expanded affiliated group as a corporation described in Regulations section 1.1472-1(c)(1)(i)

F—A dealer in securities, commodities, or derivative financial instruments (including notional principal contracts, futures, forwards, and options) that is registered as such under the laws of the United States or any state

G—A real estate investment trust

H—A regulated investment company as defined in section 851 or an entity registered at all times during the tax year under the Investment Company Act of 1940

I—A common trust fund as defined in section 584(a)

J—A bank as defined in section 581

K—A broker

L—A trust exempt from tax under section 664 or described in section 4947(a)(1)

M—A tax exempt trust under a section 403(b) plan or section 457(g) plan

Note: You may wish to consult with the financial institution requesting this form to determine whether the FATCA code and/or exempt payee code should be completed.

Line 5

Enter your address (number, street, and apartment or suite number). This is where the requester of this Form W-9 will mail your information returns. If this address differs from the one the requester already has on file, write NEW at the top. If a new address is provided, there is still a chance the old address will be used until the payor changes your address in their records.

Line 6

Enter your city, state, and ZIP code.

Part I. Taxpayer Identification Number (TIN)

Enter your TIN in the appropriate box. If you are a resident alien and you do not have and are not eligible to get an SSN, your TIN is your IRS individual taxpayer identification number (ITIN). Enter it in the social security number box. If you do not have an ITIN, see *How to get a TIN* below.

If you are a sole proprietor and you have an EIN, you may enter either your SSN or EIN.

If you are a single-member LLC that is disregarded as an entity separate from its owner, enter the owner's SSN (or EIN, if the owner has one). Do not enter the disregarded entity's EIN. If the LLC is classified as a corporation or partnership, enter the entity's EIN.

Note: See *What Name and Number To Give the Requester*, later, for further clarification of name and TIN combinations.

How to get a TIN. If you do not have a TIN, apply for one immediately. To apply for an SSN, get Form SS-5, Application for a Social Security Card, from your local SSA office or get this form online at www.SSA.gov. You may also get this form by calling 1-800-772-1213. Use Form W-7, Application for IRS Individual Taxpayer Identification Number, to apply for an ITIN, or Form SS-4, Application for Employer Identification Number, to apply for an EIN. You can apply for an EIN online by accessing the IRS website at www.irs.gov/Businesses and clicking on Employer Identification Number (EIN) under Starting a Business. Go to www.irs.gov/Forms to view, download, or print Form W-7 and/or Form SS-4. Or, you can go to www.irs.gov/OrderForms to place an order and have Form W-7 and/or SS-4 mailed to you within 10 business days.

If you are asked to complete Form W-9 but do not have a TIN, apply for a TIN and write "Applied For" in the space for the TIN, sign and date the form, and give it to the requester. For interest and dividend payments, and certain payments made with respect to readily tradable instruments, generally you will have 60 days to get a TIN and give it to the requester before you are subject to backup withholding on payments. The 60-day rule does not apply to other types of payments. You will be subject to backup withholding on all such payments until you provide your TIN to the requester.

Note: Entering "Applied For" means that you have already applied for a TIN or that you intend to apply for one soon.

Caution: A disregarded U.S. entity that has a foreign owner must use the appropriate Form W-8.

Part II. Certification

To establish to the withholding agent that you are a U.S. person, or resident alien, sign Form W-9. You may be requested to sign by the withholding agent even if item 1, 4, or 5 below indicates otherwise.

For a joint account, only the person whose TIN is shown in Part I should sign (when required). In the case of a disregarded entity, the person identified on line 1 must sign. Exempt payees, see *Exempt payee code*, earlier.

Signature requirements. Complete the certification as indicated in items 1 through 5 below.

1. Interest, dividend, and barter exchange accounts opened before 1984 and broker accounts considered active during 1983. You must give your correct TIN, but you do not have to sign the certification.

2. Interest, dividend, broker, and barter exchange accounts opened after 1983 and broker accounts considered inactive during 1983. You must sign the certification or backup withholding will apply. If you are subject to backup withholding and you are merely providing your correct TIN to the requester, you must cross out item 2 in the certification before signing the form.

3. Real estate transactions. You must sign the certification. You may cross out item 2 of the certification.

4. Other payments. You must give your correct TIN, but you do not have to sign the certification unless you have been notified that you have previously given an incorrect TIN. "Other payments" include payments made in the course of the requester's trade or business for rents, royalties, goods (other than bills for merchandise), medical and health care services (including payments to corporations), payments to a nonemployee for services, payments made in settlement of payment card and third party network transactions, payments to certain fishing boat crew members and fishermen, and gross proceeds paid to attorneys (including payments to corporations).

5. Mortgage interest paid by you, acquisition or abandonment of secured property, cancellation of debt, qualified tuition program payments (under section 529), ABLE accounts (under section 529A), IRA, Coverdell ESA, Archer MSA or HSA contributions or distributions, and pension distributions. You must give your correct TIN, but you do not have to sign the certification.

What Name and Number To Give the Requester

For this type of account:	Give name and SSN of:
1. Individual	The individual
2. Two or more individuals (joint account) other than an account maintained by an FFI	The actual owner of the account or, if combined funds, the first individual on the account ¹
3. Two or more U.S. persons (joint account maintained by an FFI)	Each holder of the account
4. Custodial account of a minor (Uniform Gift to Minors Act)	The minor ²
5. a. The usual revocable savings trust (grantor is also trustee) b. So-called trust account that is not a legal or valid trust under state law	The grantor-trustee ¹ The actual owner ¹
6. Sole proprietorship or disregarded entity owned by an individual	The owner ³
7. Grantor trust filing under Optional Form 1099 Filing Method 1 (see Regulations section 1.671-4(b)(2)(i)(A))	The grantor ⁴
For this type of account:	Give name and EIN of:
8. Disregarded entity not owned by an individual	The owner
9. A valid trust, estate, or pension trust	Legal entity ⁴
10. Corporation or LLC electing corporate status on Form 8832 or Form 2553	The corporation
11. Association, club, religious, charitable, educational, or other tax-exempt organization	The organization
12. Partnership or multi-member LLC	The partnership
13. A broker or registered nominee	The broker or nominee

For this type of account:	Give name and EIN of:
14. Account with the Department of Agriculture in the name of a public entity (such as a state or local government, school district, or prison) that receives agricultural program payments	The public entity
15. Grantor trust filing under the Form 1041 Filing Method or the Optional Form 1099 Filing Method 2 (see Regulations section 1.671-4(b)(2)(i)(B))	The trust

¹ List first and circle the name of the person whose number you furnish. If only one person on a joint account has an SSN, that person's number must be furnished.

² Circle the minor's name and furnish the minor's SSN.

³ You must show your individual name and you may also enter your business or DBA name on the "Business name/disregarded entity" name line. You may use either your SSN or EIN (if you have one), but the IRS encourages you to use your SSN.

⁴ List first and circle the name of the trust, estate, or pension trust. (Do not furnish the TIN of the personal representative or trustee unless the legal entity itself is not designated in the account title.) Also see *Special rules for partnerships*, earlier.

***Note:** The grantor also must provide a Form W-9 to trustee of trust.

Note: If no name is circled when more than one name is listed, the number will be considered to be that of the first name listed.

Secure Your Tax Records From Identity Theft

Identity theft occurs when someone uses your personal information such as your name, SSN, or other identifying information, without your permission, to commit fraud or other crimes. An identity thief may use your SSN to get a job or may file a tax return using your SSN to receive a refund.

To reduce your risk:

- Protect your SSN,
- Ensure your employer is protecting your SSN, and
- Be careful when choosing a tax preparer.

If your tax records are affected by identity theft and you receive a notice from the IRS, respond right away to the name and phone number printed on the IRS notice or letter.

If your tax records are not currently affected by identity theft but you think you are at risk due to a lost or stolen purse or wallet, questionable credit card activity or credit report, contact the IRS Identity Theft Hotline at 1-800-908-4490 or submit Form 14039.

For more information, see Pub. 5027, Identity Theft Information for Taxpayers.

Victims of identity theft who are experiencing economic harm or a systemic problem, or are seeking help in resolving tax problems that have not been resolved through normal channels, may be eligible for Taxpayer Advocate Service (TAS) assistance. You can reach TAS by calling the TAS toll-free case intake line at 1-877-777-4778 or TTY/TDD 1-800-829-4059.

Protect yourself from suspicious emails or phishing schemes.

Phishing is the creation and use of email and websites designed to mimic legitimate business emails and websites. The most common act is sending an email to a user falsely claiming to be an established legitimate enterprise in an attempt to scam the user into surrendering private information that will be used for identity theft.

The IRS does not initiate contacts with taxpayers via emails. Also, the IRS does not request personal detailed information through email or ask taxpayers for the PIN numbers, passwords, or similar secret access information for their credit card, bank, or other financial accounts.

If you receive an unsolicited email claiming to be from the IRS, forward this message to phishing@irs.gov. You may also report misuse of the IRS name, logo, or other IRS property to the Treasury Inspector General for Tax Administration (TIGTA) at 1-800-366-4484. You can forward suspicious emails to the Federal Trade Commission at spam@uce.gov or report them at www.ftc.gov/complaint. You can contact the FTC at www.ftc.gov/idtheft or 877-IDTHEFT (877-438-4338). If you have been the victim of identity theft, see www.IdentityTheft.gov and Pub. 5027.

Visit www.irs.gov/IdentityTheft to learn more about identity theft and how to reduce your risk.

Privacy Act Notice

Section 6109 of the Internal Revenue Code requires you to provide your correct TIN to persons (including federal agencies) who are required to file information returns with the IRS to report interest, dividends, or certain other income paid to you; mortgage interest you paid; the acquisition or abandonment of secured property; the cancellation of debt; or contributions you made to an IRA, Archer MSA, or HSA. The person collecting this form uses the information on the form to file information returns with the IRS, reporting the above information. Routine uses of this information include giving it to the Department of Justice for civil and criminal litigation and to cities, states, the District of Columbia, and U.S. commonwealths and possessions for use in administering their laws. The information also may be disclosed to other countries under a treaty, to federal and state agencies to enforce civil and criminal laws, or to federal law enforcement and intelligence agencies to combat terrorism. You must provide your TIN whether or not you are required to file a tax return. Under section 3406, payers must generally withhold a percentage of taxable interest, dividend, and certain other payments to a payee who does not give a TIN to the payer. Certain penalties may also apply for providing false or fraudulent information.

City of Naples FL

Invitation to Bid

18-029 RE-BID Decorative Street Signs

This project has potential for Federal Emergency Management Agency (FEMA) reimbursement and is subject to federal guidelines.

INDEX

		PAGE
COVER SHEET	REQUIRED	1
GENERAL CONDITIONS		2
GENERAL INSURANCE REQUIREMENTS		9
STATEMENT OF NO BID		10
REFERENCES	REQUIRED	11
SPECIAL CONDITIONS		12
SUBMISSION CHECKLIST	REQUIRED	13
IRS W-9 FORM	REQUIRED	14
SPECIFICATIONS		
PROJECT OVERVIEW		19
POST SPECIFICATIONS		
DECORATIVE COMPONENTS		
WELDING		
COATING AND COLOR		
INSTALLATION AND REMOVAL		
ACCEPTANCE		
PURCHASING REQUIREMENTS		
DETAILS AND MEASUREMENTS		
PRICE SCHEDULE	REQUIRED	28
Attachment A -	FEMA RELATED DOCUMENTS, CERTIFICATIONS AND REQUIREMENTS	

City of Naples FL

Invitation to Bid

18-029 RE-BID Decorative Street Signs

This project has potential for Federal Emergency Management Agency (FEMA) reimbursement and is subject to federal guidelines.

Project Overview

The purpose of this invitation to bid is to identify a potential responsive contractor to supply and install fully assembled decorative street and traffic signs. This project has potential for Federal Emergency Management Agency (FEMA) reimbursement and is subject to federal guidelines (refer to Attachment A).

1) Post Specifications

- a) Street posts shall have a 4" O.D. (Outside Diameter) and have a minimum thickness of 0.125". See Detail #6.
- b) The City wishes to have two different post lengths – 13', 15'. The 13' and 15' posts will be direct bury.
- c) Post length shall allow for 80" (see price schedule for all post lengths) from concrete foundation mounting to bottom of regulatory sign frame. The concrete foundation shall rise out of the ground and have an elevation of no less than 2.5" from the natural ground surface and no more than 3.5" from ground surface. The sign frame shall be 1" thick around the entire sign. Therefore, the sign, as mounted, shall have between 83.5" and 84.5" between natural ground surface and the bottom of the sign.
- d) Street posts shall be fluted and made of extruded aluminum.
- e) **Technical requirements must be verified by City with submittal of cut sheets and/or technical specifications. In the best interest of the City, the City reserves the right to consider alternative design options, dimensions, fabrication methods, assembly methods or any other variations as proposed by the manufacturer. Alternative design options must be signed and sealed by an engineer to meet 180 MPH wind speeds.**
- f) Horizontal clearances and offsets from edge of pavement, sidewalks, crosswalks, etc. shall meet criteria set forth by M.U.T.C.D. In accordance with Florida law, the Contractor shall call Florida Sunshine One to locate utilities prior to digging. Prior to installation, the Contractor shall identify the actual field location for each sign with the City's designated inspector. No sign shall be erected without the prior approval of the City inspector.

2) Decorative Components: Sign Frame, Finial, Base, Scroll, Street Name Flags

- a) **Sign Frame & Backing**: The sign frame shall be made from a single piece of cast aluminum and be bolted to an aluminum mounting bracket that is welded to the fluted aluminum post. An example of the sign frame backing is shown in Detail #7.
- b) **Finial**: Decorative finial caps shall be cast aluminum, be an "Acorn" design, and be made for and welded to the 4" fluted aluminum post. Please see Detail #8.
- c) **Base/Bell**: Decorative base shall be cast aluminum and welded to decorative post. Style

shall match the attached decorative base option selected and final approval shall be coordinated with the City.

- d) **Scroll:** Decorative scrolls shall be one-piece cast aluminum and welded to each decorative street name flag (frames) and decorative post. Style shall match the attached decorative scroll options. Please see Details #10, #11, and #12.
- e) **Street Name Flags (also called Frames and/or Paddle):** The sign flag shall be made from a single piece of cast aluminum and be welded to the fluted aluminum post and scroll. The custom street name flags (frames) shall be dimensioned as shown in Detail #9. To be included in this item are new street name signs. Two per flag.
- f) **Prior to any fabrication, shop drawings shall be delivered to the City for each component in #1 and #2 above. The City shall review each shop drawing and provide its approval or disapproval.**

3) Welding

- a) Contractor shall provide warranty on all welds. Duration of warranty shall be noted in the bid tabulation.
- a) With the exception of the sign frame and backing being bolted onto a mounting bracket, all decorative components shall be fully welded to the post and not mechanically fastened. Welds shall be continuous, without spacing. **Street name sign flag frames must also be bolted to the pole.**
- b) All welds to use Alcotech Alloy 4043 filling wire (or equivalent), ISO designation: Al5i5 ANSA/AWS A.510 (ER&R) AMS 4190. All welds to be properly filed, grounded, cleaned and prepped.

4) Coating and Color

Contractor shall provide warranty period for color coating and gloss. Coating shall be either aluminum powder coating or automotive urethane grade paint priming and finishes.

The powder coating shall adhere to the following standards:

- a) The coating shall be applied in the following stages:
 - i. Stage 1 – All products coated shall receive an alkaline cleaner application followed by a fresh water rinse.
 - ii. Stage 2 – Phosphoric Acid 4% solution treatment with a fluoride accelerant followed by a reverse osmosis water rinse at ambient temperature. The rinse shall be followed by a high-pressure air spray to remove all moisture from the product.
 - iii. Stage 3 – Non-chrome Polymer sealer application.
 - iv. Stage 4 – Oven drying.
 - v. Stage 5 – Electro-static application of polyester powder in a downdraft spray booth and applied by articulated robot arm sprayer and over sprayed by an application technician. Polyester powder overspray shall be recoverable and reusable.
 - vi. Stage 6 – Oven curing to harden powder finish and create final appearance and adhesion to the substrate. Curing shall be in a cooling tunnel to prepare for un-racking.

The paint and primer shall adhere to the following standards:

- i. Stage 1 – Aluminum to be washed, removed of all oils and dirt
- ii. Stage 2 – Aluminum to be primed with two-part self-etching primer
- iii. Stage 3 – Finish coat shall be two part-part automotive urethane and have no imperfections

b) The finish-coat of the entire assembly shall be high gloss black.

5) Installation and Removal

- a) All signs shall include installation in concrete foundations as specified in Detail #1. All signs will be located within the City limits and locations shall be approved by the City prior to installation.
- b) Concrete foundations shall be a minimum of sixteen inches (1.33-feet) in diameter for standard base and 36-inches (3 feet) deep regardless of base option, unless otherwise approved by the City. For any decorative base option the City selects, the concrete shall extend a minimum 3.5 inches outside the diameter of the selected base. Alternative size dimensions shall require the Contractor to provide engineering calculations showing the alternative base meets south Florida wind loading forces and break-a-way design standards. **This is to verify posts will be direct bury as specified.**
- c) **“The City shall have the option of directing the contractor of either bolting the decorative post to a prefabricated concrete base or extending the sign post into the foundation forms and pouring the concrete base around the post. Both options require the bottom of the concrete base to be raised between 2.5 and 3.5 inches from existing ground surface. This is intended to protect the sign post from weed- wackers and lawn mowers.”**
- d) The contractor may be required to remove existing damaged or old signs and relocate them to the city stock yard or as directed by City staff. It may also be a requirement to remove old bases and backfill with suitable soils. **Contractor will be responsible for removal and disposal of existing concrete base cores.**

6) Acceptance

- a) Contractor to provide a single unit for final approval prior to producing the remaining orders.

7) Purchasing Requirements

- a) Prices established by this bid shall be honored for a minimum of 24-months from the date the Agreement is executed by the City. The Contractor shall honor any order made by the City for any amount of decorative sign assemblies as allowed for by these specifications and at the rates set forth in the Bid Tabulation for a period of 12-months after the City's execution date of the Agreement. At the conclusion of the term of Agreement, the City and Contractor shall each have the option to extend the term of Agreement for two additional 12-month periods.

b) It is the City's desire to eventually replace all damaged or old decorative signs within the City limits; however, complete replacement will depend on budget and time. This initial purchase focuses on a specific level of effort within the City for Fiscal Year 2017-18. The agreement will be in effect for two years with up to three additional annual renewals, at prices to be negotiated for subsequent years.

c) The City also desires to have a stock supply on hand to be used as needed for emergency repair/replacement. The exact quantity and sign types shall be determined upon notice to proceed.

Detail #1: Sign Elevation with Decorative Components

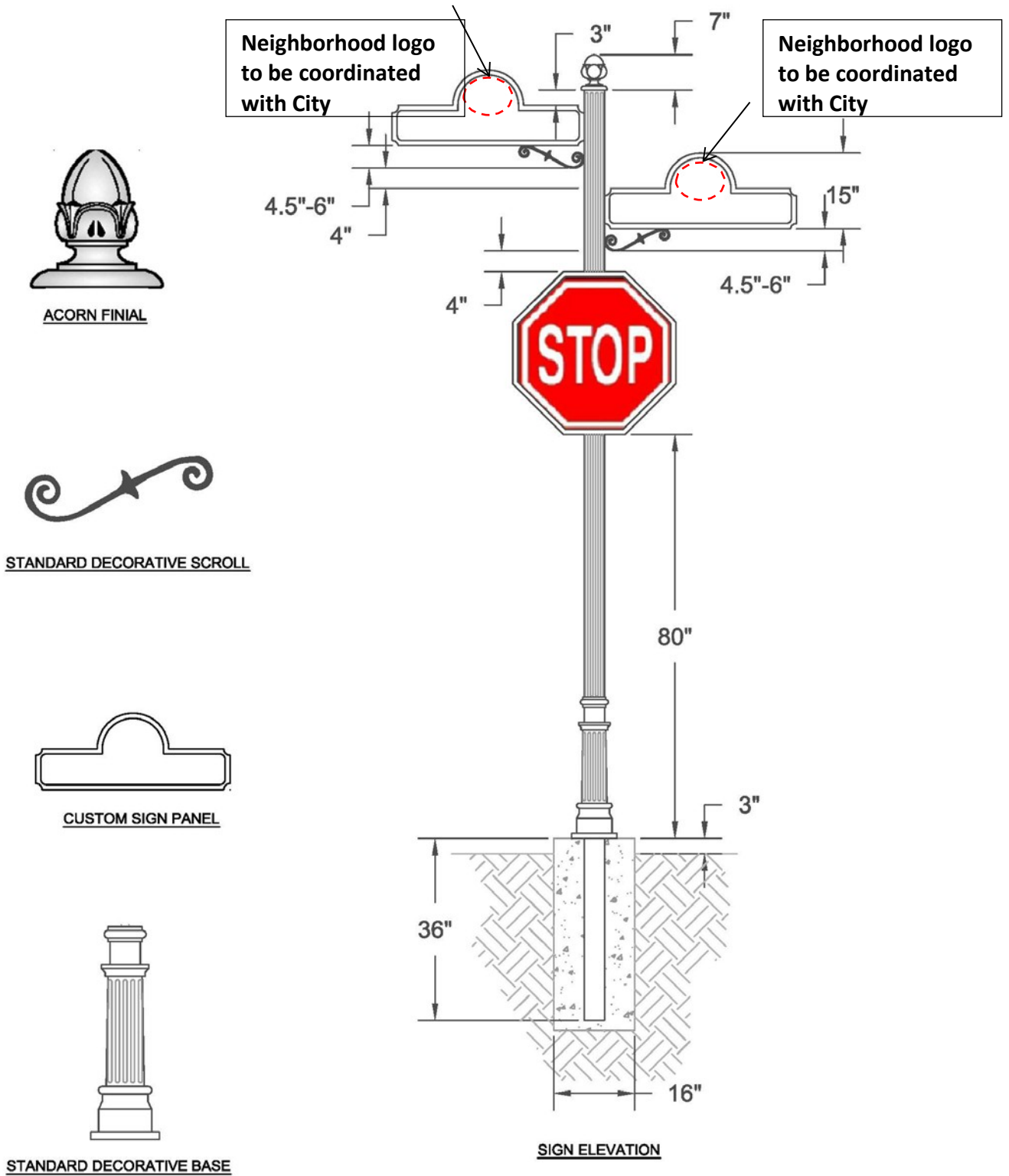

*** Street name paddles/flags are shown at 180 degrees to illustrate spacing along pole, actual angle to be 90 degrees.**

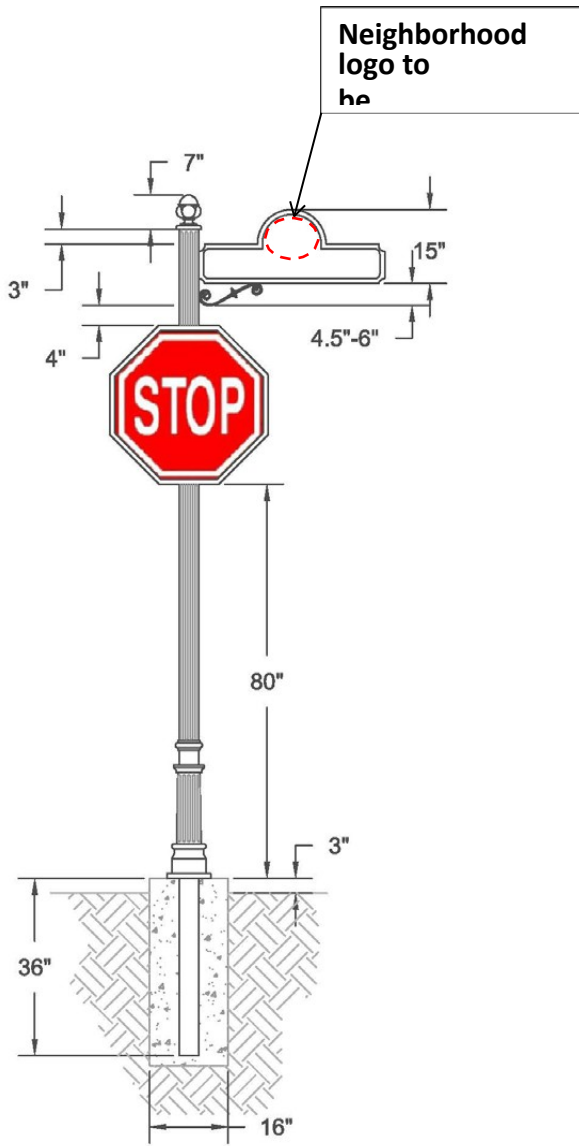

**Detail #2: Sign
Elevation w/**

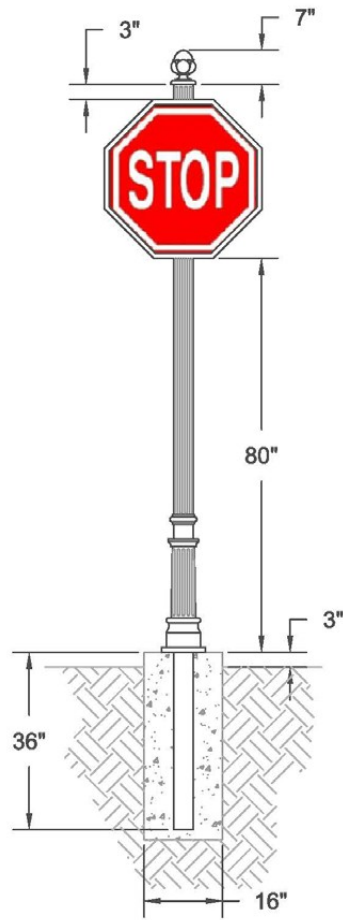

**Detail #3: Sign
Elevation**

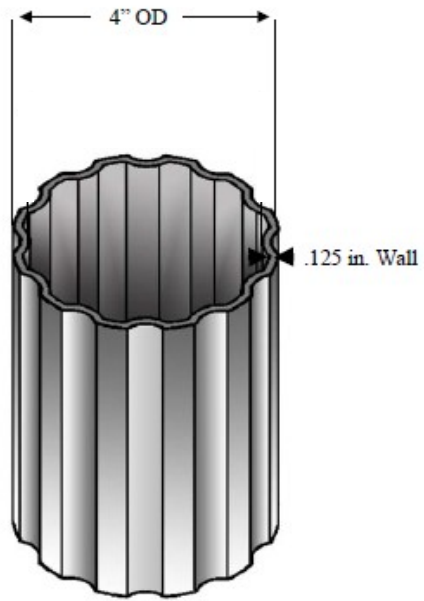

Detail #6: 4" OD Fluted Pole Extruded

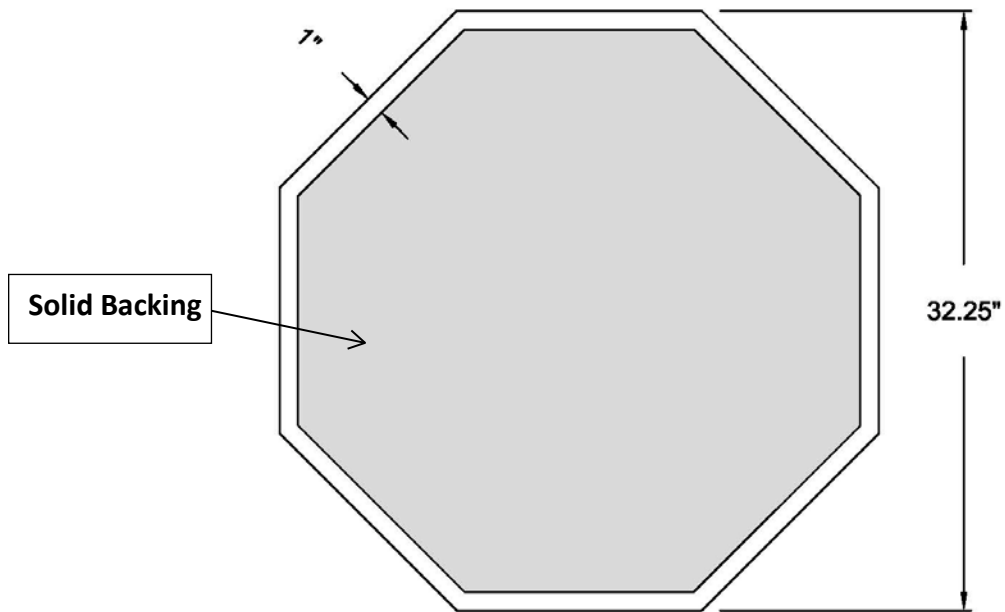

Detail #7: Trim for 30" Stop Sign Cast Aluminum Alloy

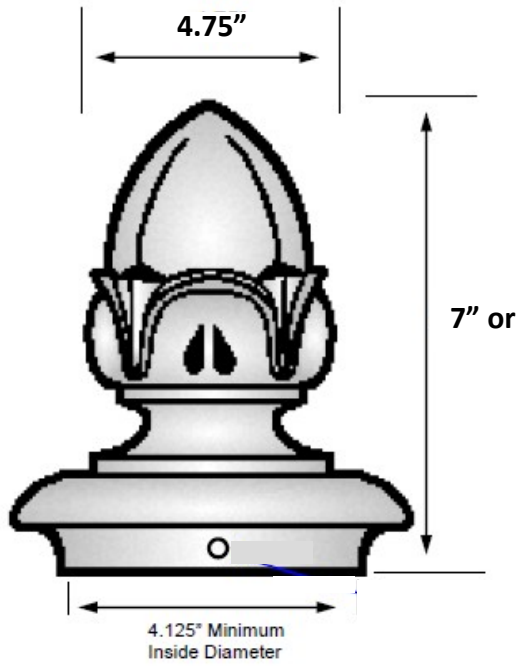

Detail #8: Acorn Finial for 4" OD Pole Cast Aluminum Alloy

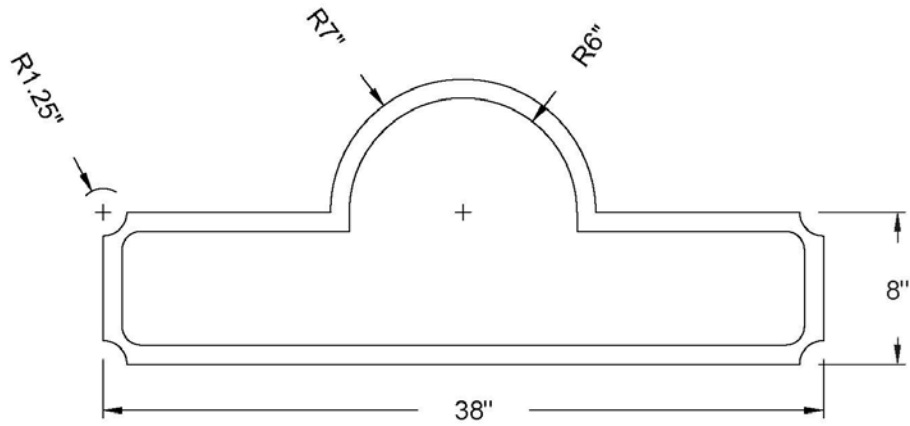

Detail #9: Sign Paddle
Dimensions

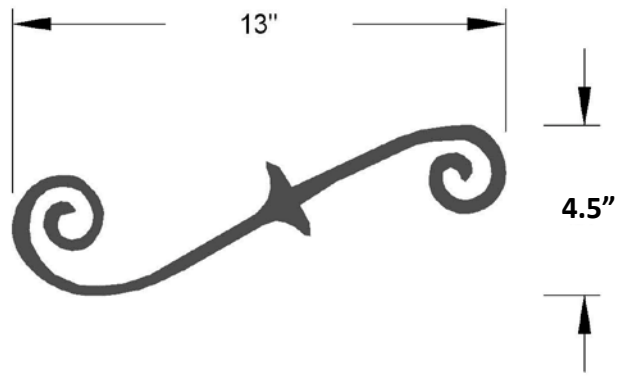

Detail #10: Standard Decorative Scroll Dimensions

PRICE SCHEDULE

This Sheet Must Be Completed and Returned With Bid

City of Naples - Price Schedule for ITB #18-029 Decorative Street Signs RE-BID

ITEM	DESCRIPTION OF MATERIALS AND SERVICE	UNITS	QUANTITY	UNIT PRICE	TOTAL
1	Supply & Install Fully Assembled Decorative STOP Sign with Two Street Name Flags (see detail #1)	EA	210	\$	\$
2	Supply & Install Fully Assembled Decorative STOP Sign with One Street Name Flag (see de tail #2)	EA	80	\$	\$
3	Supply & Install Fully Assembled Decorative STOP Sign - No Street Name Flags (see detail #3)	EA	30	\$	\$
4	Supply Only Fully Assembled Decorative STOP Sign with Two Street Name Flags	EA	5	\$	\$
5 Part 1	Supply Only Fully Assembled Decorative STOP Sign with One Street Name Flag	EA	5	\$	\$
5 Part 2	Supply Only Fully Assembled Decorative STOP Sign - No Street Name Flags	EA	5	\$	\$
6	Supply & Install Fully Assembled Decorative Speed Limit Sign	EA	85	\$	\$
7	Supply Only Fully: Assembled Decorative Speed Limit Sign	EA	2	\$	\$
8	Supply & Install Fully Assembled YIELD Sign	EA	25	\$	\$
9	Supply Only Fully Assembled YIELD Sign	EA	2	\$	\$
10	Supply Split aluminum base for 4" round pole, size 36.25" Tall x 4" ID, color satin black, hardware included	EA	5	\$	\$
11	Supply 1" SQ aluminum tube frame and solid aluminum .080 backer for 30" x 30" stop signs, including 2 welded 4" back clamp	EA	3	\$	\$
12	Supply 1" SQ aluminum tube frame and solid aluminum .080 backer for 30" x 24" speed limit signs, including 2 welded 4" back clamp	EA	3	\$	\$
13	Supply 1" SQ aluminum tube frame and solid aluminum .080 backer for 30" x 30" yield sign, including 2 welded 4" back clamp	EA	3	\$	\$
14	Supply 1" SQ aluminum tube frame and solid aluminum .080 backer for 12" x 18" street sign, including 2 welded 4" back clamp	EA	3	\$	\$
15	Supply 4" round acorn finial, include set screw. Color satin black	EA	5	\$	\$
TOTAL					\$

WARRANTIES	DURATION (Years)
1 Welds, bolts, rivets, sign adhesive.	
2 Color and gloss	
3 Materials, foundations and workmanship	

Company Name: _____

EIN: _____

Email: _____

Name and Title of individual completing this schedule:

(Printed Name) **(Title)**

X _____

(Signature) **(Date)**

Part 1 SUPPLEMENTAL CONDITIONS AND CONTRACT PROVISIONS

**SUPPLEMENTAL CONDITIONS AND CONTRACT PROVISIONS FOR
NON-FEDERAL ENTITY CONTRACTS UNDER FEDERAL AWARDS**

1.0 FEDERAL FUNDING:

When property or services are procured using funds derived from a Federal grant or agreement whether direct to the County or “pass-through” from another entity, the County is required to and will follow the Federal procurement standards in the “Uniform Administrative Requirements, Cost Principles, and Audit Requirements for Federal Awards”, 2 C.F.R. Sections 200.213 and 200.317 through 200.326.

Contract Cost and Price: For every procurement in excess of \$100,000, including contract modifications or change orders greater than \$100,000, the County shall perform a cost or price analysis in connection with every procurement subject to Federal procurement guidelines, which shall include an independent estimate of cost prior to issuing bids or proposals. For proposals where price is not considered in the award, profit shall be negotiated as a separate element of the price. In determining whether profit is fair and reasonable, the County shall consider the complexity of work, the risk to be borne by the contractor, the contractor’s investment, the amount of subcontracting necessary, the quality of the contractor’s record and past performance, and industry profit rates for the surrounding geographical area. “Cost Plus Percentage” methods for determining profit may not be used.

2.0 EQUAL EMPLOYMENT OPPORTUNITY:

During the performance of this contract, the contractor agrees as follows:

- a. The contractor will not discriminate against any employee or applicant for employment because of race, color, religion, sex, sexual orientation, gender identity, or national origin. The contractor will take affirmative action to ensure that applicants are employed, and that employees are treated during employment, without regard to their race, color, religion, sex, sexual orientation, gender identity, or national origin. Such action shall include, but not be limited to the following: Employment, upgrading, demotion, or transfer, recruitment or recruitment advertising; layoff or termination; rates of pay or other forms of compensation; and selection for training, including apprenticeship. The contractor agrees to post in conspicuous places, available to employees and applicants for employment, notices to be provided by the contracting officer setting forth the provisions of this nondiscrimination clause.
- b. The contractor will, in all solicitations or advertisements for employees placed by or on behalf of the contractor, state that all qualified applicants will receive consideration for employment without regard to race, color, religion, sex, sexual orientation, gender identity, or national origin.
- c. The contractor will not discharge or in any other manner discriminate against any employee or applicant for employment because such employee or applicant has inquired about, discussed, or disclosed the compensation of the employee or applicant or another employee or applicant. This provision shall not apply to instances in which an employee who has access to the compensation information of other employees or applicants as a part of such employee's essential job functions discloses the compensation of such other employees or applicants to individuals who do not otherwise have access to such information, unless such disclosure is in response to a formal complaint or charge, in furtherance of an investigation, proceeding, hearing, or action, including an investigation conducted by the employer, or is consistent with the contractor's legal duty to furnish information.

- d. The contractor will send to each labor union or representative of workers with which it has a collective bargaining agreement or other contract or understanding, a notice to be provided by the agency contracting officer, advising the labor union or workers' representative of the contractor's commitments under section 202 of Executive Order 11246 of September 24, 1965, and shall post copies of the notice in conspicuous places available to employees and applicants for employment.
- e. The contractor will comply with all provisions of Executive Order 11246 of September 24, 1965, and of the rules, regulations, and relevant orders of the Secretary of Labor.
- f. The contractor will furnish all information and reports required by Executive Order 11246 of September 24, 1965, and by the rules, regulations, and orders of the Secretary of Labor, or pursuant thereto, and will permit access to his books, records, and accounts by the contracting agency and the Secretary of Labor for purposes of investigation to ascertain compliance with such rules, regulations, and orders.
- g. In the event of the contractor's non-compliance with the nondiscrimination clauses of this contract or with any of such rules, regulations, or orders, this contract may be canceled, terminated or suspended in whole or in part and the contractor may be declared ineligible for further Government contracts in accordance with procedures authorized in Executive Order 11246 of September 24, 1965, and such other sanctions may be imposed and remedies invoked as provided in Executive Order 11246 of September 24, 1965, or by rule, regulation, or order of the Secretary of Labor, or as otherwise provided by law.
- h. The contractor will include the provisions of paragraphs (a) through (h) in every subcontract or purchase order unless exempted by rules, regulations, or orders of the Secretary of Labor issued pursuant to section 204 of Executive Order 11246 of September 24, 1965, so that such provisions will be binding upon each subcontractor or vendor. The contractor will take such action with respect to any subcontract or purchase order as may be directed by the Secretary of Labor as a means of enforcing such provisions including sanctions for noncompliance: Provided, however, that in the event the contractor becomes involved in, or is threatened with, litigation with a subcontractor or vendor as a result of such direction, the contractor may request the United States to enter into such litigation to protect the interests of the United States.

3.0 MAINTENANCE OF RECORDS:

- a. The Contractor will keep and maintain adequate records and supporting documentation applicable to all of the services, work, information, expense, costs, invoices and materials provided and performed pursuant to the requirements of this agreement. Said records and documentation will be retained by the Contractor for a minimum of five (5) years from the date of termination of this agreement, or for such period is required by law.
- b. Contractor shall provide, when requested, access by the County, Federal granting agency, the Comptroller General of the United States, or any of their duly authorized representatives to any books, documents, papers, and records of the contractor which are directly pertinent to this contract for the purpose of making audit, examination, excerpts, and transcriptions.
- c. Contractor agrees to permit any of the foregoing parties to reproduce by any means whatsoever or to copy excerpts and transcriptions as reasonably needed.
- d. Contractor agrees to provide the FEMA Administrator or his authorized representatives' access to construction or other work sites pertaining to the work being completed under the contract.

- e. Contractor shall retain all records associated with this solicitation and any agreements that are created in response to the solicitation for a period of no less than five (5) years after final payments and all other pending matters are closed.
- f. The County and its authorized agents shall, with reasonable prior notice, have the right to audit, inspect and copy all such records and documentation as often as the County deems necessary during the period of this agreement, and during the period as set forth in the paragraphs above; provided, however, such activities shall be conducted only during normal business hours of the Contractor and at the expense of the County.

4.0 PURPOSE:

The requirements under this solicitation may be funded in whole or in part with federal funds and as such, is subject to federal requirements including, but no limited to, those set forth in 2 C.F.R. Part 200, Appendix II and as otherwise may be listed below.

5.0 SUBCONTRACTS

The selected firm must require compliance with all federal requirements listed below of all subcontractors performing work the value of which is in excess of \$10,000, by including these federal requirements in all contracts with subcontractors.

6.0 CONFLICT OF INTEREST:

No employee, officer, or agent may participate in the selection, award, or administration of a contract supported by a Federal award if he or she has a real or apparent conflict of interest. Such a conflict of interest would arise when the employee, officers, or agent, any member of his or her immediate family, his or her partner, or an organization which employs or is about to employ any of the parties indicated herein, has a financial or other interest in or a tangible personal benefit from a firm considered for a contract. The officers, employees, and agents of the non-Federal entity must neither solicit nor accept gratuities, favors, or anything of monetary value from contractors or parties to subcontracts.

7.0 APPLICABLE FEDERAL REQUIREMENTS – 2 C.F.R Part 200, APPENDIX II:

Remedies. Unless otherwise provided by the Contract, all claims, counter-claims, disputes and other matters in question between the County and the Contractor arising out of or relating to the Service Provider Agreement between the parties, or the breach of it, that cannot be resolved by and between the parties after conferring in good faith, will be decided by a court of competent jurisdiction pursuant to Florida law. If such dispute is in state court, venue shall be in the Twentieth Judicial Circuit Court in and for Lee County, Florida. If in federal court, venue shall be in the U.S. District Court for the Middle District of Florida, Ft. Myers Division.

8.0 CLEAN AIR ACT & FEDERAL WATER POLLUTION CONTROL ACT

The successful firm awarded a contract in excess of \$100,000 agrees to comply with all applicable standards, orders or regulations issued pursuant to the Clean Air Act and the Federal Water Pollution Control Act as amended. Violations shall be reported to the Federal awarding agency and the Regional Office of the Environmental Protection Agency (EPA).

9.0 CONTRACT WORK HOURS & SAFETY STANDARDS (40 U.S.C. 3701-3708):.

Where applicable, all contracts awarded by the non-Federal entity in excess of \$100,000 that involve the employment of mechanics or laborers must include a provision for compliance with 40 U.S.C. 3702 and 3704, as supplemented by Department of Labor regulations (29 C.F.R. Part 5). Under 40 U.S.C. 3702 of the Act, each contractor must be required to compute the wages of every mechanic and laborer on the basis of a standard work week of 40 hours. Work in excess of the standard work week is permissible provided that the worker is compensated at a rate of not less than one and a half times the basic rate of pay for all hours worked in excess of 40 hours in the work week. These requirements do not apply to the purchases of supplies or materials or articles ordinarily available on the open market, or contracts for transportation or transmission of intelligence.

U.S.C. 3704 are applicable to construction work and provide that no laborer or mechanic must be required to work in surroundings or under working conditions which are unsanitary, hazardous or dangerous. These requirements do not apply to the purchases of supplies or materials or articles ordinarily available on the open market, or contracts for transportation or transmission of intelligence.

10.0 SUSPENSION AND DEBARMENT

This contract is a covered transaction for purposes of 2 C.F.R. pt. 180 and 2 C.F.R. pt. 3000. As such the contractor is required to verify that none of the contractor, its principals (defined at 2 C.F.R. § 180.995), or its affiliates (defined at 2 C.F.R. § 180.905) are excluded (defined at 2 C.F.R. § 180.940) or disqualified (defined at 2 C.F.R. § 180.935).

The contractor must comply with 2 C.F.R. pt. 180, subpart C and 2 C.F.R. pt. 3000, subpart C and must include a requirement to comply with these regulations in any lower tier covered transaction it enters into.

This certification is a **material representation** of fact relied upon by the awarded contractor. If it is later determined that the contractor did not comply with 2 C.F.R. pt.180, subpart C and 2 C.F.R. pt. 3000, subpart C, in addition to remedies available to Lee County, the Federal Government may pursue available remedies, including but not limited to suspension and/or debarment.

11.0 BYRD ANTI-LOBBYING AMENDMENT

Contractors who apply or bid for an award of \$100,000 or more shall file the required certification. Each tier certifies to the tier above that it will not and has not used Federal appropriated funds to pay any person or organization for influencing or attempting to influence an officer or employee of any agency, a member of Congress, officer or employee of Congress, or an employee of a member of Congress in connection with obtaining any Federal contract, grant, or any other award covered by 31 U.S.C. § 1352. Each tier shall also disclose any lobbying with nonfederal funds that takes place in connection with obtaining any Federal award. Such disclosures are forwarded from tier to tier up to the recipient.

12.0 RECOVERED MATERIALS

Contractor must comply with section 6002 of the Solid Waste Disposal Act, as amended by the Resource Conservation and Recovery Act. The requirements of Section 6002 include procuring only items designated in guidelines of the Environmental Protection Agency (EPA) at 40 CFR part 247 that contain the highest percentage of recovered materials practicable, consistent with maintaining a satisfactory level of competition, where the purchase price of the item exceeds \$10,000 or the value of the quantity acquired during the preceding fiscal year exceeded \$10,000; procuring solid waste management services in a manner that maximizes energy and resource recovery; and establishing an affirmative procurement program for procurement of recovered

materials identified in the EPA guidelines. [78 FR 78608, Dec. 26, 2013, as amended at 79 FR 75885, Dec. 19, 2014]

13.0 DHS SEAL, LOGO, AND FLAGS

The Contractor shall not use the DHS seal(s), logos, crests, or reproductions of flags or likenesses of DHS agency officials without specific FEMA pre-approval.

14.0 COMPLIANCE WITH FEDERAL LAW, REGULATIONS, and EXECUTIVE ORDERS

This is an acknowledgment that FEMA financial assistance will be used only to fund the services provided under this solicitation. The Contractor will comply with all applicable federal law, regulations, executive orders, FEMA policies, procedures, and directives.

15.0 NO OBLIGATION BY THE FEDERAL GOVERNMENT

The Federal Government is not a party to this solicitation and is not subject to any obligations or liabilities to the non-Federal entity, Contractor, or any other party pertaining to any matter resulting from the Solicitation.

16.0 FRAUD and FALSE OR FRAUDULENT OR RELATED ACTS

The Contractor acknowledges that 31 U.S.C. Chapter 38 (Administrative Remedies for False Claims and Statements) applies to the Contractors actions pertaining to this solicitation.

17.0 OTHER REMEDIES AND RIGHTS:

Pursuing any of the above remedies will not keep the County from pursuing any other rights or remedies, which may be otherwise available under law or in equity. If the County waives any right or remedy in this Agreement or fails to insist on strict performance by the Contractor, it will not affect, extend or waive any other right or remedy of the County, or affect the later exercise of the same right or remedy by the County for any other default by the Contractor.

18.0 EMPLOYMENT ELIGIBILITY VERIFICATION SYSTEM (E-VERIFY):

Statutes and Executive Orders require employers to abide by the Immigration laws of the United States and to employ only individuals who are eligible to work in the United States. The Employment Eligibility Verification System (E-Verify) operated by the U.S. Department of Homeland Security (DHS) in partnership with the Social Security Administration (SSA) to provides an internet-based means of verifying employment eligibility of workers in the united States; it is not a substitute for any other employment eligibility verification requirements.

Vendors/bidders are required to enroll in the E-Verify program and provide acceptable evidence of their enrollment, at the time of the submission of the vendor's/bidder's proposal.

Acceptable evidence consists of a copy of the properly completed E-Verify Company Profile page or a copy of the fully executed E-Verify Memorandum of Understanding for the company. **Vendors are also required to provide the Lee County Purchasing Department an executed affidavit certifying they shall comply with the E-Verify Program. The affidavit is attached to the solicitation documents.**

If the Bidder/Vendor does not comply with providing both the acceptable E-Verify evidence and the executed affidavit the bidder's / vendor's proposal may be deemed non-responsive.

Subcontractor requirement: Vendors shall require all subcontracted vendors to flow down the requirement to use E-Verify to subcontractors.

It shall be the vendor's responsibility to familiarize themselves with all rules and regulations governing this program.

For additional information regarding the Employment Eligibility Verification System (E-Verify) program visit the following website: <http://www.dhs.gov/E-Verify>.

19.0 TERMINATION FOR CAUSE AND/OR CONVENIENCE:

The County, by written notice to the Contractor, may terminate this Agreement with or without cause, in whole or in part, when the County determines in its sole discretion that it is in the County's best interest to do so. In the event of termination the Contractor will not incur any new obligations for the terminated portion of the Agreement after the Contractor has received notification of termination.

If the Agreement is terminated before performance is completed, the Contractor shall be paid only for that work satisfactorily performed for which costs can be substantiated. Such payment, however, may not exceed an amount that is the same percentage of the Agreement price as the amount of work satisfactorily completed is a percentage of the total work called for by this Agreement. All work in progress shall become the property of the County and shall be turned over promptly by the Contractor.

20.0 ENERGY POLICY AND CONSERVATION ACT

Contractor must follow any mandatory standards and policies relating to energy efficiency which are contained in the state energy conservation plan issued in compliance with the Energy Policy and Conservation Act (42 U.S.C. 6201).

21.0 REMEDIES

In the event the Contractor fails to satisfactorily perform or has failed to adhere to the terms and conditions under this Agreement, the County may, upon fifteen (15) calendar days written notice to the Contractor and upon the Contractor's failure to cure within those fifteen (15) calendar days, exercise any one or more of the following remedies, either concurrently or consecutively:

- Withhold or suspend payment of all or any part of a request for payment.
- Require that the Contractor refund to the County any monies used for ineligible purposes under the laws, rules and regulations governing the use of these funds.

Exercise any corrective or remedial actions, to include but not be limited to:

- Requesting additional information from the Contractor to determine the reasons for or the extent of non-compliance or lack of performance;
- Issuing a written warning to advise that more serious measures may be taken if the situation is not corrected;
- Advising the Contractor to suspend, discontinue or refrain from incurring costs for any activities in question; or
- Requiring the Contractor to reimburse the County for the amount of costs incurred for any items determined to be ineligible.

22.0 SMALL AND MINORITY BUSINESS, WOMEN’S BUSINESS ENTERPRISES, AND LABOR SURPLUS AREA FIRMS:

- (1) Place qualified small and minority businesses and women’s business enterprises on solicitation lists.
- (2) Assuring that small and minority businesses, and women’s business enterprises are solicited whenever they are potential sources.
- (3) Using the services and assistance, as appropriate, of such organizations as the Small Business Administration and the Minority Business Development Agency of the Department of Commerce.
- (4) Dividing total requirements, when economically feasible, into smaller tasks or quantities to permit maximum participation by small and minority businesses, and women’s business enterprises.
- (5) Establishing delivery schedules, where the requirement permits, which encourage participation by small and minority businesses, and women’s business enterprises.
- (6) Requiring the prime contractor, if subcontracts are to be let, to take the five previous affirmative steps.

23.0 COPELAND "ANTI-KICKBACK" ACT:

22.403–2 Copeland Act - The Copeland (Anti-Kickback) Act (18 U.S.C. 874 and 40 U.S.C. 3145) makes it unlawful to induce, by force, intimidation, threat of procuring dismissal from employment, or otherwise, any person employed in the construction or repair of public buildings or public works, financed in whole or in part by the United States, to give up any part the United States, to give up any part of the compensation to which that person is entitled under a contract of employment. The Copeland Act also requires each contractor and subcontractor to furnish weekly a statement of compliance with respect to the wages paid each employee during the preceding week.

The Contractor shall comply with the requirements of: 29 CFR Part 3 - CONTRACTORS AND SUBCONTRACTORS ON PUBLIC BUILDING OR PUBLIC WORK FINANCED IN WHOLE OR IN PART BY LOANS OR GRANTS FROM THE UNITED STATES.

24.0 REGULATIONS GOVERNING CONTRACTORS AND SUBCONTRACTORS

In general, the Secretary of Labor shall prescribe reasonable regulations for contractors and subcontractors engaged in constructing, carrying out, completing, or repairing public buildings, public works, or buildings or works that at least partly are financed by a loan or grant from the Federal Government. The regulations shall include a provision that each contractor and subcontractor each week must furnish a statement on the wages paid each employee during the prior week.

25.0 DAVIS-BACON ACT:

The Davis-Bacon Act (40 U.S.C. 3141et seq.) provides that contracts in excess of \$2,000 to which the United States or the District of Columbia is a party for construction, alteration, or repair (including painting and decorating) of public buildings or public works within the United States.

No laborer or mechanic employed directly upon the site of the work shall receive less than the prevailing wage rates as determined by the Secretary of Labor. (Ref. 48CFR Ch. 1 (10-1-16 Edition, Section 52.222-6 Construction Wage Rate Requirements.

Prevailing wage rates shall be pursuant with the United States Department of Labor Wage and Hour Division and in accordance with the year the services are provided.

26.0 All contracts awarded by a recipient shall contain the following provisions as applicable.

Notice: Awarded Bidder(s)/Vendor(s) and all associated contractor(s) are also considered recipients and therefore, the following provisions must be included in all contract provisions; inclusive those of the subcontractor(s) when and where applicable.

End of Supplemental Conditions

Part 2 CERTIFICATION REGARDING LOBBYING

CERTIFICATION REGARDING LOBBYING

The undersigned certifies, to the best of his or her knowledge and belief, that:

- (1) No Federal appropriated funds have been paid or will be paid, by or on behalf of the undersigned, to any person for influencing or attempting to influence an officer or employee of any agency, a Member of Congress, an officer or employee of Congress, or an employee of a Member of Congress in connection with the awarding of any Federal grant, the making of any Federal loan, the entering into of any cooperative agreement, and the extension, continuation, renewal, amendment or modification of any Federal contract, grant, loan, or cooperative agreement.
- (2) If any funds other than Federal appropriated funds have been paid or will be paid to any person for influencing or attempting to influence an officer or employee of any agency, a Member of Congress, an officer or employee of Congress, or an employee of a Member of Congress in connection with this Federal contract, grant, loan, or cooperative agreement, the undersigned shall complete and submit Standard Form-LLL, "Disclosure of Lobbying Activities," in accordance with its instructions.
- (3) The undersigned shall require that the language of this certification be included in the award documents of all sub-awards at all tiers (including subcontracts, sub-grants, and contracts under grants, loans, and cooperative agreements) and that all sub-recipients shall certify and disclose accordingly.

This certification is a material representation of fact upon which reliance was placed when this transaction was made or entered into. Submission of this certification is a prerequisite for making or entering into this transaction imposed by section 1352, title 31, United States Code. Any person who fails to file the required certification shall be subject to a civil penalty of not less than \$10,000 and not more than \$100,000 for each such failure.

The Contractor, _____, certifies or affirms the truthfulness and accuracy of each statement of its certification and disclosure, if any. In addition, the Contractor understands and agrees that the provisions of 31 U.S.C. § 3801 *et seq.*, apply to this certification and disclosure, if any.

Signature of Contractor's Authorized Official

Name & Title of Contractors Authorized Official

Date

DISCLOSURE OF LOBBYING ACTIVITIES

Complete this form to disclose lobbying activities pursuant to 31 U.S.C.1352

Approved by OMB
4040-0013

1. * Type of Federal Action: <input type="checkbox"/> a. contract <input checked="" type="checkbox"/> b. grant <input type="checkbox"/> c. cooperative agreement <input type="checkbox"/> d. loan <input type="checkbox"/> e. loan guarantee <input type="checkbox"/> f. loan insurance	2. * Status of Federal Action: <input type="checkbox"/> a. bid/offer/application <input checked="" type="checkbox"/> b. initial award <input type="checkbox"/> c. post-award	3. * Report Type: <input checked="" type="checkbox"/> a. initial filing <input type="checkbox"/> b. material change
4. Name and Address of Reporting Entity: <input checked="" type="checkbox"/> Prime <input type="checkbox"/> SubAwardee * Name <input style="width: 100%;" type="text"/> * Street 1 <input style="width: 45%;" type="text"/> Street 2 <input style="width: 45%;" type="text"/> * City <input style="width: 30%;" type="text"/> State <input style="width: 30%;" type="text"/> Zip <input style="width: 15%;" type="text"/> Congressional District, if known: <input style="width: 40%;" type="text"/>		
5. If Reporting Entity in No.4 is Subawardee, Enter Name and Address of Prime: <div style="height: 100px;"></div>		
6. * Federal Department/Agency: <input style="width: 100%;" type="text"/>	7. * Federal Program Name/Description: <input style="width: 100%;" type="text"/> CFDA Number, if applicable: <input style="width: 80%;" type="text"/>	
8. Federal Action Number, if known: <input style="width: 100%;" type="text"/>	9. Award Amount, if known: \$ <input style="width: 80%;" type="text"/>	
10. a. Name and Address of Lobbying Registrant: Prefix <input style="width: 10%;" type="text"/> * First Name <input style="width: 30%;" type="text"/> Middle Name <input style="width: 30%;" type="text"/> * Last Name <input style="width: 40%;" type="text"/> Suffix <input style="width: 10%;" type="text"/> * Street 1 <input style="width: 45%;" type="text"/> Street 2 <input style="width: 45%;" type="text"/> * City <input style="width: 30%;" type="text"/> State <input style="width: 30%;" type="text"/> Zip <input style="width: 15%;" type="text"/>		
b. Individual Performing Services (including address if different from No. 10a) Prefix <input style="width: 10%;" type="text"/> * First Name <input style="width: 30%;" type="text"/> Middle Name <input style="width: 30%;" type="text"/> * Last Name <input style="width: 40%;" type="text"/> Suffix <input style="width: 10%;" type="text"/> * Street 1 <input style="width: 45%;" type="text"/> Street 2 <input style="width: 45%;" type="text"/> * City <input style="width: 30%;" type="text"/> State <input style="width: 30%;" type="text"/> Zip <input style="width: 15%;" type="text"/>		
11. Information requested through this form is authorized by title 31 U.S.C. section 1352. This disclosure of lobbying activities is a material representation of fact upon which reliance was placed by the tier above when the transaction was made or entered into. This disclosure is required pursuant to 31 U.S.C. 1352. This information will be reported to the Congress semi-annually and will be available for public inspection. Any person who fails to file the required disclosure shall be subject to a civil penalty of not less than \$10,000 and not more than \$100,000 for each such failure. * Signature: <input style="width: 100%;" type="text"/> * Name: Prefix <input style="width: 10%;" type="text"/> * First Name <input style="width: 30%;" type="text"/> Middle Name <input style="width: 30%;" type="text"/> * Last Name <input style="width: 40%;" type="text"/> Suffix <input style="width: 10%;" type="text"/> Title: <input style="width: 30%;" type="text"/> Telephone No.: <input style="width: 30%;" type="text"/> Date: <input style="width: 30%;" type="text"/>		
Federal Use Only:		Authorized for Local Reproduction Standard Form - LLL (Rev. 7-97)

Part 4 E-Verify Affidavit

Attachment: Immigration Law Affidavit Certification

This Affidavit is required and should be signed by an authorized principal of the firm, notarized and submitted with formal Invitations to Bid (ITB's) and Request for Proposals (RFP) submittals. Further, Vendors / Bidders are required to enroll in the E-Verify program, and provide acceptable evidence of their enrollment, at the time of the submission of the vendor's/bidder's proposal. Acceptable evidence consists of a copy of the properly completed E-Verify Company Profile page or a copy of the fully executed E-Verify Memorandum of Understanding for the company. **Failure to include this Affidavit and acceptable evidence of enrollment in the E-Verify program, may deem the Vendor / Bidder's proposal as non-responsive.**

Lee County will not intentionally award County contracts to any vendor who knowingly employs unauthorized alien workers, constituting a violation of the employment provision contained in 8 U.S.C. Section 1324 a(e) Section 274A(e) of the Immigration and Nationality Act ("INA").

Lee County may consider the employment by any vendor of unauthorized aliens a violation of Section 274A (e) of the INA. Such Violation by the recipient of the Employment Provisions contained in Section 274A (e) of the INA shall be grounds for unilateral termination of the contract by Lee County.

Vendor attests that they are fully compliant with all applicable immigration laws (specifically to the 1986 Immigration Act and subsequent Amendment(s)) and agrees to comply with the provisions of the Memorandum of Understanding with E-Verify and to provide proof of enrollment in The Employment Eligibility Verification System (E-Verify), operated by the Department of Homeland Security in partnership with the Social Security Administration at the time of submission of the Vendor's / Bidder's proposal.

Company Name _____

Print Name _____ Title _____

Signature _____ Date _____

State of _____

County of _____

The foregoing instrument was signed and acknowledged before me this _____ day of _____, 20____, by

_____ who has produced _____ as identification.
(Print or Type Name) (Type of Identification and Number)

Notary Public Signature

Printed Name of Notary Public

Notary Commission Number/Expiration

The signee of these Affidavit guarantees, as evidenced by the sworn affidavit required herein, the truth and accuracy of this affidavit to interrogatories hereinafter made.

Part 5 PART 200—UNIFORM ADMINISTRATIVE REQUIREMENTS,**ELECTRONIC CODE OF FEDERAL REGULATIONS****e-CFR data is current as of April 24, 2015**

Title 2 → Subtitle A → Chapter II → Part 200

Title 2: Grants and Agreements

PART 200—UNIFORM ADMINISTRATIVE REQUIREMENTS, COST PRINCIPLES, AND AUDIT REQUIREMENTS FOR FEDERAL AWARDS**Contents****Subpart A—Acronyms and Definitions**

ACRONYMS

- §200.0 Acronyms.
- §200.1 Definitions.
- §200.2 Acquisition cost.
- §200.3 Advance payment.
- §200.4 Allocation.
- §200.5 Audit finding.
- §200.6 Auditee.
- §200.7 Auditor.
- §200.8 Budget.
- §200.9 Central service cost allocation plan.
- §200.10 Catalog of Federal Domestic Assistance (CFDA) number.
- §200.11 CFDA program title.
- §200.12 Capital assets.
- §200.13 Capital expenditures.
- §200.14 Claim.
- §200.15 Class of Federal awards.
- §200.16 Closeout.
- §200.17 Cluster of programs.
- §200.18 Cognizant agency for audit.
- §200.19 Cognizant agency for indirect costs.
- §200.20 Computing devices.
- §200.21 Compliance supplement.
- §200.22 Contract.
- §200.23 Contractor.
- §200.24 Cooperative agreement.
- §200.25 Cooperative audit resolution.
- §200.26 Corrective action.
- §200.27 Cost allocation plan.
- §200.28 Cost objective.
- §200.29 Cost sharing or matching.
- §200.30 Cross-cutting audit finding.
- §200.31 Disallowed costs.
- §200.32 [Reserved]
- §200.33 Equipment.
- §200.34 Expenditures.
- §200.35 Federal agency.
- §200.36 Federal Audit Clearinghouse (FAC).
- §200.37 Federal awarding agency.
- §200.38 Federal award.
- §200.39 Federal award date.
- §200.40 Federal financial assistance.
- §200.41 Federal interest.
- §200.42 Federal program.
- §200.43 Federal share.
- §200.44 Final cost objective.
- §200.45 Fixed amount awards.
- §200.46 Foreign public entity.
- §200.47 Foreign organization.
- §200.48 General purpose equipment.
- §200.49 Generally Accepted Accounting Principles (GAAP).
- §200.50 Generally Accepted Government Auditing Standards (GAGAS).
- §200.51 Grant agreement.
- §200.52 Hospital.
- §200.53 Improper payment.
- §200.54 Indian tribe (or "federally recognized Indian tribe").
- §200.55 Institutions of Higher Education (IHEs).
- §200.56 Indirect (facilities & administrative (F&A)) costs.

- §200.57 Indirect cost rate proposal.
- §200.58 Information technology systems.
- §200.59 Intangible property.
- §200.60 Intermediate cost objective.
- §200.61 Internal controls.
- §200.62 Internal control over compliance requirements for Federal awards.
- §200.63 Loan.
- §200.64 Local government.
- §200.65 Major program.
- §200.66 Management decision.
- §200.67 Micro-purchase.
- §200.68 Modified Total Direct Cost (MTDC).
- §200.69 Non-Federal entity.
- §200.70 Nonprofit organization.
- §200.71 Obligations.
- §200.72 Office of Management and Budget (OMB).
- §200.73 Oversight agency for audit.
- §200.74 Pass-through entity.
- §200.75 Participant support costs.
- §200.76 Performance goal.
- §200.77 Period of performance.
- §200.78 Personal property.
- §200.79 Personally Identifiable Information (PII).
- §200.80 Program income.
- §200.81 Property.
- §200.82 Protected Personally Identifiable Information (Protected PII).
- §200.83 Project cost.
- §200.84 Questioned cost.
- §200.85 Real property.
- §200.86 Recipient.
- §200.87 Research and Development (R&D).
- §200.88 Simplified acquisition threshold.
- §200.89 Special purpose equipment.
- §200.90 State.
- §200.91 Student Financial Aid (SFA).
- §200.92 Subaward.
- §200.93 Subrecipient.
- §200.94 Supplies.
- §200.95 Termination.
- §200.96 Third-party in-kind contributions.
- §200.97 Unliquidated obligations.
- §200.98 Unobligated balance.
- §200.99 Voluntary committed cost sharing.

Subpart B—General Provisions

- §200.100 Purpose.
- §200.101 Applicability.
- §200.102 Exceptions.
- §200.103 Authorities.
- §200.104 Supersession.
- §200.105 Effect on other issuances.
- §200.106 Agency implementation.
- §200.107 OMB responsibilities.
- §200.108 Inquiries.
- §200.109 Review date.
- §200.110 Effective/applicability date.
- §200.111 English language.
- §200.112 Conflict of interest.
- §200.113 Mandatory disclosures.

Subpart C—Pre-Federal Award Requirements and Contents of Federal Awards

- §200.200 Purpose.
- §200.201 Use of grant agreements (including fixed amount awards), cooperative agreements, and contracts.
- §200.202 Requirement to provide public notice of Federal financial assistance programs.
- §200.203 Notices of funding opportunities.
- §200.204 Federal awarding agency review of merit of proposals.
- §200.205 Federal awarding agency review of risk posed by applicants.
- §200.206 Standard application requirements.
- §200.207 Specific conditions.
- §200.208 Certifications and representations.
- §200.209 Pre-award costs.
- §200.210 Information contained in a Federal award.
- §200.211 Public access to Federal award information.
- §200.212 Suspension and debarment.

Subpart D—Post Federal Award Requirements

STANDARDS FOR FINANCIAL AND PROGRAM MANAGEMENT

- §200.300 Statutory and national policy requirements.
- §200.301 Performance measurement.
- §200.302 Financial management.
- §200.303 Internal controls.
- §200.304 Bonds.
- §200.305 Payment.
- §200.306 Cost sharing or matching.
- §200.307 Program income.
- §200.308 Revision of budget and program plans.
- §200.309 Period of performance.

PROPERTY STANDARDS

- §200.310 Insurance coverage.
- §200.311 Real property.
- §200.312 Federally-owned and exempt property.
- §200.313 Equipment.
- §200.314 Supplies.
- §200.315 Intangible property.
- §200.316 Property trust relationship.

PROCUREMENT STANDARDS

- §200.317 Procurements by states.
- §200.318 General procurement standards.
- §200.319 Competition.
- §200.320 Methods of procurement to be followed.
- §200.321 Contracting with small and minority businesses, women's business enterprises, and labor surplus area firms.
- §200.322 Procurement of recovered materials.
- §200.323 Contract cost and price.
- §200.324 Federal awarding agency or pass-through entity review.
- §200.325 Bonding requirements.
- §200.326 Contract provisions.

PERFORMANCE AND FINANCIAL MONITORING AND REPORTING

- §200.327 Financial reporting.
- 200.328 Monitoring and reporting program performance.
- §200.329 Reporting on real property.

SUBRECIPIENT MONITORING AND MANAGEMENT

- §200.330 Subrecipient and contractor determinations.
- §200.331 Requirements for pass-through entities.
- §200.332 Fixed amount subawards.

RECORD RETENTION AND ACCESS

- §200.333 Retention requirements for records.
- §200.334 Requests for transfer of records.
- §200.335 Methods for collection, transmission and storage of information.
- §200.336 Access to records.
- §200.337 Restrictions on public access to records.

REMEDIES FOR NONCOMPLIANCE

- §200.338 Remedies for noncompliance.
- §200.339 Termination.
- §200.340 Notification of termination requirement.
- §200.341 Opportunities to object, hearings and appeals.
- §200.342 Effects of suspension and termination.

CLOSEOUT

- §200.343 Closeout.

POST-CLOSEOUT ADJUSTMENTS AND CONTINUING RESPONSIBILITIES

- §200.344 Post-closeout adjustments and continuing responsibilities.

COLLECTION OF AMOUNTS DUE

- §200.345 Collection of amounts due.

Subpart E—Cost Principles

GENERAL PROVISIONS

- §200.400 Policy guide.
- §200.401 Application.

BASIC CONSIDERATIONS

- §200.402 Composition of costs.
- §200.403 Factors affecting allowability of costs.
- §200.404 Reasonable costs.
- §200.405 Allocable costs.
- §200.406 Applicable credits.
- §200.407 Prior written approval (prior approval).
- §200.408 Limitation on allowance of costs.
- §200.409 Special considerations.
- §200.410 Collection of unallowable costs.
- §200.411 Adjustment of previously negotiated indirect (F&A) cost rates containing unallowable costs.

DIRECT AND INDIRECT (F&A) COSTS

- §200.412 Classification of costs.
- §200.413 Direct costs.
- §200.414 Indirect (F&A) costs.
- §200.415 Required certifications.

SPECIAL CONSIDERATIONS FOR STATES, LOCAL GOVERNMENTS AND INDIAN TRIBES

- §200.416 Cost allocation plans and indirect cost proposals.
- §200.417 Interagency service.

SPECIAL CONSIDERATIONS FOR INSTITUTIONS OF HIGHER EDUCATION

- §200.418 Costs incurred by states and local governments.
- §200.419 Cost accounting standards and disclosure statement.

GENERAL PROVISIONS FOR SELECTED ITEMS OF COST

- §200.420 Considerations for selected items of cost.
- §200.421 Advertising and public relations.
- §200.422 Advisory councils.
- §200.423 Alcoholic beverages.
- §200.424 Alumni/ae activities.
- §200.425 Audit services.
- §200.426 Bad debts.
- §200.427 Bonding costs.
- §200.428 Collections of improper payments.
- §200.429 Commencement and convocation costs.
- §200.430 Compensation—personal services.
- §200.431 Compensation—fringe benefits.
- §200.432 Conferences.
- §200.433 Contingency provisions.
- §200.434 Contributions and donations.
- §200.435 Defense and prosecution of criminal and civil proceedings, claims, appeals and patent infringements.
- §200.436 Depreciation.
- §200.437 Employee health and welfare costs.
- §200.438 Entertainment costs.
- §200.439 Equipment and other capital expenditures.
- §200.440 Exchange rates.
- §200.441 Fines, penalties, damages and other settlements.
- §200.442 Fund raising and investment management costs.
- §200.443 Gains and losses on disposition of depreciable assets.
- §200.444 General costs of government.
- §200.445 Goods or services for personal use.
- §200.446 Idle facilities and idle capacity.
- §200.447 Insurance and indemnification.
- §200.448 Intellectual property.
- §200.449 Interest.
- §200.450 Lobbying.
- §200.451 Losses on other awards or contracts.
- §200.452 Maintenance and repair costs.
- §200.453 Materials and supplies costs, including costs of computing devices.
- §200.454 Memberships, subscriptions, and professional activity costs.
- §200.455 Organization costs.
- §200.456 Participant support costs.
- §200.457 Plant and security costs.
- §200.458 Pre-award costs.
- §200.459 Professional service costs.
- §200.460 Proposal costs.
- §200.461 Publication and printing costs.
- §200.462 Rearrangement and reconversion costs.
- §200.463 Recruiting costs.
- §200.464 Relocation costs of employees.
- §200.465 Rental costs of real property and equipment.
- §200.466 Scholarships and student aid costs.
- §200.467 Selling and marketing costs.
- §200.468 Specialized service facilities.
- §200.469 Student activity costs.
- §200.470 Taxes (including Value Added Tax).
- §200.471 Termination costs.

- §200.472 Training and education costs.
- §200.473 Transportation costs.
- §200.474 Travel costs.
- §200.475 Trustees.

Subpart F—Audit Requirements

GENERAL

- §200.500 Purpose.

AUDITS

- §200.501 Audit requirements.
- §200.502 Basis for determining Federal awards expended.
- §200.503 Relation to other audit requirements.
- §200.504 Frequency of audits.
- §200.505 Sanctions.
- §200.506 Audit costs.
- §200.507 Program-specific audits.

AUDITEES

- §200.508 Auditee responsibilities.
- §200.509 Auditor selection.
- §200.510 Financial statements.
- §200.511 Audit findings follow-up.
- §200.512 Report submission.

FEDERAL AGENCIES

- §200.513 Responsibilities.

AUDITORS

- §200.514 Scope of audit.
- §200.515 Audit reporting.
- §200.516 Audit findings.
- §200.517 Audit documentation.
- §200.518 Major program determination.
- §200.519 Criteria for Federal program risk.
- §200.520 Criteria for a low-risk auditee.

MANAGEMENT DECISIONS

- §200.521 Management decision.
- Appendix I to Part 200—Full Text of Notice of Funding Opportunity
- Appendix II to Part 200—Contract Provisions for Non-Federal Entity Contracts Under Federal Awards
- Appendix III to Part 200—Indirect (F&A) Costs Identification and Assignment, and Rate Determination for Institutions of Higher Education (IHEs)
- Appendix IV to Part 200—Indirect (F&A) Costs Identification and Assignment, and Rate Determination for Nonprofit Organizations
- Appendix V to Part 200—State/Local Governmentwide Central Service Cost Allocation Plans
- Appendix VI to Part 200—Public Assistance Cost Allocation Plans
- Appendix VII to Part 200—States and Local Government and Indian Tribe Indirect Cost Proposals
- Appendix VIII to Part 200—Nonprofit Organizations Exempted From Subpart E—Cost Principles of Part 200
- Appendix IX to Part 200—Hospital Cost Principles
- Appendix X to Part 200—Data Collection Form (Form SF-SAC)
- Appendix XI to Part 200—Compliance Supplement

AUTHORITY: 31 U.S.C. 503

SOURCE: 78 FR 78608, Dec. 26, 2013, unless otherwise noted.

[↑ Back to Top](#)

Subpart A—Acronyms and Definitions

[↑ Back to Top](#)

ACRONYMS

[↑ Back to Top](#)

§200.0 Acronyms.

ACRONYM	TERM
---------	------

CAS	Cost Accounting Standards
CFDA	Catalog of Federal Domestic Assistance
CFR	Code of Federal Regulations
CMIA	Cash Management Improvement Act

COG Councils Of Governments
COSO Committee of Sponsoring Organizations of the Treadway Commission
EPA Environmental Protection Agency
ERISA Employee Retirement Income Security Act of 1974 (29 U.S.C. 1301-1461)
EUI Energy Usage Index
F&A Facilities and Administration
FAC Federal Audit Clearinghouse
FAIN Federal Award Identification Number
FAPIS Federal Awardee Performance and Integrity Information System
FAR Federal Acquisition Regulation
FFATA Federal Funding Accountability and Transparency Act of 2006 or Transparency Act—Public Law 109-282, as amended by section 6202 (a) of Public Law 110-252 (31 U.S.C. 6101)
FICA Federal Insurance Contributions Act
FOIA Freedom of Information Act
FR Federal Register
FTE Full-time equivalent
GAAP Generally Accepted Accounting Principles
GAGAS Generally Accepted Government Auditing Standards
GAO Government Accountability Office
GOCO Government owned, contractor operated
GSA General Services Administration
IBS Institutional Base Salary
IHE Institutions of Higher Education
IRC Internal Revenue Code
ISDEAA Indian Self-Determination and Education and Assistance Act
MTC Modified Total Cost
MTDC Modified Total Direct Cost
OMB Office of Management and Budget
PII Personally Identifiable Information
PMS Payment Management System
PRHP Post-retirement Health Plans
PTE Pass-through Entity
REUI Relative Energy Usage Index
SAM System for Award Management
SFA Student Financial Aid
SNAP Supplemental Nutrition Assistance Program
SPOC Single Point of Contact
TANF Temporary Assistance for Needy Families
TFM Treasury Financial Manual
U.S.C. United States Code
VAT Value Added Tax
[78 FR 78608, Dec. 26, 2013, as amended at 79 FR 75880, Dec. 19, 2014]

[↑ Back to Top](#)

§200.1 Definitions.

These are the definitions for terms used in this part. Different definitions may be found in Federal statutes or regulations that apply more specifically to particular programs or activities. These definitions could be supplemented by additional instructional information provided in governmentwide standard information collections.

[↑ Back to Top](#)

§200.2 Acquisition cost.

Acquisition cost means the cost of the asset including the cost to ready the asset for its intended use. Acquisition cost for equipment, for example, means the net invoice price of the equipment, including the cost of any modifications, attachments, accessories, or auxiliary apparatus necessary to make it usable for the purpose for which it is acquired. Acquisition costs for software includes those development costs capitalized in accordance with generally accepted accounting principles (GAAP). Ancillary charges, such as taxes, duty, protective in transit insurance, freight, and installation may be included in or excluded from the acquisition cost in accordance with the non-Federal entity's regular accounting practices.

[↑ Back to Top](#)

§200.3 Advance payment.

Advance payment means a payment that a Federal awarding agency or pass-through entity makes by any appropriate payment mechanism, including a predetermined payment schedule, before the non-Federal entity disburses the funds for program purposes.

[↑ Back to Top](#)

§200.4 Allocation.

Allocation means the process of assigning a cost, or a group of costs, to one or more cost objective(s), in reasonable proportion to the benefit provided or other equitable relationship. The process may entail assigning a cost(s) directly to a final cost objective or through one or more intermediate cost objectives.

[↑ Back to Top](#)

§200.5 Audit finding.

Audit finding means deficiencies which the auditor is required by §200.516 Audit findings, paragraph (a) to report in the schedule of findings and questioned costs.

[↑ Back to Top](#)

§200.6 Auditee.

Auditee means any non-Federal entity that expends Federal awards which must be audited under Subpart F—Audit Requirements of this part.

[↑ Back to Top](#)

§200.7 Auditor.

Auditor means an auditor who is a public accountant or a Federal, state, local government, or Indian tribe audit organization, which meets the general standards specified for external auditors in generally accepted government auditing standards (GAGAS). The term auditor does not include internal auditors of nonprofit organizations.

[79 FR 75880, Dec. 19, 2014]

[↑ Back to Top](#)

§200.8 Budget.

Budget means the financial plan for the project or program that the Federal awarding agency or pass-through entity approves during the Federal award process or in subsequent amendments to the Federal award. It may include the Federal and non-Federal share or only the Federal share, as determined by the Federal awarding agency or pass-through entity.

[↑ Back to Top](#)

§200.9 Central service cost allocation plan.

Central service cost allocation plan means the documentation identifying, accumulating, and allocating or developing billing rates based on the allowable costs of services provided by a state, local government, or Indian tribe on a centralized basis to its departments and agencies. The costs of these services may be allocated or billed to users.

[↑ Back to Top](#)

§200.10 Catalog of Federal Domestic Assistance (CFDA) number.

CFDA number means the number assigned to a Federal program in the CFDA.

[↑ Back to Top](#)

§200.11 CFDA program title.

CFDA program title means the title of the program under which the Federal award was funded in the CFDA.

[↑ Back to Top](#)

§200.12 Capital assets.

Capital assets means tangible or intangible assets used in operations having a useful life of more than one year which are capitalized in accordance with GAAP. Capital assets include:

(a) Land, buildings (facilities), equipment, and intellectual property (including software) whether acquired by purchase, construction, manufacture, lease-purchase, exchange, or through capital leases; and

(b) Additions, improvements, modifications, replacements, rearrangements, reinstallations, renovations or alterations to capital assets that materially increase their value or useful life (not ordinary repairs and maintenance).

[↑ Back to Top](#)

§200.13 Capital expenditures.

Capital expenditures means expenditures to acquire capital assets or expenditures to make additions, improvements, modifications, replacements, rearrangements, reinstallations, renovations, or alterations to capital assets that materially increase their value or useful life.

[↑ Back to Top](#)

§200.14 Claim.

Claim means, depending on the context, either:

(a) A written demand or written assertion by one of the parties to a Federal award seeking as a matter of right:

(1) The payment of money in a sum certain;

(2) The adjustment or interpretation of the terms and conditions of the Federal award; or

(3) Other relief arising under or relating to a Federal award.

(b) A request for payment that is not in dispute when submitted.

[↑ Back to Top](#)

§200.15 Class of Federal awards.

Class of Federal awards means a group of Federal awards either awarded under a specific program or group of programs or to a specific type of non-Federal entity or group of non-Federal entities to which specific provisions or exceptions may apply.

[↑ Back to Top](#)

§200.16 Closeout.

Closeout means the process by which the Federal awarding agency or pass-through entity determines that all applicable administrative actions and all required work of the Federal award have been completed and takes actions as described in §200.343 Closeout.

[↑ Back to Top](#)

§200.17 Cluster of programs.

Cluster of programs means a grouping of closely related programs that share common compliance requirements. The types of clusters of programs are research and development (R&D), student financial aid (SFA), and other clusters. "Other clusters" are as defined by OMB in the compliance supplement or as designated by a state for Federal awards the state provides to its subrecipients that meet the definition of a cluster of programs. When designating an "other cluster," a state must identify the Federal awards included in the cluster and advise the subrecipients of compliance requirements applicable to the cluster, consistent with §200.331 Requirements for pass-through entities, paragraph (a). A cluster of programs must be considered as one program for determining major programs, as described in §200.518 Major program determination, and, with the exception of R&D as described in §200.501 Audit requirements, paragraph (c), whether a program-specific audit may be elected.

[↑ Back to Top](#)

§200.18 Cognizant agency for audit.

Cognizant agency for audit means the Federal agency designated to carry out the responsibilities described in §200.513 Responsibilities, paragraph (a). The cognizant agency for audit is not necessarily the same as the cognizant agency for indirect costs. A list of cognizant agencies for audit may be found at the FAC Web site.

[↑ Back to Top](#)

§200.19 Cognizant agency for indirect costs.

Cognizant agency for indirect costs means the Federal agency responsible for reviewing, negotiating, and approving cost allocation plans or indirect cost proposals developed under this part on behalf of all Federal agencies. The cognizant agency for indirect cost is not necessarily the same as the cognizant agency for audit. For assignments of cognizant agencies see the following:

(a) For IHEs: Appendix III to Part 200—Indirect (F&A) Costs Identification and Assignment, and Rate Determination for Institutions of Higher Education (IHEs), paragraph C.11.

(b) For nonprofit organizations: Appendix IV to Part 200—Indirect (F&A) Costs Identification and Assignment, and Rate Determination for Nonprofit Organizations, paragraph C.12.

(c) For state and local governments: Appendix V to Part 200—State/Local Governmentwide Central Service Cost Allocation Plans, paragraph F.1.

(d) For Indian tribes: Appendix VII to Part 200—States and Local Government and Indian Tribe Indirect Cost Proposal, paragraph D.1.

[78 FR 78608, Dec. 26, 2013, as amended at 79 FR 75880, Dec. 19, 2014]

[↑ Back to Top](#)

§200.20 Computing devices.

Computing devices means machines used to acquire, store, analyze, process, and publish data and other information electronically, including accessories (or “peripherals”) for printing, transmitting and receiving, or storing electronic information. See also §§200.94 Supplies and 200.58 Information technology systems.

[↑ Back to Top](#)

§200.21 Compliance supplement.

Compliance supplement means Appendix XI to Part 200—Compliance Supplement (previously known as the Circular A-133 Compliance Supplement).

[↑ Back to Top](#)

§200.22 Contract.

Contract means a legal instrument by which a non-Federal entity purchases property or services needed to carry out the project or program under a Federal award. The term as used in this part does not include a legal instrument, even if the non-Federal entity considers it a contract, when the substance of the transaction meets the definition of a Federal award or subaward (see §200.92 Subaward).

[↑ Back to Top](#)

§200.23 Contractor.

Contractor means an entity that receives a contract as defined in §200.22 Contract.

[↑ Back to Top](#)

§200.24 Cooperative agreement.

Cooperative agreement means a legal instrument of financial assistance between a Federal awarding agency or pass-through entity and a non-Federal entity that, consistent with 31 U.S.C. 6302-6305:

(a) Is used to enter into a relationship the principal purpose of which is to transfer anything of value from the Federal awarding agency or pass-through entity to the non-Federal entity to carry out a public purpose authorized by a law of the United States (see 31 U.S.C. 6101(3)); and not to acquire property or services for the Federal Government or pass-through entity's direct benefit or use;

(b) Is distinguished from a grant in that it provides for substantial involvement between the Federal awarding agency or pass-through entity and the non-Federal entity in carrying out the activity contemplated by the Federal award.

(c) The term does not include:

(1) A cooperative research and development agreement as defined in 15 U.S.C. 3710a; or

(2) An agreement that provides only:

(i) Direct United States Government cash assistance to an individual;

(ii) A subsidy;

(iii) A loan;

(iv) A loan guarantee; or

(v) Insurance.

[↑ Back to Top](#)

§200.25 Cooperative audit resolution.

Cooperative audit resolution means the use of audit follow-up techniques which promote prompt corrective action by improving communication, fostering collaboration, promoting trust, and developing an understanding between the Federal agency and the non-Federal entity. This approach is based upon:

(a) A strong commitment by Federal agency and non-Federal entity leadership to program integrity;

(b) Federal agencies strengthening partnerships and working cooperatively with non-Federal entities and their auditors; and non-Federal entities and their auditors working cooperatively with Federal agencies;

(c) A focus on current conditions and corrective action going forward;

(d) Federal agencies offering appropriate relief for past noncompliance when audits show prompt corrective action has occurred; and

(e) Federal agency leadership sending a clear message that continued failure to correct conditions identified by audits which are likely to cause improper payments, fraud, waste, or abuse is unacceptable and will result in sanctions.

[↑ Back to Top](#)

§200.26 Corrective action.

Corrective action means action taken by the auditee that:

- (a) Corrects identified deficiencies;
- (b) Produces recommended improvements; or
- (c) Demonstrates that audit findings are either invalid or do not warrant auditee action.

[↑ Back to Top](#)

§200.27 Cost allocation plan.

Cost allocation plan means central service cost allocation plan or public assistance cost allocation plan.

[↑ Back to Top](#)

§200.28 Cost objective.

Cost objective means a program, function, activity, award, organizational subdivision, contract, or work unit for which cost data are desired and for which provision is made to accumulate and measure the cost of processes, products, jobs, capital projects, etc. A cost objective may be a major function of the non-Federal entity, a particular service or project, a Federal award, or an indirect (Facilities & Administrative (F&A)) cost activity, as described in Subpart E—Cost Principles of this Part. See also §§200.44 Final cost objective and 200.60 Intermediate cost objective.

[↑ Back to Top](#)

§200.29 Cost sharing or matching.

Cost sharing or matching means the portion of project costs not paid by Federal funds (unless otherwise authorized by Federal statute). See also §200.306 Cost sharing or matching.

[↑ Back to Top](#)

§200.30 Cross-cutting audit finding.

Cross-cutting audit finding means an audit finding where the same underlying condition or issue affects Federal awards of more than one Federal awarding agency or pass-through entity.

[↑ Back to Top](#)

§200.31 Disallowed costs.

Disallowed costs means those charges to a Federal award that the Federal awarding agency or pass-through entity determines to be unallowable, in accordance with the applicable Federal statutes, regulations, or the terms and conditions of the Federal award.

[↑ Back to Top](#)

§200.32 [Reserved]

[↑ Back to Top](#)

§200.33 Equipment.

Equipment means tangible personal property (including information technology systems) having a useful life of more than one year and a per-unit acquisition cost which equals or exceeds the lesser of the capitalization level established by the non-Federal entity for financial statement purposes, or \$5,000. See also §§200.12 Capital assets, 200.20 Computing devices, 200.48 General purpose equipment, 200.58 Information technology systems, 200.89 Special purpose equipment, and 200.94 Supplies.

[↑ Back to Top](#)

§200.34 Expenditures.

Expenditures means charges made by a non-Federal entity to a project or program for which a Federal award was received.

- (a) The charges may be reported on a cash or accrual basis, as long as the methodology is disclosed and is consistently applied.
- (b) For reports prepared on a cash basis, expenditures are the sum of:
 - (1) Cash disbursements for direct charges for property and services;
 - (2) The amount of indirect expense charged;
 - (3) The value of third-party in-kind contributions applied; and
 - (4) The amount of cash advance payments and payments made to subrecipients.
- (c) For reports prepared on an accrual basis, expenditures are the sum of:

- (1) Cash disbursements for direct charges for property and services;
- (2) The amount of indirect expense incurred;
- (3) The value of third-party in-kind contributions applied; and
- (4) The net increase or decrease in the amounts owed by the non-Federal entity for:
 - (i) Goods and other property received;
 - (ii) Services performed by employees, contractors, subrecipients, and other payees; and
 - (iii) Programs for which no current services or performance are required such as annuities, insurance claims, or other benefit payments.

[↑ Back to Top](#)

§200.35 Federal agency.

Federal agency means an "agency" as defined at 5 U.S.C. 551(1) and further clarified by 5 U.S.C. 552(f).

[↑ Back to Top](#)

§200.36 Federal Audit Clearinghouse (FAC).

FAC means the clearinghouse designated by OMB as the repository of record where non-Federal entities are required to transmit the reporting packages required by Subpart F—Audit Requirements of this part. The mailing address of the FAC is Federal Audit Clearinghouse, Bureau of the Census, 1201 E. 10th Street, Jeffersonville, IN 47132 and the web address is: <http://harvester.census.gov/sac/>. Any future updates to the location of the FAC may be found at the OMB Web site.

[↑ Back to Top](#)

§200.37 Federal awarding agency.

Federal awarding agency means the Federal agency that provides a Federal award directly to a non-Federal entity.

[↑ Back to Top](#)

§200.38 Federal award.

Federal award has the meaning, depending on the context, in either paragraph (a) or (b) of this section:

(a)(1) The Federal financial assistance that a non-Federal entity receives directly from a Federal awarding agency or indirectly from a pass-through entity, as described in §200.101 Applicability; or

(2) The cost-reimbursement contract under the Federal Acquisition Regulations that a non-Federal entity receives directly from a Federal awarding agency or indirectly from a pass-through entity, as described in §200.101 Applicability.

(b) The instrument setting forth the terms and conditions. The instrument is the grant agreement, cooperative agreement, other agreement for assistance covered in paragraph (b) of §200.40 Federal financial assistance, or the cost-reimbursement contract awarded under the Federal Acquisition Regulations.

(c) Federal award does not include other contracts that a Federal agency uses to buy goods or services from a contractor or a contract to operate Federal Government owned, contractor operated facilities (GOCOs).

(d) See also definitions of Federal financial assistance, grant agreement, and cooperative agreement.

[↑ Back to Top](#)

§200.39 Federal award date.

Federal award date means the date when the Federal award is signed by the authorized official of the Federal awarding agency.

[↑ Back to Top](#)

§200.40 Federal financial assistance.

(a) For grants and cooperative agreements, *Federal financial assistance* means assistance that non-Federal entities receive or administer in the form of:

- (1) Grants;
- (2) Cooperative agreements;
- (3) Non-cash contributions or donations of property (including donated surplus property);
- (4) Direct appropriations;
- (5) Food commodities; and
- (6) Other financial assistance (except assistance listed in paragraph (b) of this section).

(b) For Subpart F—Audit Requirements of this part, *Federal financial assistance* also includes assistance that non-Federal entities receive or administer in the form of:

- (1) Loans;
- (2) Loan Guarantees;
- (3) Interest subsidies; and
- (4) Insurance.

(c) *Federal financial assistance* does not include amounts received as reimbursement for services rendered to individuals as described in §200.502 Basis for determining Federal awards *expended*, paragraph (h) and (i) of this part.

[↑ Back to Top](#)

§200.41 Federal interest.

Federal interest means, for purposes of §200.329 Reporting on real property or when used in connection with the acquisition or improvement of real property, equipment, or supplies under a Federal award, the dollar amount that is the product of the:

- (a) Federal share of total project costs; and
- (b) Current fair market value of the property, improvements, or both, to the extent the costs of acquiring or improving the property were included as project costs.

[↑ Back to Top](#)

§200.42 Federal program.

Federal program means:

- (a) All Federal awards which are assigned a single number in the CFDA.
- (b) When no CFDA number is assigned, all Federal awards to non-Federal entities from the same agency made for the same purpose must be combined and considered one program.
- (c) Notwithstanding paragraphs (a) and (b) of this definition, a cluster of programs. The types of clusters of programs are:
 - (1) Research and development (R&D);
 - (2) Student financial aid (SFA); and
 - (3) "Other clusters," as described in the definition of Cluster of Programs.

[78 FR 78608, Dec. 26, 2013, as amended at 79 FR 75880, Dec. 19, 2014]

[↑ Back to Top](#)

§200.43 Federal share.

Federal share means the portion of the total project costs that are paid by Federal funds.

[↑ Back to Top](#)

§200.44 Final cost objective.

Final cost objective means a cost objective which has allocated to it both direct and indirect costs and, in the non-Federal entity's accumulation system, is one of the final accumulation points, such as a particular award, internal project, or other direct activity of a non-Federal entity. See also §§200.28 Cost objective and 200.60 Intermediate cost objective.

[↑ Back to Top](#)

§200.45 Fixed amount awards.

Fixed amount awards means a type of grant agreement under which the Federal awarding agency or pass-through entity provides a specific level of support without regard to actual costs incurred under the Federal award. This type of Federal award reduces some of the administrative burden and record-keeping requirements for both the non-Federal entity and Federal awarding agency or pass-through entity. Accountability is based primarily on performance and results. See §§200.201 Use of grant agreements (including fixed amount awards), cooperative agreements, and contracts, paragraph (b) and 200.332 Fixed amount subawards.

[↑ Back to Top](#)

§200.46 Foreign public entity.

Foreign public entity means:

- (a) A foreign government or foreign governmental entity;
- (b) A public international organization, which is an organization entitled to enjoy privileges, exemptions, and immunities as an international organization under the International Organizations Immunities Act (22 U.S.C. 288-288f);
- (c) An entity owned (in whole or in part) or controlled by a foreign government; or
- (d) Any other entity consisting wholly or partially of one or more foreign governments or foreign governmental entities.

[↑ Back to Top](#)

§200.47 Foreign organization.

Foreign organization means an entity that is:

(a) A public or private organization located in a country other than the United States and its territories that is subject to the laws of the country in which it is located, irrespective of the citizenship of project staff or place of performance;

(b) A private nongovernmental organization located in a country other than the United States that solicits and receives cash contributions from the general public;

(c) A charitable organization located in a country other than the United States that is nonprofit and tax exempt under the laws of its country of domicile and operation, and is not a university, college, accredited degree-granting institution of education, private foundation, hospital, organization engaged exclusively in research or scientific activities, church, synagogue, mosque or other similar entities organized primarily for religious purposes; or

(d) An organization located in a country other than the United States not recognized as a Foreign Public Entity.

[78 FR 78608, Dec. 26, 2013, as amended at 79 FR 75880, Dec. 19, 2014]

[↑ Back to Top](#)

§200.48 General purpose equipment.

General purpose equipment means equipment which is not limited to research, medical, scientific or other technical activities. Examples include office equipment and furnishings, modular offices, telephone networks, information technology equipment and systems, air conditioning equipment, reproduction and printing equipment, and motor vehicles. See also Equipment and Special Purpose Equipment.

[↑ Back to Top](#)

§200.49 Generally Accepted Accounting Principles (GAAP).

GAAP has the meaning specified in accounting standards issued by the Government Accounting Standards Board (GASB) and the Financial Accounting Standards Board (FASB).

[↑ Back to Top](#)

§200.50 Generally Accepted Government Auditing Standards (GAGAS).

GAGAS, also known as the Yellow Book, means generally accepted government auditing standards issued by the Comptroller General of the United States, which are applicable to financial audits.

[78 FR 78608, Dec. 26, 2013, as amended at 79 FR 75880, Dec. 19, 2014]

[↑ Back to Top](#)

§200.51 Grant agreement.

Grant agreement means a legal instrument of financial assistance between a Federal awarding agency or pass-through entity and a non-Federal entity that, consistent with 31 U.S.C. 6302, 6304:

(a) Is used to enter into a relationship the principal purpose of which is to transfer anything of value from the Federal awarding agency or pass-through entity to the non-Federal entity to carry out a public purpose authorized by a law of the United States (see 31 U.S.C. 6101(3)); and not to acquire property or services for the Federal awarding agency or pass-through entity's direct benefit or use;

(b) Is distinguished from a cooperative agreement in that it does not provide for substantial involvement between the Federal awarding agency or pass-through entity and the non-Federal entity in carrying out the activity contemplated by the Federal award.

(c) Does not include an agreement that provides only:

(1) Direct United States Government cash assistance to an individual;

(2) A subsidy;

(3) A loan;

(4) A loan guarantee; or

(5) Insurance.

[↑ Back to Top](#)

§200.52 Hospital.

Hospital means a facility licensed as a hospital under the law of any state or a facility operated as a hospital by the United States, a state, or a subdivision of a state.

[↑ Back to Top](#)

§200.53 Improper payment.

(a) *Improper payment* means any payment that should not have been made or that was made in an incorrect amount (including overpayments and underpayments) under statutory, contractual, administrative, or other legally applicable requirements; and

(b) *Improper payment* includes any payment to an ineligible party, any payment for an ineligible good or service, any duplicate payment, any payment for a good or service not received (except for such payments where authorized by law), any payment that does not account for credit for applicable discounts, and any payment where insufficient or lack of documentation prevents a reviewer from discerning whether a payment was proper.

[↑ Back to Top](#)

§200.54 Indian tribe (or “federally recognized Indian tribe”).

Indian tribe means any Indian tribe, band, nation, or other organized group or community, including any Alaska Native village or regional or village corporation as defined in or established pursuant to the Alaska Native Claims Settlement Act (43 U.S.C. Chapter 33), which is recognized as eligible for the special programs and services provided by the United States to Indians because of their status as Indians (25 U.S.C. 450b(e)). See annually published Bureau of Indian Affairs list of Indian Entities Recognized and Eligible to Receive Services.

[↑ Back to Top](#)

§200.55 Institutions of Higher Education (IHEs).

IHE is defined at 20 U.S.C. 1001.

[↑ Back to Top](#)

§200.56 Indirect (facilities & administrative (F&A)) costs.

Indirect (F&A) costs means those costs incurred for a common or joint purpose benefitting more than one cost objective, and not readily assignable to the cost objectives specifically benefitted, without effort disproportionate to the results achieved. To facilitate equitable distribution of indirect expenses to the cost objectives served, it may be necessary to establish a number of pools of indirect (F&A) costs. Indirect (F&A) cost pools must be distributed to benefitted cost objectives on bases that will produce an equitable result in consideration of relative benefits derived.

[78 FR 78608, Dec. 26, 2013, as amended at 79 FR 75880, Dec. 19, 2014]

[↑ Back to Top](#)

§200.57 Indirect cost rate proposal.

Indirect cost rate proposal means the documentation prepared by a non-Federal entity to substantiate its request for the establishment of an indirect cost rate as described in Appendix III to Part 200—Indirect (F&A) Costs Identification and Assignment, and Rate Determination for Institutions of Higher Education (IHEs) through Appendix VII to Part 200—States and Local Government and Indian Tribe Indirect Cost Proposals of this part, and Appendix IX to Part 200—Hospital Cost Principles.

[78 FR 78608, Dec. 26, 2013, as amended at 79 FR 75880, Dec. 19, 2014]

[↑ Back to Top](#)

§200.58 Information technology systems.

Information technology systems means computing devices, ancillary equipment, software, firmware, and similar procedures, services (including support services), and related resources. See also §§200.20 Computing devices and 200.33 Equipment.

[↑ Back to Top](#)

§200.59 Intangible property.

Intangible property means property having no physical existence, such as trademarks, copyrights, patents and patent applications and property, such as loans, notes and other debt instruments, lease agreements, stock and other instruments of property ownership (whether the property is tangible or intangible).

[↑ Back to Top](#)

§200.60 Intermediate cost objective.

Intermediate cost objective means a cost objective that is used to accumulate indirect costs or service center costs that are subsequently allocated to one or more indirect cost pools or final cost objectives. See also §200.28 Cost objective and §200.44 Final cost objective.

[↑ Back to Top](#)

§200.61 Internal controls.

Internal controls means a process, implemented by a non-Federal entity, designed to provide reasonable assurance regarding the achievement of objectives in the following categories:

- (a) Effectiveness and efficiency of operations;
- (b) Reliability of reporting for internal and external use; and
- (c) Compliance with applicable laws and regulations.

[↑ Back to Top](#)

§200.62 Internal control over compliance requirements for Federal awards.

Internal control over compliance requirements for Federal awards means a process implemented by a non-Federal entity designed to provide reasonable assurance regarding the achievement of the following objectives for Federal awards:

(a) Transactions are properly recorded and accounted for, in order to:

- (1) Permit the preparation of reliable financial statements and Federal reports;
- (2) Maintain accountability over assets; and
- (3) Demonstrate compliance with Federal statutes, regulations, and the terms and conditions of the Federal award;

(b) Transactions are executed in compliance with:

- (1) Federal statutes, regulations, and the terms and conditions of the Federal award that could have a direct and material effect on a Federal program; and
- (2) Any other Federal statutes and regulations that are identified in the Compliance Supplement; and
- (c) Funds, property, and other assets are safeguarded against loss from unauthorized use or disposition.

[↑ Back to Top](#)

§200.63 Loan.

Loan means a Federal loan or loan guarantee received or administered by a non-Federal entity, except as used in the definition of §200.80 Program income.

(a) The term “direct loan” means a disbursement of funds by the Federal Government to a non-Federal borrower under a contract that requires the repayment of such funds with or without interest. The term includes the purchase of, or participation in, a loan made by another lender and financing arrangements that defer payment for more than 90 days, including the sale of a Federal Government asset on credit terms. The term does not include the acquisition of a federally guaranteed loan in satisfaction of default claims or the price support loans of the Commodity Credit Corporation.

(b) The term “direct loan obligation” means a binding agreement by a Federal awarding agency to make a direct loan when specified conditions are fulfilled by the borrower.

(c) The term “loan guarantee” means any Federal Government guarantee, insurance, or other pledge with respect to the payment of all or a part of the principal or interest on any debt obligation of a non-Federal borrower to a non-Federal lender, but does not include the insurance of deposits, shares, or other withdrawable accounts in financial institutions.

(d) The term “loan guarantee commitment” means a binding agreement by a Federal awarding agency to make a loan guarantee when specified conditions are fulfilled by the borrower, the lender, or any other party to the guarantee agreement.

[↑ Back to Top](#)

§200.64 Local government.

Local government means any unit of government within a state, including a:

- (a) County;
- (b) Borough;
- (c) Municipality;
- (d) City;
- (e) Town;
- (f) Township;
- (g) Parish;
- (h) Local public authority, including any public housing agency under the United States Housing Act of 1937;
- (i) Special district;
- (j) School district;
- (k) Intrastate district;
- (l) Council of governments, whether or not incorporated as a nonprofit corporation under state law; and
- (m) Any other agency or instrumentality of a multi-, regional, or intra-state or local government.

[↑ Back to Top](#)

§200.65 Major program.

Major program means a Federal program determined by the auditor to be a major program in accordance with §200.518 Major program determination or a program identified as a major program by a Federal awarding agency or pass-through entity in accordance with §200.503 Relation to other audit requirements, paragraph (e).

[↑ Back to Top](#)

§200.66 Management decision.

Management decision means the evaluation by the Federal awarding agency or pass-through entity of the audit findings and corrective action plan and the issuance of a written decision to the auditee as to what corrective action is necessary.

[↑ Back to Top](#)

§200.67 Micro-purchase.

Micro-purchase means a purchase of supplies or services using simplified acquisition procedures, the aggregate amount of which does not exceed the micro-purchase threshold. Micro-purchase procedures comprise a subset of a non-Federal entity's small purchase procedures. The non-Federal entity uses such procedures in order to expedite the completion of its lowest-dollar small purchase transactions and minimize the associated administrative burden and cost. The micro-purchase threshold is set by the Federal Acquisition Regulation at 48 CFR Subpart 2.1 (Definitions). It is \$3,000 except as otherwise discussed in Subpart 2.1 of that regulation, but this threshold is periodically adjusted for inflation.

[↑ Back to Top](#)

§200.68 Modified Total Direct Cost (MTDC).

MTDC means all direct salaries and wages, applicable fringe benefits, materials and supplies, services, travel, and up to the first \$25,000 of each subaward (regardless of the period of performance of the subawards under the award). MTDC excludes equipment, capital expenditures, charges for patient care, rental costs, tuition remission, scholarships and fellowships, participant support costs and the portion of each subaward in excess of \$25,000. Other items may only be excluded when necessary to avoid a serious inequity in the distribution of indirect costs, and with the approval of the cognizant agency for indirect costs.

[79 FR 75880, Dec. 19, 2014]

[↑ Back to Top](#)

§200.69 Non-Federal entity.

Non-Federal entity means a state, local government, Indian tribe, institution of higher education (IHE), or nonprofit organization that carries out a Federal award as a recipient or subrecipient.

[↑ Back to Top](#)

§200.70 Nonprofit organization.

Nonprofit organization means any corporation, trust, association, cooperative, or other organization, not including IHEs, that:

- (a) Is operated primarily for scientific, educational, service, charitable, or similar purposes in the public interest;
- (b) Is not organized primarily for profit; and
- (c) Uses net proceeds to maintain, improve, or expand the operations of the organization.

[↑ Back to Top](#)

§200.71 Obligations.

When used in connection with a non-Federal entity's utilization of funds under a Federal award, *obligations* means orders placed for property and services, contracts and subawards made, and similar transactions during a given period that require payment by the non-Federal entity during the same or a future period.

[↑ Back to Top](#)

§200.72 Office of Management and Budget (OMB).

OMB means the Executive Office of the President, Office of Management and Budget.

[↑ Back to Top](#)

§200.73 Oversight agency for audit.

Oversight agency for audit means the Federal awarding agency that provides the predominant amount of funding directly to a non-Federal entity not assigned a cognizant agency for audit. When there is no direct funding, the Federal awarding agency which is the predominant source of pass-through funding must assume the oversight responsibilities. The duties of the oversight agency for audit and the process for any reassignments are described in §200.513 Responsibilities, paragraph (b).

[↑ Back to Top](#)

§200.74 Pass-through entity.

Pass-through entity means a non-Federal entity that provides a subaward to a subrecipient to carry out part of a Federal program.

[↑ Back to Top](#)

§200.75 Participant support costs.

Participant support costs means direct costs for items such as stipends or subsistence allowances, travel allowances, and registration fees paid to or on behalf of participants or trainees (but not employees) in connection with conferences, or training projects.

[↑ Back to Top](#)

§200.76 Performance goal.

Performance goal means a target level of performance expressed as a tangible, measurable objective, against which actual achievement can be compared, including a goal expressed as a quantitative standard, value, or rate. In some instances (e.g., discretionary research awards), this may be limited to the requirement to submit technical performance reports (to be evaluated in accordance with agency policy).

[↑ Back to Top](#)

§200.77 Period of performance.

Period of performance means the time during which the non-Federal entity may incur new obligations to carry out the work authorized under the Federal award. The Federal awarding agency or pass-through entity must include start and end dates of the period of performance in the Federal award (see §§200.210 Information contained in a Federal award paragraph (a)(5) and 200.331 Requirements for pass-through entities, paragraph (a)(1)(iv)).

[↑ Back to Top](#)

§200.78 Personal property.

Personal property means property other than real property. It may be tangible, having physical existence, or intangible.

[↑ Back to Top](#)

§200.79 Personally Identifiable Information (PII).

PII means information that can be used to distinguish or trace an individual's identity, either alone or when combined with other personal or identifying information that is linked or linkable to a specific individual. Some information that is considered to be PII is available in public sources such as telephone books, public Web sites, and university listings. This type of information is considered to be Public PII and includes, for example, first and last name, address, work telephone number, email address, home telephone number, and general educational credentials. The definition of PII is not anchored to any single category of information or technology. Rather, it requires a case-by-case assessment of the specific risk that an individual can be identified. Non-PII can become PII whenever additional information is made publicly available, in any medium and from any source, that, when combined with other available information, could be used to identify an individual.

[↑ Back to Top](#)

§200.80 Program income.

Program income means gross income earned by the non-Federal entity that is directly generated by a supported activity or earned as a result of the Federal award during the period of performance except as provided in §200.307 paragraph (f). (See §200.77 Period of performance.) Program income includes but is not limited to income from fees for services performed, the use or rental of real or personal property acquired under Federal awards, the sale of commodities or items fabricated under a Federal award, license fees and royalties on patents and copyrights, and principal and interest on loans made with Federal award funds. Interest earned on advances of Federal funds is not program income. Except as otherwise provided in Federal statutes, regulations, or the terms and conditions of the Federal award, program income does not include rebates, credits, discounts, and interest earned on any of them. See also §200.407 Prior written approval (prior approval). See also 35 U.S.C. 200-212 "Disposition of Rights in Educational Awards" applies to inventions made under Federal awards.

[78 FR 78608, Dec. 26, 2013, as amended at 79 FR 75880, Dec. 19, 2014]

[↑ Back to Top](#)

§200.81 Property.

Property means real property or personal property.

[↑ Back to Top](#)

§200.82 Protected Personally Identifiable Information (Protected PII).

Protected PII means an individual's first name or first initial and last name in combination with any one or more of types of information, including, but not limited to, social security number, passport number, credit card numbers, clearances, bank numbers, biometrics, date and place of birth, mother's maiden name, criminal, medical and financial records, educational transcripts. This does not include PII that is required by law to be disclosed. (See also §200.79 Personally Identifiable Information (PII)).

[↑ Back to Top](#)

§200.83 Project cost.

Project cost means total allowable costs incurred under a Federal award and all required cost sharing and voluntary committed cost sharing, including third-party contributions.

[↑ Back to Top](#)

§200.84 Questioned cost.

Questioned cost means a cost that is questioned by the auditor because of an audit finding:

(a) Which resulted from a violation or possible violation of a statute, regulation, or the terms and conditions of a Federal award, including for funds used to match Federal funds;

(b) Where the costs, at the time of the audit, are not supported by adequate documentation; or

(c) Where the costs incurred appear unreasonable and do not reflect the actions a prudent person would take in the circumstances.

[↑ Back to Top](#)

§200.85 Real property.

Real property means land, including land improvements, structures and appurtenances thereto, but excludes moveable machinery and equipment.

[↑ Back to Top](#)

§200.86 Recipient.

Recipient means a non-Federal entity that receives a Federal award directly from a Federal awarding agency to carry out an activity under a Federal program. The term recipient does not include subrecipients. See also §200.69 Non-Federal entity.

[↑ Back to Top](#)

§200.87 Research and Development (R&D).

R&D means all research activities, both basic and applied, and all development activities that are performed by non-Federal entities. The term research also includes activities involving the training of individuals in research techniques where such activities utilize the same facilities as other research and development activities and where such activities are not included in the instruction function.

“Research” is defined as a systematic study directed toward fuller scientific knowledge or understanding of the subject studied. “Development” is the systematic use of knowledge and understanding gained from research directed toward the production of useful materials, devices, systems, or methods, including design and development of prototypes and processes.

[↑ Back to Top](#)

§200.88 Simplified acquisition threshold.

Simplified acquisition threshold means the dollar amount below which a non-Federal entity may purchase property or services using small purchase methods. Non-Federal entities adopt small purchase procedures in order to expedite the purchase of items costing less than the simplified acquisition threshold. The simplified acquisition threshold is set by the Federal Acquisition Regulation at 48 CFR Subpart 2.1 (Definitions) and in accordance with 41 U.S.C. 1908. As of the publication of this part, the simplified acquisition threshold is \$150,000, but this threshold is periodically adjusted for inflation. (Also see definition of §200.67 Micro-purchase.)

[↑ Back to Top](#)

§200.89 Special purpose equipment.

Special purpose equipment means equipment which is used only for research, medical, scientific, or other technical activities. Examples of special purpose equipment include microscopes, x-ray machines, surgical instruments, and spectrometers. See also §§200.33 Equipment and 200.48 General purpose equipment.

[↑ Back to Top](#)

§200.90 State.

State means any state of the United States, the District of Columbia, the Commonwealth of Puerto Rico, U.S. Virgin Islands, Guam, American Samoa, the Commonwealth of the Northern Mariana Islands, and any agency or instrumentality thereof exclusive of local governments.

[78 FR 78608, Dec. 26, 2013, as amended at 79 FR 75880, Dec. 19, 2014]

[↑ Back to Top](#)

§200.91 Student Financial Aid (SFA).

SFA means Federal awards under those programs of general student assistance, such as those authorized by Title IV of the Higher Education Act of 1965, as amended, (20 U.S.C. 1070-1099d), which are administered by the U.S. Department of Education, and similar programs provided by other Federal agencies. It does not include Federal awards under programs that provide fellowships or similar Federal awards to students on a competitive basis, or for specified studies or research.

[↑ Back to Top](#)

§200.92 Subaward.

Subaward means an award provided by a pass-through entity to a subrecipient for the subrecipient to carry out part of a Federal award received by the pass-through entity. It does not include payments to a contractor or payments to an individual that is a beneficiary of a Federal program. A subaward may be provided through any form of legal agreement, including an agreement that the pass-through entity considers a contract.

[↑ Back to Top](#)

§200.93 Subrecipient.

Subrecipient means a non-Federal entity that receives a subaward from a pass-through entity to carry out part of a Federal program; but does not include an individual that is a beneficiary of such program. A subrecipient may also be a recipient of other Federal awards directly from a Federal awarding agency.

[↑ Back to Top](#)

§200.94 Supplies.

Supplies means all tangible personal property other than those described in §200.33 Equipment. A computing device is a supply if the acquisition cost is less than the lesser of the capitalization level established by the non-Federal entity for financial statement purposes or \$5,000, regardless of the length of its useful life. See also §§200.20 Computing devices and 200.33 Equipment.

[↑ Back to Top](#)

§200.95 Termination.

Termination means the ending of a Federal award, in whole or in part at any time prior to the planned end of period of performance.

[↑ Back to Top](#)

§200.96 Third-party in-kind contributions.

Third-party in-kind contributions means the value of non-cash contributions (i.e., property or services) that—

- (a) Benefit a federally assisted project or program; and
- (b) Are contributed by non-Federal third parties, without charge, to a non-Federal entity under a Federal award.

[↑ Back to Top](#)

§200.97 Unliquidated obligations.

Unliquidated obligations means, for financial reports prepared on a cash basis, obligations incurred by the non-Federal entity that have not been paid (liquidated). For reports prepared on an accrual expenditure basis, these are obligations incurred by the non-Federal entity for which an expenditure has not been recorded.

[↑ Back to Top](#)

§200.98 Unobligated balance.

Unobligated balance means the amount of funds under a Federal award that the non-Federal entity has not obligated. The amount is computed by subtracting the cumulative amount of the non-Federal entity's unliquidated obligations and expenditures of funds under the Federal award from the cumulative amount of the funds that the Federal awarding agency or pass-through entity authorized the non-Federal entity to obligate.

[↑ Back to Top](#)

§200.99 Voluntary committed cost sharing.

Voluntary committed cost sharing means cost sharing specifically pledged on a voluntary basis in the proposal's budget or the Federal award on the part of the non-Federal entity and that becomes a binding requirement of Federal award.

[↑ Back to Top](#)

Subpart B—General Provisions

[↑ Back to Top](#)

§200.100 Purpose.

(a)(1) This part establishes uniform administrative requirements, cost principles, and audit requirements for Federal awards to non-Federal entities, as described in §200.101 Applicability. Federal awarding agencies must not impose additional or inconsistent requirements, except as provided in §§200.102 Exceptions and 200.210 Information contained in a Federal award, or unless specifically required by Federal statute, regulation, or Executive Order.

(2) This part provides the basis for a systematic and periodic collection and uniform submission by Federal agencies of information on all Federal financial assistance programs to the Office of Management and Budget (OMB). It also establishes Federal policies related to the delivery of this information to the public, including through the use of electronic media. It prescribes the manner in which General Services Administration (GSA), OMB, and Federal agencies that administer Federal financial assistance programs are to carry out their statutory responsibilities under the Federal Program Information Act (31 U.S.C. 6101-6106).

(b) *Administrative requirements.* Subparts B through D of this part set forth the uniform administrative requirements for grant and cooperative agreements, including the requirements for Federal awarding agency management of Federal grant programs before the Federal award has been made, and the requirements Federal awarding agencies may impose on non-Federal entities in the Federal award.

(c) *Cost Principles.* Subpart E—Cost Principles of this part establishes principles for determining the allowable costs incurred by non-Federal entities under Federal awards. The principles are for the purpose of cost determination and are not intended to identify the circumstances or dictate the extent of Federal Government participation in the financing of a particular program or project. The principles are designed to provide that Federal awards bear their fair share of cost recognized under these principles except where restricted or prohibited by statute.

(d) *Single Audit Requirements and Audit Follow-up.* Subpart F—Audit Requirements of this part is issued pursuant to the Single Audit Act Amendments of 1996, (31 U.S.C. 7501-7507). It sets forth standards for obtaining consistency and uniformity among Federal agencies for the audit of non-Federal entities expending Federal awards. These provisions also provide the policies and procedures for Federal awarding agencies and pass-through entities when using the results of these audits.

(e) For OMB guidance to Federal awarding agencies on Challenges and Prizes, please see M-10-11 Guidance on the Use of Challenges and Prizes to Promote Open Government, issued March 8, 2010, or its successor.

[↑ Back to Top](#)

§200.101 Applicability.

(a) *General applicability to Federal agencies.* The requirements established in this part apply to Federal agencies that make Federal awards to non-Federal entities. These requirements are applicable to all costs related to Federal awards.

(b)(1) *Applicability to different types of Federal awards.* The following table describes what portions of this part apply to which types of Federal awards. The terms and conditions of Federal awards (including this part) flow down to subawards to subrecipients unless a particular section of this part or the terms and conditions of the Federal award specifically indicate otherwise. This means that non-Federal entities must comply with requirements in this part regardless of whether the non-Federal entity is a recipient or subrecipient of a Federal award. Pass-through entities must comply with the requirements described in Subpart D—Post Federal Award Requirements of this part, §§200.330 Subrecipient and contractor determinations through 200.332 Fixed amount Subawards, but not any requirements in this part directed towards Federal awarding agencies unless the requirements of this part or the terms and conditions of the Federal award indicate otherwise.

This table must be read along with the other provisions of this section.		
The following portions of the Part:	Are applicable to the following types of Federal Awards (except as noted in paragraphs (d) and (e) below:	Are NOT applicable to the following types of Federal Awards:
Subpart A - Acronyms and Definitions	—All	
Subpart B - General Provisions, except for §§200.111 English Language, 200.112 Conflict of Interest, 200.113 Mandatory Disclosures	—All	
§§200.111 English Language, 200.112 Conflict of Interest, and 200.113 Mandatory Disclosures	—Grant agreements and cooperative agreements.	—Agreements for loans, loan guarantees, interest subsidies, and insurance. —Cost-reimbursement contracts awarded under the Federal Acquisition Regulations and cost-reimbursement subcontracts under these contracts. —Fixed-price contracts and subcontracts awarded under the Federal Acquisition Regulation whenever cost analysis is performed or the contract requires the determination or negotiation of costs.
Subparts C-D, except for Subrecipient Monitoring and Management	—Grant agreements and cooperative agreements.	—Agreements for loans, loan guarantees, interest subsidies, and insurance. —Cost-reimbursement contracts awarded under the Federal Acquisition Regulations and cost-reimbursement subcontracts under these contracts. —Fixed-price contracts and subcontracts awarded under the Federal Acquisition Regulation whenever cost analysis is performed or the contract requires the determination or negotiation of costs.
Subpart D—Post Federal Award Requirements, Subrecipient Monitoring and Management	—All	
Subpart E—Cost Principles	—Grant agreements and cooperative agreements, except those providing food commodities. —Cost-reimbursement contracts awarded under the Federal Acquisition Regulations and cost-reimbursement subcontracts under these contracts in accordance with the FAR. —Fixed-price contracts and subcontracts awarded under the Federal Acquisition Regulation whenever cost analysis is performed or the contract requires the determination or negotiation of costs.	—Grant agreements and cooperative agreements providing food commodities. —Fixed amount awards —Agreements for loans, loan guarantees, interest subsidies, insurance. —Federal awards to hospitals (see Appendix IX Hospital Cost Principles).
Subpart F—Audit Requirements	—All	

[View or download PDF](#)

(2) *Federal award of cost-reimbursement contract under the FAR to a non-Federal entity.* When a non-Federal entity is awarded a cost-reimbursement contract, only Subpart D—Post Federal Award Requirements of this part, §§200.330 Subrecipient and contractor determinations through 200.332 Fixed amount Subawards (in addition to any FAR related requirements for subaward monitoring), Subpart E—Cost Principles of this part and Subpart F—Audit Requirements of this part are incorporated by reference into the contract. However, when the Cost Accounting Standards (CAS) are applicable to the contract, they take precedence over the requirements of this part except for Subpart F—Audit Requirements of this part when they are in conflict. In addition, costs that are made unallowable under 10 U.S.C. 2324(e) and 41 U.S.C. 4304(a) as described in the FAR subpart 31.2 and subpart 31.603 are always unallowable. For requirements other than those covered in Subpart D—Post Federal Award Requirements of this part, §§200.330 Subrecipient and contractor determinations through 200.332 Fixed amount Subawards, Subpart E—Cost Principles of this part and Subpart F—Audit Requirements of this part, the terms of the contract and the FAR apply.

(3) With the exception of Subpart F—Audit Requirements of this part, which is required by the Single Audit Act, in any circumstances where the provisions of Federal statutes or regulations differ from the provisions of this part, the provision of the Federal statutes or regulations govern. This includes, for agreements with Indian tribes, the provisions of the Indian Self-Determination and Education and Assistance Act (ISDEAA), as amended, 25 U.S.C 450-458ddd-2.

(c) Federal awarding agencies may apply subparts A through E of this part to for-profit entities, foreign public entities, or foreign organizations, except where the Federal awarding agency determines that the application of these subparts would be inconsistent with the international obligations of the United States or the statutes or regulations of a foreign government.

(d) Except for §200.202 Requirement to provide public notice of Federal financial assistance programs and §§200.330 Subrecipient and contractor determinations through 200.332 Fixed amount Subawards of Subpart D—Post Federal Award Requirements of this part, the requirements in Subpart C—Pre-Federal Award Requirements and Contents of Federal Awards, Subpart D—Post Federal Award Requirements of this part, and Subpart E—Cost Principles of this part do not apply to the following programs:

- (1) The block grant awards authorized by the Omnibus Budget Reconciliation Act of 1981 (including Community Services, except to the extent that the cost and accounting standards of OMB apply to subrecipients of Community Services Block Grant funds pursuant to 42 U.S.C. 9916(a)(1)(B));
- (2) Federal awards to local education agencies under 20 U.S.C. 7702-7703b, (portions of the Impact Aid program);
- (3) Payments under the Department of Veterans Affairs' State Home Per Diem Program (38 U.S.C. 1741); and

(4) Federal awards authorized under the Child Care and Development Block Grant Act of 1990, as amended:

(i) Child Care and Development Block Grant (42 U.S.C. 9858)

(ii) Child Care Mandatory and Matching Funds of the Child Care and Development Fund (42 U.S.C. 9858)

(e) Except for §200.202 Requirement to provide public notice of Federal financial assistance programs the guidance in Subpart C—Pre-Federal Award Requirements and Contents of Federal Awards of this part does not apply to the following programs:

(1) Entitlement Federal awards to carry out the following programs of the Social Security Act:

(i) Temporary Assistance to Needy Families (title IV-A of the Social Security Act, 42 U.S.C. 601-619);

(ii) Child Support Enforcement and Establishment of Paternity (title IV-D of the Social Security Act, 42 U.S.C. 651-669b);

(iii) Foster Care and Adoption Assistance (title IV-E of the Act, 42 U.S.C. 670-679c);

(iv) Aid to the Aged, Blind, and Disabled (titles I, X, XIV, and XVI-AABD of the Act, as amended);

(v) Medical Assistance (Medicaid) (title XIX of the Act, 42 U.S.C. 1396-1396w-5) not including the State Medicaid Fraud Control program authorized by section 1903(a)(6)(B) of the Social Security Act (42 U.S.C. 1396b(a)(6)(B)); and

(vi) Children's Health Insurance Program (title XXI of the Act, 42 U.S.C. 1397aa-1397mm).

(2) A Federal award for an experimental, pilot, or demonstration project that is also supported by a Federal award listed in paragraph (e)(1) of this section;

(3) Federal awards under subsection 412(e) of the Immigration and Nationality Act and subsection 501(a) of the Refugee Education Assistance Act of 1980 (Pub. L. 96-422, 94 Stat. 1809), for cash assistance, medical assistance, and supplemental security income benefits to refugees and entrants and the administrative costs of providing the assistance and benefits (8 U.S.C. 1522(e));

(4) Entitlement awards under the following programs of The National School Lunch Act:

(i) National School Lunch Program (section 4 of the Act, 42 U.S.C. 1753),

(ii) Commodity Assistance (section 6 of the Act, 42 U.S.C. 1755),

(iii) Special Meal Assistance (section 11 of the Act, 42 U.S.C. 1759a),

(iv) Summer Food Service Program for Children (section 13 of the Act, 42 U.S.C. 1761), and

(v) Child and Adult Care Food Program (section 17 of the Act, 42 U.S.C. 1766).

(5) Entitlement awards under the following programs of The Child Nutrition Act of 1966:

(i) Special Milk Program (section 3 of the Act, 42 U.S.C. 1772),

(ii) School Breakfast Program (section 4 of the Act, 42 U.S.C. 1773), and

(iii) State Administrative Expenses (section 7 of the Act, 42 U.S.C. section 1776).

(6) Entitlement awards for State Administrative Expenses under The Food and Nutrition Act of 2008 (section 16 of the Act, 7 U.S.C. 2025).

(7) Non-discretionary Federal awards under the following non-entitlement programs:

(i) Special Supplemental Nutrition Program for Women, Infants and Children (section 17 of the Child Nutrition Act of 1966) 42 U.S.C. section 1786;

(ii) The Emergency Food Assistance Programs (Emergency Food Assistance Act of 1983) 7 U.S.C. section 7501 note; and

(iii) Commodity Supplemental Food Program (section 5 of the Agriculture and Consumer Protection Act of 1973) 7 U.S.C. section 612c note.

[78 FR 78608, Dec. 26, 2013, as amended at 79 FR 75880, Dec. 19, 2014]

[↑ Back to Top](#)

§200.102 Exceptions.

(a) With the exception of Subpart F—Audit Requirements of this part, OMB may allow exceptions for classes of Federal awards or non-Federal entities subject to the requirements of this part when exceptions are not prohibited by statute. However, in the interest of maximum uniformity, exceptions from the requirements of this part will be permitted only in unusual circumstances. Exceptions for classes of Federal awards or non-Federal entities will be published on the OMB Web site at www.whitehouse.gov/omb.

(b) Exceptions on a case-by-case basis for individual non-Federal entities may be authorized by the Federal awarding agency or cognizant agency for indirect costs, except where otherwise required by law or where OMB or other approval is expressly required by this part.

(c) The Federal awarding agency may apply more restrictive requirements to a class of Federal awards or non-Federal entities when approved by OMB, or when, required by Federal statutes or regulations, except for the requirements in Subpart F—Audit Requirements of this part. A Federal awarding agency may apply less restrictive requirements when making fixed amount awards as defined in Subpart A—Acronyms and Definitions of this part, except for those requirements imposed by statute or in Subpart F—Audit Requirements of this part.

(d) On a case-by-case basis, OMB will approve new strategies for Federal awards when proposed by the Federal awarding agency in accordance with OMB guidance (such as M-13-17) to develop additional evidence relevant to addressing important policy challenges or to promote cost-effectiveness in and across Federal programs. Proposals may draw on the innovative program designs discussed in M-13-17 to

expand or improve the use of effective practices in delivering Federal financial assistance while also encouraging innovation in service delivery. Proposals submitted to OMB in accordance with M-13-17 may include requests to waive requirements other than those in Subpart F—Audit Requirements of this part.

[78 FR 78608, Dec. 26, 2013, as amended at 79 FR 75880, Dec. 19, 2014]

[↑ Back to Top](#)

§200.103 Authorities.

This part is issued under the following authorities.

(a) Subpart B—General Provisions of this part through Subpart D—Post Federal Award Requirements of this part are authorized under 31 U.S.C. 503 (the Chief Financial Officers Act, Functions of the Deputy Director for Management), 31 U.S.C. 1111 (Improving Economy and Efficiency of the United States Government), 41 U.S.C. 1101-1131 (the Office of Federal Procurement Policy Act), Reorganization Plan No. 2 of 1970, and Executive Order 11541 (“Prescribing the Duties of the Office of Management and Budget and the Domestic Policy Council in the Executive Office of the President”), the Single Audit Act Amendments of 1996, (31 U.S.C. 7501-7507), as well as The Federal Program Information Act (Public Law 95-220 and Public Law 98-169, as amended, codified at 31 U.S.C. 6101-6106).

(b) Subpart E—Cost Principles of this part is authorized under the Budget and Accounting Act of 1921, as amended; the Budget and Accounting Procedures Act of 1950, as amended (31 U.S.C. 1101-1125); the Chief Financial Officers Act of 1990 (31 U.S.C. 503-504); Reorganization Plan No. 2 of 1970; and Executive Order No. 11541, “Prescribing the Duties of the Office of Management and Budget and the Domestic Policy Council in the Executive Office of the President.”

(c) Subpart F—Audit Requirements of this part is authorized under the Single Audit Act Amendments of 1996, (31 U.S.C. 7501-7507).

[↑ Back to Top](#)

§200.104 Supersession.

As described in §200.110 Effective/applicability date, this part supersedes the following OMB guidance documents and regulations under Title 2 of the Code of Federal Regulations:

(a) A-21, “Cost Principles for Educational Institutions” (2 CFR part 220);

(b) A-87, “Cost Principles for State, Local and Indian Tribal Governments” (2 CFR part 225) and also FEDERAL REGISTER notice 51 FR 552 (January 6, 1986);

(c) A-89, “Federal Domestic Assistance Program Information”;

(d) A-102, “Grant Awards and Cooperative Agreements with State and Local Governments”;

(e) A-110, “Uniform Administrative Requirements for Awards and Other Agreements with Institutions of Higher Education, Hospitals, and Other Nonprofit Organizations” (codified at 2 CFR 215);

(f) A-122, “Cost Principles for Non-Profit Organizations” (2 CFR part 230);

(g) A-133, “Audits of States, Local Governments and Non-Profit Organizations ”; and

(h) Those sections of A-50 related to audits performed under Subpart F—Audit Requirements of this part.

[78 FR 78608, Dec. 26, 2013, as amended at 79 FR 75882, Dec. 19, 2014]

[↑ Back to Top](#)

§200.105 Effect on other issuances.

For Federal awards subject to this part, all administrative requirements, program manuals, handbooks and other non-regulatory materials that are inconsistent with the requirements of this part must be superseded upon implementation of this part by the Federal agency, except to the extent they are required by statute or authorized in accordance with the provisions in §200.102 Exceptions.

[↑ Back to Top](#)

§200.106 Agency implementation.

The specific requirements and responsibilities of Federal agencies and non-Federal entities are set forth in this part. Federal agencies making Federal awards to non-Federal entities must implement the language in the Subpart C—Pre-Federal Award Requirements and Contents of Federal Awards of this part through Subpart F—Audit Requirements of this part in codified regulations unless different provisions are required by Federal statute or are approved by OMB.

[↑ Back to Top](#)

§200.107 OMB responsibilities.

OMB will review Federal agency regulations and implementation of this part, and will provide interpretations of policy requirements and assistance to ensure effective and efficient implementation. Any exceptions will be subject to approval by OMB. Exceptions will only be made in particular cases where adequate justification is presented.

[↑ Back to Top](#)

§200.108 Inquiries.

Inquiries concerning this part may be directed to the Office of Federal Financial Management Office of Management and Budget, in Washington, DC. Non-Federal entities' inquiries should be addressed to the Federal awarding agency, cognizant agency for indirect costs, cognizant or oversight agency for audit, or pass-through entity as appropriate.

[↑ Back to Top](#)

§200.109 Review date.

OMB will review this part at least every five years after December 26, 2013.

[↑ Back to Top](#)

§200.110 Effective/applicability date.

(a) The standards set forth in this part which affect administration of Federal awards issued by Federal awarding agencies become effective once implemented by Federal awarding agencies or when any future amendment to this part becomes final. Federal awarding agencies must implement the policies and procedures applicable to Federal awards by promulgating a regulation to be effective by December 26, 2014 unless different provisions are required by statute or approved by OMB. For the procurement standards in §§200.317-200.326, non-Federal entities may continue to comply with the procurement standards in previous OMB guidance (superseded by this part as described in §200.104) for one additional fiscal year after this part goes into effect. If a non-Federal entity chooses to use the previous procurement standards for an additional fiscal year before adopting the procurement standards in this part, the non-Federal entity must document this decision in their internal procurement policies.

(b) The standards set forth in Subpart F—Audit Requirements of this part and any other standards which apply directly to Federal agencies will be effective December 26, 2013 and will apply to audits of fiscal years beginning on or after December 26, 2014.

[78 FR 78608, Dec. 26, 2013, as amended at 79 FR 75882, Dec. 19, 2014]

[↑ Back to Top](#)

§200.111 English language.

(a) All Federal financial assistance announcements and Federal award information must be in the English language. Applications must be submitted in the English language and must be in the terms of U.S. dollars. If the Federal awarding agency receives applications in another currency, the Federal awarding agency will evaluate the application by converting the foreign currency to United States currency using the date specified for receipt of the application.

(b) Non-Federal entities may translate the Federal award and other documents into another language. In the event of inconsistency between any terms and conditions of the Federal award and any translation into another language, the English language meaning will control. Where a significant portion of the non-Federal entity's employees who are working on the Federal award are not fluent in English, the non-Federal entity must provide the Federal award in English and the language(s) with which employees are more familiar.

[↑ Back to Top](#)

§200.112 Conflict of interest.

The Federal awarding agency must establish conflict of interest policies for Federal awards. The non-Federal entity must disclose in writing any potential conflict of interest to the Federal awarding agency or pass-through entity in accordance with applicable Federal awarding agency policy.

[↑ Back to Top](#)

§200.113 Mandatory disclosures.

The non-Federal entity or applicant for a Federal award must disclose, in a timely manner, in writing to the Federal awarding agency or pass-through entity all violations of Federal criminal law involving fraud, bribery, or gratuity violations potentially affecting the Federal award. Failure to make required disclosures can result in any of the remedies described in §200.338 Remedies for noncompliance, including suspension or debarment. (See also 2 CFR part 180 and 31 U.S.C. 3321).

[↑ Back to Top](#)

Subpart C—Pre-Federal Award Requirements and Contents of Federal Awards

[↑ Back to Top](#)

§200.200 Purpose.

(a) Sections 200.201 Use of grant agreements (including fixed amount awards), cooperative agreements, and contracts through 200.208 Certifications and representations prescribe instructions and other pre-award matters to be used in the announcement and application process.

(b) Use of §§200.203 Notices of funding opportunities, 200.204 Federal awarding agency review of merit of proposals, 200.205 Federal awarding agency review of risk posed by applicants, and 200.207 Specific conditions, is required only for competitive Federal awards, but may also be used by the Federal awarding agency for non-competitive awards where appropriate or where required by Federal statute.

[78 FR 78608, Dec. 26, 2013, as amended at 79 FR 75882, Dec. 19, 2014]

[↑ Back to Top](#)

§200.201 Use of grant agreements (including fixed amount awards), cooperative agreements, and contracts.

(a) The Federal awarding agency or pass-through entity must decide on the appropriate instrument for the Federal award (i.e., grant agreement, cooperative agreement, or contract) in accordance with the Federal Grant and Cooperative Agreement Act (31 U.S.C. 6301-08).

(b) Fixed Amount Awards. In addition to the options described in paragraph (a) of this section, Federal awarding agencies, or pass-through entities as permitted in §200.332 Fixed amount subawards, may use fixed amount awards (see §200.45 Fixed amount awards) to which the following conditions apply:

(1) The Federal award amount is negotiated using the cost principles (or other pricing information) as a guide. The Federal awarding agency or pass-through entity may use fixed amount awards if the project scope is specific and if adequate cost, historical, or unit pricing data is available to establish a fixed amount award based on a reasonable estimate of actual cost. Payments are based on meeting specific requirements of the Federal award. Accountability is based on performance and results. Except in the case of termination before completion of the Federal award, there is no governmental review of the actual costs incurred by the non-Federal entity in performance of the award. Some of the ways in which the Federal award may be paid include, but are not limited to:

(i) In several partial payments, the amount of each agreed upon in advance, and the “milestone” or event triggering the payment also agreed upon in advance, and set forth in the Federal award;

(ii) On a unit price basis, for a defined unit or units, at a defined price or prices, agreed to in advance of performance of the Federal award and set forth in the Federal award; or,

(iii) In one payment at Federal award completion.

(2) A fixed amount award cannot be used in programs which require mandatory cost sharing or match.

(3) The non-Federal entity must certify in writing to the Federal awarding agency or pass-through entity at the end of the Federal award that the project or activity was completed or the level of effort was expended. If the required level of activity or effort was not carried out, the amount of the Federal award must be adjusted.

(4) Periodic reports may be established for each Federal award.

(5) Changes in principal investigator, project leader, project partner, or scope of effort must receive the prior written approval of the Federal awarding agency or pass-through entity.

[78 FR 78608, Dec. 26, 2013, as amended at 79 FR 75882, Dec. 19, 2014]

[↑ Back to Top](#)

§200.202 Requirement to provide public notice of Federal financial assistance programs.

(a) The Federal awarding agency must notify the public of Federal programs in the Catalog of Federal Domestic Assistance (CFDA), maintained by the General Services Administration (GSA).

(1) The CFDA, or any OMB-designated replacement, is the single, authoritative, governmentwide comprehensive source of Federal financial assistance program information produced by the executive branch of the Federal Government.

(2) The information that the Federal awarding agency must submit to GSA for approval by OMB is listed in paragraph (b) of this section. GSA must prescribe the format for the submission.

(3) The Federal awarding agency may not award Federal financial assistance without assigning it to a program that has been included in the CFDA as required in this section unless there are exigent circumstances requiring otherwise, such as timing requirements imposed by statute.

(b) For each program that awards discretionary Federal awards, non-discretionary Federal awards, loans, insurance, or any other type of Federal financial assistance, the Federal awarding agency must submit the following information to GSA:

(1) Program Description, Purpose, Goals and Measurement. A brief summary of the statutory or regulatory requirements of the program and its intended outcome. Where appropriate, the Program Description, Purpose, Goals, and Measurement should align with the strategic goals and objectives within the Federal awarding agency's performance plan and should support the Federal awarding agency's performance measurement, management, and reporting as required by Part 6 of OMB Circular A-11;

(2) Identification of whether the program makes Federal awards on a discretionary basis or the Federal awards are prescribed by Federal statute, such as in the case of formula grants.

(3) Projected total amount of funds available for the program. Estimates based on previous year funding are acceptable if current appropriations are not available at the time of the submission;

(4) Anticipated Source of Available Funds: The statutory authority for funding the program and, to the extent possible, agency, sub-agency, or, if known, the specific program unit that will issue the Federal awards, and associated funding identifier (e.g., Treasury Account Symbol(s));

(5) General Eligibility Requirements: The statutory, regulatory or other eligibility factors or considerations that determine the applicant's qualification for Federal awards under the program (e.g., type of non-Federal entity); and

(6) Applicability of Single Audit Requirements as required by Subpart F—Audit Requirements of this part.

[↑ Back to Top](#)

§200.203 Notices of funding opportunities.

For competitive grants and cooperative agreements, the Federal awarding agency must announce specific funding opportunities by providing the following information in a public notice:

(a) *Summary Information in Notices of Funding Opportunities.* The Federal awarding agency must display the following information posted on the OMB-designated governmentwide Web site for finding and applying for Federal financial assistance, in a location preceding the full text of the announcement:

(1) Federal Awarding Agency Name;

(2) Funding Opportunity Title;

(3) Announcement Type (whether the funding opportunity is the initial announcement of this funding opportunity or a modification of a previously announced opportunity);

(4) Funding Opportunity Number (required, if applicable). If the Federal awarding agency has assigned or will assign a number to the funding opportunity announcement, this number must be provided;

(5) Catalog of Federal Financial Assistance (CFDA) Number(s);

(6) Key Dates. Key dates include due dates for applications or Executive Order 12372 submissions, as well as for any letters of intent or pre-applications. For any announcement issued before a program's application materials are available, key dates also include the date on which those materials will be released; and any other additional information, as deemed applicable by the relevant Federal awarding agency.

(b) The Federal awarding agency must generally make all funding opportunities available for application for at least 60 calendar days. The Federal awarding agency may make a determination to have a less than 60 calendar day availability period but no funding opportunity should be available for less than 30 calendar days unless exigent circumstances require as determined by the Federal awarding agency head or delegate.

(c) *Full Text of Funding Opportunities.* The Federal awarding agency must include the following information in the full text of each funding opportunity. For specific instructions on the content required in this section, refer to Appendix I to Part 200—Full Text of Notice of Funding Opportunity to this part.

(1) Full programmatic description of the funding opportunity.

(2) Federal award information, including sufficient information to help an applicant make an informed decision about whether to submit an application. (See also §200.414 Indirect (F&A) costs, paragraph (c)(4)).

(3) Specific eligibility information, including any factors or priorities that affect an applicant's or its application's eligibility for selection.

(4) Application Preparation and Submission Information, including the applicable submission dates and time.

(5) Application Review Information including the criteria and process to be used to evaluate applications. See also §§200.204 Federal awarding agency review of merit proposals and 200.205 Federal awarding agency review of risk posed by applicants. See also 2 CFR part 27 (forthcoming at time of publication).

(6) Federal Award Administration Information. See also §200.210 Information contained in a Federal award.

[78 FR 78608, Dec. 26, 2013, as amended at 79 FR 75882, Dec. 19, 2014]

[↑ Back to Top](#)

§200.204 Federal awarding agency review of merit of proposals.

For competitive grants or cooperative agreements, unless prohibited by Federal statute, the Federal awarding agency must design and execute a merit review process for applications. This process must be described or incorporated by reference in the applicable funding opportunity (see Appendix I to this part, Full text of the Funding Opportunity.) See also §200.203 Notices of funding opportunities.

[↑ Back to Top](#)

§200.205 Federal awarding agency review of risk posed by applicants.

(a) Prior to making a Federal award, the Federal awarding agency is required by 31 U.S.C. 3321 and 41 U.S.C. 2313 note to review information available through any OMB-designated repositories of governmentwide eligibility qualification or financial integrity information, such as SAM Exclusions and "Do Not Pay". See also suspension and debarment requirements at 2 CFR part 180 as well as individual Federal agency suspension and debarment regulations in title 2 of the Code of Federal Regulations.

(b) In addition, for competitive grants or cooperative agreements, the Federal awarding agency must have in place a framework for evaluating the risks posed by applicants before they receive Federal awards. This evaluation may incorporate results of the evaluation of the applicant's eligibility or the quality of its application. If the Federal awarding agency determines that a Federal award will be made, special conditions that correspond to the degree of risk assessed may be applied to the Federal award. Criteria to be evaluated must be described in the announcement of funding opportunity described in §200.203 Notices of funding opportunities.

(c) In evaluating risks posed by applicants, the Federal awarding agency may use a risk-based approach and may consider any items such as the following:

(1) Financial stability;

(2) Quality of management systems and ability to meet the management standards prescribed in this part;

(3) History of performance. The applicant's record in managing Federal awards, if it is a prior recipient of Federal awards, including timeliness of compliance with applicable reporting requirements, conformance to the terms and conditions of previous Federal awards, and if applicable, the extent to which any previously awarded amounts will be expended prior to future awards;

(4) Reports and findings from audits performed under Subpart F—Audit Requirements of this part or the reports and findings of any other available audits; and

(5) The applicant's ability to effectively implement statutory, regulatory, or other requirements imposed on non-Federal entities.

(d) In addition to this review, the Federal awarding agency must comply with the guidelines on governmentwide suspension and debarment in 2 CFR part 180, and must require non-Federal entities to comply with these provisions. These provisions restrict Federal awards, subawards and contracts with certain parties that are debarred, suspended or otherwise excluded from or ineligible for participation in Federal programs or activities.

[78 FR 78608, Dec. 26, 2013, as amended at 79 FR 75882, Dec. 19, 2014]

[↑ Back to Top](#)

§200.206 Standard application requirements.

(a) *Paperwork clearances.* The Federal awarding agency may only use application information collections approved by OMB under the Paperwork Reduction Act of 1995 and OMB's implementing regulations in 5 CFR part 1320, Controlling Paperwork Burdens on the Public. Consistent with these requirements, OMB will authorize additional information collections only on a limited basis.

(b) If applicable, the Federal awarding agency may inform applicants and recipients that they do not need to provide certain information otherwise required by the relevant information collection.

[↑ Back to Top](#)

§200.207 Specific conditions.

(a) The Federal awarding agency or pass-through entity may impose additional specific award conditions as needed, in accordance with paragraphs (b) and (c) of this section, under the following circumstances:

- (1) Based on the criteria set forth in §200.205 Federal awarding agency review of risk posed by applicants;
 - (2) When an applicant or recipient has a history of failure to comply with the general or specific terms and conditions of a Federal award;
 - (3) When an applicant or recipient fails to meet expected performance goals as described in §200.210 Information contained in a Federal award; or
 - (4) When an applicant or recipient is not otherwise responsible.
- (b) These additional Federal award conditions may include items such as the following:
- (1) Requiring payments as reimbursements rather than advance payments;
 - (2) Withholding authority to proceed to the next phase until receipt of evidence of acceptable performance within a given period of performance;
 - (3) Requiring additional, more detailed financial reports;
 - (4) Requiring additional project monitoring;
 - (5) Requiring the non-Federal entity to obtain technical or management assistance; or
 - (6) Establishing additional prior approvals.
- (c) The Federal awarding agency or pass-through entity must notify the applicant or non-Federal entity as to:
- (1) The nature of the additional requirements;
 - (2) The reason why the additional requirements are being imposed;
 - (3) The nature of the action needed to remove the additional requirement, if applicable;
 - (4) The time allowed for completing the actions if applicable, and
 - (5) The method for requesting reconsideration of the additional requirements imposed.
- (d) Any specific conditions must be promptly removed once the conditions that prompted them have been corrected.

[79 FR 75882, Dec. 19, 2014]

[↑ Back to Top](#)

§200.208 Certifications and representations.

Unless prohibited by Federal statutes or regulations, each Federal awarding agency or pass-through entity is authorized to require the non-Federal entity to submit certifications and representations required by Federal statutes, or regulations on an annual basis. Submission may be required more frequently if the non-Federal entity fails to meet a requirement of a Federal award.

[↑ Back to Top](#)

§200.209 Pre-award costs.

For requirements on costs incurred by the applicant prior to the start date of the period of performance of the Federal award, see §200.458 Pre-award costs.

[↑ Back to Top](#)

§200.210 Information contained in a Federal award.

A Federal award must include the following information:

(a) *General Federal Award Information.* The Federal awarding agency must include the following general Federal award information in each Federal award:

- (1) Recipient name (which must match the name associated with its unique entity identifier as defined at 2 CFR 25.315);

- (2) Recipient's unique entity identifier;
- (3) Unique Federal Award Identification Number (FAIN);
- (4) Federal Award Date (see §200.39 Federal award date);
- (5) Period of Performance Start and End Date;
- (6) Amount of Federal Funds Obligated by this action;
- (7) Total Amount of Federal Funds Obligated;
- (8) Total Amount of the Federal Award;
- (9) Budget Approved by the Federal Awarding Agency;
- (10) Total Approved Cost Sharing or Matching, where applicable;
- (11) Federal award project description, (to comply with statutory requirements (e.g., FFATA));
- (12) Name of Federal awarding agency and contact information for awarding official,
- (13) CFDA Number and Name;
- (14) Identification of whether the award is R&D; and
- (15) Indirect cost rate for the Federal award (including if the de minimis rate is charged per §200.414 Indirect (F&A) costs).

(b) *General Terms and Conditions* (1) Federal awarding agencies must incorporate the following general terms and conditions either in the Federal award or by reference, as applicable:

(i) Administrative requirements implemented by the Federal awarding agency as specified in this part.

(ii) National policy requirements. These include statutory, executive order, other Presidential directive, or regulatory requirements that apply by specific reference and are not program-specific. See §200.300 Statutory and national policy requirements.

(2) The Federal award must include wording to incorporate, by reference, the applicable set of general terms and conditions. The reference must be to the Web site at which the Federal awarding agency maintains the general terms and conditions.

(3) If a non-Federal entity requests a copy of the full text of the general terms and conditions, the Federal awarding agency must provide it.

(4) Wherever the general terms and conditions are publicly available, the Federal awarding agency must maintain an archive of previous versions of the general terms and conditions, with effective dates, for use by the non-Federal entity, auditors, or others.

(c) *Federal Awarding Agency, Program, or Federal Award Specific Terms and Conditions*. The Federal awarding agency may include with each Federal award any terms and conditions necessary to communicate requirements that are in addition to the requirements outlined in the Federal awarding agency's general terms and conditions. Whenever practicable, these specific terms and conditions also should be shared on a public Web site and in notices of funding opportunities (as outlined in §200.203 Notices of funding opportunities) in addition to being included in a Federal award. See also §200.206 Standard application requirements.

(d) *Federal Award Performance Goals*. The Federal awarding agency must include in the Federal award an indication of the timing and scope of expected performance by the non-Federal entity as related to the outcomes intended to be achieved by the program. In some instances (e.g., discretionary research awards), this may be limited to the requirement to submit technical performance reports (to be evaluated in accordance with Federal awarding agency policy). Where appropriate, the Federal award may include specific performance goals, indicators, milestones, or expected outcomes (such as outputs, or services performed or public impacts of any of these) with an expected timeline for accomplishment. Reporting requirements must be clearly articulated such that, where appropriate, performance during the execution of the Federal award has a standard against which non-Federal entity performance can be measured. The Federal awarding agency may include program-specific requirements, as applicable. These requirements should be aligned with agency strategic goals, strategic objectives or performance goals that are relevant to the program. See also OMB Circular A-11, Preparation, Submission and Execution of the Budget Part 6 for definitions of strategic objectives and performance goals.

(e) Any other information required by the Federal awarding agency.

[78 FR 78608, Dec. 26, 2013, as amended at 79 FR 75882, Dec. 19, 2014]

[↑ Back to Top](#)

§200.211 Public access to Federal award information.

(a) In accordance with statutory requirements for Federal spending transparency (e.g., FFATA), except as noted in this section, for applicable Federal awards the Federal awarding agency must announce all Federal awards publicly and publish the required information on a publicly available OMB-designated governmentwide Web site (at time of publication, www.USAspending.gov).

(b) Nothing in this section may be construed as requiring the publication of information otherwise exempt under the Freedom of Information Act (5 U.S.C 552), or controlled unclassified information pursuant to Executive Order 13556.

[↑ Back to Top](#)

§200.212 Suspension and debarment.

Non-federal entities and contractors are subject to the non-procurement debarment and suspension regulations implementing Executive Orders 12549 and 12689, 2 CFR part 180. These regulations restrict awards, subawards, and contracts with certain parties that are debarred, suspended, or otherwise excluded from or ineligible for participation in Federal assistance programs or activities.

[79 FR 75883, Dec. 19, 2014]

[↑ Back to Top](#)

Subpart D—Post Federal Award Requirements

[↑ Back to Top](#)

STANDARDS FOR FINANCIAL AND PROGRAM MANAGEMENT

[↑ Back to Top](#)

§200.300 Statutory and national policy requirements.

(a) The Federal awarding agency must manage and administer the Federal award in a manner so as to ensure that Federal funding is expended and associated programs are implemented in full accordance with U.S. statutory and public policy requirements: including, but not limited to, those protecting public welfare, the environment, and prohibiting discrimination. The Federal awarding agency must communicate to the non-Federal entity all relevant public policy requirements, including those in general appropriations provisions, and incorporate them either directly or by reference in the terms and conditions of the Federal award.

(b) The non-Federal entity is responsible for complying with all requirements of the Federal award. For all Federal awards, this includes the provisions of FFATA, which includes requirements on executive compensation, and also requirements implementing the Act for the non-Federal entity at 2 CFR part 25 Financial Assistance Use of Universal Identifier and Central Contractor Registration and 2 CFR part 170 Reporting Subaward and Executive Compensation Information. See also statutory requirements for whistleblower protections at 10 U.S.C. 2409, 41 U.S.C. 4712, and 10 U.S.C. 2324, 41 U.S.C. 4304 and 4310.

[↑ Back to Top](#)

§200.301 Performance measurement.

The Federal awarding agency must require the recipient to use OMB-approved standard information collections when providing financial and performance information. As appropriate and in accordance with above mentioned information collections, the Federal awarding agency must require the recipient to relate financial data to performance accomplishments of the Federal award. Also, in accordance with above mentioned standard information collections, and when applicable, recipients must also provide cost information to demonstrate cost effective practices (e.g., through unit cost data). The recipient's performance should be measured in a way that will help the Federal awarding agency and other non-Federal entities to improve program outcomes, share lessons learned, and spread the adoption of promising practices. The Federal awarding agency should provide recipients with clear performance goals, indicators, and milestones as described in §200.210 Information contained in a Federal award. Performance reporting frequency and content should be established to not only allow the Federal awarding agency to understand the recipient progress but also to facilitate identification of promising practices among recipients and build the evidence upon which the Federal awarding agency's program and performance decisions are made.

[78 FR 78608, Dec. 26, 2013, as amended at 79 FR 75883, Dec. 19, 2014]

[↑ Back to Top](#)

§200.302 Financial management.

(a) Each state must expend and account for the Federal award in accordance with state laws and procedures for expending and accounting for the state's own funds. In addition, the state's and the other non-Federal entity's financial management systems, including records documenting compliance with Federal statutes, regulations, and the terms and conditions of the Federal award, must be sufficient to permit the preparation of reports required by general and program-specific terms and conditions; and the tracing of funds to a level of expenditures adequate to establish that such funds have been used according to the Federal statutes, regulations, and the terms and conditions of the Federal award. See also §200.450 Lobbying.

(b) The financial management system of each non-Federal entity must provide for the following (see also §§200.333 Retention requirements for records, 200.334 Requests for transfer of records, 200.335 Methods for collection, transmission and storage of information, 200.336 Access to records, and 200.337 Restrictions on public access to records):

(1) Identification, in its accounts, of all Federal awards received and expended and the Federal programs under which they were received. Federal program and Federal award identification must include, as applicable, the CFDA title and number, Federal award identification number and year, name of the Federal agency, and name of the pass-through entity, if any.

(2) Accurate, current, and complete disclosure of the financial results of each Federal award or program in accordance with the reporting requirements set forth in §§200.327 Financial reporting and 200.328 Monitoring and reporting program performance. If a Federal awarding agency requires reporting on an accrual basis from a recipient that maintains its records on other than an accrual basis, the recipient must not be required to establish an accrual accounting system. This recipient may develop accrual data for its reports on the basis of an analysis of the documentation on hand. Similarly, a pass-through entity must not require a subrecipient to establish an accrual accounting system and must allow the subrecipient to develop accrual data for its reports on the basis of an analysis of the documentation on hand.

(3) Records that identify adequately the source and application of funds for federally-funded activities. These records must contain information pertaining to Federal awards, authorizations, obligations, unobligated balances, assets, expenditures, income and interest and be supported by source documentation.

(4) Effective control over, and accountability for, all funds, property, and other assets. The non-Federal entity must adequately safeguard all assets and assure that they are used solely for authorized purposes. See §200.303 Internal controls.

(5) Comparison of expenditures with budget amounts for each Federal award.

(6) Written procedures to implement the requirements of §200.305 Payment.

(7) Written procedures for determining the allowability of costs in accordance with Subpart E—Cost Principles of this part and the terms and conditions of the Federal award.

[↑ Back to Top](#)

§200.303 Internal controls.

The non-Federal entity must:

(a) Establish and maintain effective internal control over the Federal award that provides reasonable assurance that the non-Federal entity is managing the Federal award in compliance with Federal statutes, regulations, and the terms and conditions of the Federal award. These internal controls should be in compliance with guidance in "Standards for Internal Control in the Federal Government" issued by the Comptroller General of the United States or the "Internal Control Integrated Framework", issued by the Committee of Sponsoring Organizations of the Treadway Commission (COSO).

(b) Comply with Federal statutes, regulations, and the terms and conditions of the Federal awards.

(c) Evaluate and monitor the non-Federal entity's compliance with statutes, regulations and the terms and conditions of Federal awards.

(d) Take prompt action when instances of noncompliance are identified including noncompliance identified in audit findings.

(e) Take reasonable measures to safeguard protected personally identifiable information and other information the Federal awarding agency or pass-through entity designates as sensitive or the non-Federal entity considers sensitive consistent with applicable Federal, state, local, and tribal laws regarding privacy and obligations of confidentiality.

[, as amended at 79 FR 75883, Dec. 19, 2014]

[↑ Back to Top](#)

§200.304 Bonds.

The Federal awarding agency may include a provision on bonding, insurance, or both in the following circumstances:

(a) Where the Federal Government guarantees or insures the repayment of money borrowed by the recipient, the Federal awarding agency, at its discretion, may require adequate bonding and insurance if the bonding and insurance requirements of the non-Federal entity are not deemed adequate to protect the interest of the Federal Government.

(b) The Federal awarding agency may require adequate fidelity bond coverage where the non-Federal entity lacks sufficient coverage to protect the Federal Government's interest.

(c) Where bonds are required in the situations described above, the bonds must be obtained from companies holding certificates of authority as acceptable sureties, as prescribed in 31 CFR Part 223, "Surety Companies Doing Business with the United States."

[↑ Back to Top](#)

§200.305 Payment.

(a) For states, payments are governed by Treasury-State CMLA agreements and default procedures codified at 31 CFR Part 205 "Rules and Procedures for Efficient Federal-State Funds Transfers" and TFM 4A-2000 Overall Disbursing Rules for All Federal Agencies.

(b) For non-Federal entities other than states, payments methods must minimize the time elapsing between the transfer of funds from the United States Treasury or the pass-through entity and the disbursement by the non-Federal entity whether the payment is made by electronic funds transfer, or issuance or redemption of checks, warrants, or payment by other means. See also §200.302 Financial management paragraph (b)(6). Except as noted elsewhere in this part, Federal agencies must require recipients to use only OMB-approved standard governmentwide information collection requests to request payment.

(1) The non-Federal entity must be paid in advance, provided it maintains or demonstrates the willingness to maintain both written procedures that minimize the time elapsing between the transfer of funds and disbursement by the non-Federal entity, and financial management systems that meet the standards for fund control and accountability as established in this part. Advance payments to a non-Federal entity must be limited to the minimum amounts needed and be timed to be in accordance with the actual, immediate cash requirements of the non-Federal entity in carrying out the purpose of the approved program or project. The timing and amount of advance payments must be as close as is administratively feasible to the actual disbursements by the non-Federal entity for direct program or project costs and the proportionate share of any allowable indirect costs. The non-Federal entity must make timely payment to contractors in accordance with the contract provisions.

(2) Whenever possible, advance payments must be consolidated to cover anticipated cash needs for all Federal awards made by the Federal awarding agency to the recipient.

(i) Advance payment mechanisms include, but are not limited to, Treasury check and electronic funds transfer and must comply with applicable guidance in 31 CFR part 208.

(ii) Non-Federal entities must be authorized to submit requests for advance payments and reimbursements at least monthly when electronic fund transfers are not used, and as often as they like when electronic transfers are used, in accordance with the provisions of the Electronic Fund Transfer Act (15 U.S.C. 1693-1693r).

(3) Reimbursement is the preferred method when the requirements in paragraph (b) cannot be met, when the Federal awarding agency sets a specific condition per §200.207 Specific conditions, or when the non-Federal entity requests payment by reimbursement. This method may be used on any Federal award for construction, or if the major portion of the construction project is accomplished through private market financing or Federal loans, and the Federal award constitutes a minor portion of the project. When the reimbursement method is used, the Federal awarding agency or pass-through entity must make payment within 30 calendar days after receipt of the billing, unless the Federal awarding agency or pass-through entity reasonably believes the request to be improper.

(4) If the non-Federal entity cannot meet the criteria for advance payments and the Federal awarding agency or pass-through entity has determined that reimbursement is not feasible because the non-Federal entity lacks sufficient working capital, the Federal awarding agency or pass-through entity may provide cash on a working capital advance basis. Under this procedure, the Federal awarding agency or pass-through entity must advance cash payments to the non-Federal entity to cover its estimated disbursement needs for an initial period generally geared to the non-Federal entity's disbursing cycle. Thereafter, the Federal awarding agency or pass-through entity must reimburse the non-Federal entity

for its actual cash disbursements. Use of the working capital advance method of payment requires that the pass-through entity provide timely advance payments to any subrecipients in order to meet the subrecipient's actual cash disbursements. The working capital advance method of payment must not be used by the pass-through entity if the reason for using this method is the unwillingness or inability of the pass-through entity to provide timely advance payments to the subrecipient to meet the subrecipient's actual cash disbursements.

(5) Use of resources before requesting cash advance payments. To the extent available, the non-Federal entity must disburse funds available from program income (including repayments to a revolving fund), rebates, refunds, contract settlements, audit recoveries, and interest earned on such funds before requesting additional cash payments.

(6) Unless otherwise required by Federal statutes, payments for allowable costs by non-Federal entities must not be withheld at any time during the period of performance unless the conditions of §§200.207 Specific conditions, Subpart D—Post Federal Award Requirements of this part, 200.338 Remedies for Noncompliance, or one or more of the following applies:

(i) The non-Federal entity has failed to comply with the project objectives, Federal statutes, regulations, or the terms and conditions of the Federal award.

(ii) The non-Federal entity is delinquent in a debt to the United States as defined in OMB Guidance A-129, "Policies for Federal Credit Programs and Non-Tax Receivables." Under such conditions, the Federal awarding agency or pass-through entity may, upon reasonable notice, inform the non-Federal entity that payments must not be made for obligations incurred after a specified date until the conditions are corrected or the indebtedness to the Federal Government is liquidated.

(iii) A payment withheld for failure to comply with Federal award conditions, but without suspension of the Federal award, must be released to the non-Federal entity upon subsequent compliance. When a Federal award is suspended, payment adjustments will be made in accordance with §200.342 Effects of suspension and termination.

(iv) A payment must not be made to a non-Federal entity for amounts that are withheld by the non-Federal entity from payment to contractors to assure satisfactory completion of work. A payment must be made when the non-Federal entity actually disburses the withheld funds to the contractors or to escrow accounts established to assure satisfactory completion of work.

(7) Standards governing the use of banks and other institutions as depositories of advance payments under Federal awards are as follows.

(i) The Federal awarding agency and pass-through entity must not require separate depository accounts for funds provided to a non-Federal entity or establish any eligibility requirements for depositories for funds provided to the non-Federal entity. However, the non-Federal entity must be able to account for the receipt, obligation and expenditure of funds.

(ii) Advance payments of Federal funds must be deposited and maintained in insured accounts whenever possible.

(8) The non-Federal entity must maintain advance payments of Federal awards in interest-bearing accounts, unless the following apply.

(i) The non-Federal entity receives less than \$120,000 in Federal awards per year.

(ii) The best reasonably available interest-bearing account would not be expected to earn interest in excess of \$500 per year on Federal cash balances.

(iii) The depository would require an average or minimum balance so high that it would not be feasible within the expected Federal and non-Federal cash resources.

(iv) A foreign government or banking system prohibits or precludes interest bearing accounts.

(9) Interest earned amounts up to \$500 per year may be retained by the non-Federal entity for administrative expense. Any additional interest earned on Federal advance payments deposited in interest-bearing accounts must be remitted annually to the Department of Health and Human Services Payment Management System (PMS) through an electronic medium using either Automated Clearing House (ACH) network or a Fedwire Funds Service payment. Remittances must include pertinent information of the payee and nature of payment in the memo area (often referred to as "addenda records" by Financial Institutions) as that will assist in the timely posting of interested earned on federal funds. Pertinent details include the Payee Account Number (PAN) if the payment originated from PMS, or Agency information if the payment originated from ASAP, NSF or another federal agency payment system. The remittance must be submitted as follows:

(i) For ACH Returns:

Routing Number: 051036706

Account number: 303000

Bank Name and Location: Credit Gateway—ACH Receiver St. Paul, MN

(ii) For Fedwire Returns*:

Routing Number: 021030004

Account number: 75010501

Bank Name and Location: Federal Reserve Bank Treas NYC/Funds Transfer Division New York, NY

(* Please note organization initiating payment is likely to incur a charge from your Financial Institution for this type of payment)

(iii) For International ACH Returns:

Beneficiary Account: Federal Reserve Bank of New York/ITS (FRBNY/ITS)

Bank: Citibank N.A. (New York)

Swift Code: CITIUS33

Account Number: 36838868

Bank Address: 388 Greenwich Street, New York, NY 10013 USA

Payment Details (Line 70): Agency

Name (abbreviated when possible) and ALC Agency POC: Michelle Haney, (301) 492-5065

(iv) For recipients that do not have electronic remittance capability, please make check** payable to: "The Department of Health and Human Services."

Mail Check to Treasury approved lockbox:

HHS Program Support Center, P.O. Box 530231, Atlanta, GA 30353-0231

(** Please allow 4-6 weeks for processing of a payment by check to be applied to the appropriate PMS account)

(v) Any additional information/instructions may be found on the PMS Web site at <http://www.dpm.psc.gov/>.

[78 FR 78608, Dec. 26, 2013, as amended at 79 FR 75883, Dec. 19, 2014]

[↑ Back to Top](#)

§200.306 Cost sharing or matching.

(a) Under Federal research proposals, voluntary committed cost sharing is not expected. It cannot be used as a factor during the merit review of applications or proposals, but may be considered if it is both in accordance with Federal awarding agency regulations and specified in a notice of funding opportunity. Criteria for considering voluntary committed cost sharing and any other program policy factors that may be used to determine who may receive a Federal award must be explicitly described in the notice of funding opportunity. See also §§200.414 Indirect (F&A) costs, 200.203 Notices of funding opportunities, and Appendix I to Part 200—Full Text of Notice of Funding Opportunity.

(b) For all Federal awards, any shared costs or matching funds and all contributions, including cash and third party in-kind contributions, must be accepted as part of the non-Federal entity's cost sharing or matching when such contributions meet all of the following criteria:

- (1) Are verifiable from the non-Federal entity's records;
- (2) Are not included as contributions for any other Federal award;
- (3) Are necessary and reasonable for accomplishment of project or program objectives;
- (4) Are allowable under Subpart E—Cost Principles of this part;

(5) Are not paid by the Federal Government under another Federal award, except where the Federal statute authorizing a program specifically provides that Federal funds made available for such program can be applied to matching or cost sharing requirements of other Federal programs;

(6) Are provided for in the approved budget when required by the Federal awarding agency; and

(7) Conform to other provisions of this part, as applicable.

(c) Unrecovered indirect costs, including indirect costs on cost sharing or matching may be included as part of cost sharing or matching only with the prior approval of the Federal awarding agency. Unrecovered indirect cost means the difference between the amount charged to the Federal award and the amount which could have been charged to the Federal award under the non-Federal entity's approved negotiated indirect cost rate.

(d) Values for non-Federal entity contributions of services and property must be established in accordance with the cost principles in Subpart E—Cost Principles. If a Federal awarding agency authorizes the non-Federal entity to donate buildings or land for construction/facilities acquisition projects or long-term use, the value of the donated property for cost sharing or matching must be the lesser of paragraphs (d)(1) or (2) of this section.

(1) The value of the remaining life of the property recorded in the non-Federal entity's accounting records at the time of donation.

(2) The current fair market value. However, when there is sufficient justification, the Federal awarding agency may approve the use of the current fair market value of the donated property, even if it exceeds the value described in (1) above at the time of donation.

(e) Volunteer services furnished by third-party professional and technical personnel, consultants, and other skilled and unskilled labor may be counted as cost sharing or matching if the service is an integral and necessary part of an approved project or program. Rates for third-party volunteer services must be consistent with those paid for similar work by the non-Federal entity. In those instances in which the required skills are not found in the non-Federal entity, rates must be consistent with those paid for similar work in the labor market in which the non-Federal entity competes for the kind of services involved. In either case, paid fringe benefits that are reasonable, necessary, allocable, and otherwise allowable may be included in the valuation.

(f) When a third-party organization furnishes the services of an employee, these services must be valued at the employee's regular rate of pay plus an amount of fringe benefits that is reasonable, necessary, allocable, and otherwise allowable, and indirect costs at either the third-party organization's approved federally negotiated indirect cost rate or, a rate in accordance with §200.414 Indirect (F&A) costs, paragraph (d), provided these services employ the same skill(s) for which the employee is normally paid. Where donated services are treated as indirect costs, indirect cost rates will separate the value of the donated services so that reimbursement for the donated services will not be made.

(g) Donated property from third parties may include such items as equipment, office supplies, laboratory supplies, or workshop and classroom supplies. Value assessed to donated property included in the cost sharing or matching share must not exceed the fair market value of the property at the time of the donation.

(h) The method used for determining cost sharing or matching for third-party-donated equipment, buildings and land for which title passes to the non-Federal entity may differ according to the purpose of the Federal award, if paragraph (h)(1) or (2) of this section applies.

(1) If the purpose of the Federal award is to assist the non-Federal entity in the acquisition of equipment, buildings or land, the aggregate value of the donated property may be claimed as cost sharing or matching.

(2) If the purpose of the Federal award is to support activities that require the use of equipment, buildings or land, normally only depreciation charges for equipment and buildings may be made. However, the fair market value of equipment or other capital assets and fair rental charges for land may be allowed, provided that the Federal awarding agency has approved the charges. See also §200.420 Considerations for selected items of cost.

(i) The value of donated property must be determined in accordance with the usual accounting policies of the non-Federal entity, with the following qualifications:

(1) The value of donated land and buildings must not exceed its fair market value at the time of donation to the non-Federal entity as established by an independent appraiser (e.g., certified real property appraiser or General Services Administration representative) and certified by a responsible official of the non-Federal entity as required by the Uniform Relocation Assistance and Real Property Acquisition Policies Act of 1970, as amended, (42 U.S.C. 4601-4655) (Uniform Act) except as provided in the implementing regulations at 49 CFR part 24.

(2) The value of donated equipment must not exceed the fair market value of equipment of the same age and condition at the time of donation.

(3) The value of donated space must not exceed the fair rental value of comparable space as established by an independent appraisal of comparable space and facilities in a privately-owned building in the same locality.

(4) The value of loaned equipment must not exceed its fair rental value.

(j) For third-party in-kind contributions, the fair market value of goods and services must be documented and to the extent feasible supported by the same methods used internally by the non-Federal entity.

(k) For IHEs, see also OMB memorandum M-01-06, dated January 5, 2001, Clarification of OMB A-21 Treatment of Voluntary Uncommitted Cost Sharing and Tuition Remission Costs.

[78 FR 78608, Dec. 26, 2013, as amended at 79 FR 75883, Dec. 19, 2014]

[↑ Back to Top](#)

§200.307 Program income.

(a) *General.* Non-Federal entities are encouraged to earn income to defray program costs where appropriate.

(b) *Cost of generating program income.* If authorized by Federal regulations or the Federal award, costs incidental to the generation of program income may be deducted from gross income to determine program income, provided these costs have not been charged to the Federal award.

(c) *Governmental revenues.* Taxes, special assessments, levies, fines, and other such revenues raised by a non-Federal entity are not program income unless the revenues are specifically identified in the Federal award or Federal awarding agency regulations as program income.

(d) *Property.* Proceeds from the sale of real property, equipment, or supplies are not program income; such proceeds will be handled in accordance with the requirements of Subpart D—Post Federal Award Requirements of this part, Property Standards §§200.311 Real property, 200.313 Equipment, and 200.314 Supplies, or as specifically identified in Federal statutes, regulations, or the terms and conditions of the Federal award.

(e) *Use of program income.* If the Federal awarding agency does not specify in its regulations or the terms and conditions of the Federal award, or give prior approval for how program income is to be used, paragraph (e)(1) of this section must apply. For Federal awards made to IHEs and nonprofit research institutions, if the Federal awarding agency does not specify in its regulations or the terms and conditions of the Federal award how program income is to be used, paragraph (e)(2) of this section must apply. In specifying alternatives to paragraphs (e)(1) and (2) of this section, the Federal awarding agency may distinguish between income earned by the recipient and income earned by subrecipients and between the sources, kinds, or amounts of income. When the Federal awarding agency authorizes the approaches in paragraphs (e)(2) and (3) of this section, program income in excess of any amounts specified must also be deducted from expenditures.

(1) *Deduction.* Ordinarily program income must be deducted from total allowable costs to determine the net allowable costs. Program income must be used for current costs unless the Federal awarding agency authorizes otherwise. Program income that the non-Federal entity did not anticipate at the time of the Federal award must be used to reduce the Federal award and non-Federal entity contributions rather than to increase the funds committed to the project.

(2) *Addition.* With prior approval of the Federal awarding agency (except for IHEs and nonprofit research institutions, as described in paragraph (e) of this section) program income may be added to the Federal award by the Federal agency and the non-Federal entity. The program income must be used for the purposes and under the conditions of the Federal award.

(3) *Cost sharing or matching.* With prior approval of the Federal awarding agency, program income may be used to meet the cost sharing or matching requirement of the Federal award. The amount of the Federal award remains the same.

(f) *Income after the period of performance.* There are no Federal requirements governing the disposition of income earned after the end of the period of performance for the Federal award, unless the Federal awarding agency regulations or the terms and conditions of the Federal award provide otherwise. The Federal awarding agency may negotiate agreements with recipients regarding appropriate uses of income earned after the period of performance as part of the grant closeout process. See also §200.343 Closeout.

(g) Unless the Federal statute, regulations, or terms and conditions for the Federal award provide otherwise, the non-Federal entity has no obligation to the Federal awarding agency with respect to program income earned from license fees and royalties for copyrighted material, patents, patent applications, trademarks, and inventions made under a Federal award to which 37 CFR part 401, "Rights to Inventions Made by Nonprofit Organizations and Small Business Firms Under Government Awards, Contracts and Cooperative Agreements" is applicable.

[78 FR 78608, Dec. 26, 2013, as amended at 79 FR 75884, Dec. 19, 2014]

[↑ Back to Top](#)

§200.308 Revision of budget and program plans.

(a) The approved budget for the Federal award summarizes the financial aspects of the project or program as approved during the Federal award process. It may include either the Federal and non-Federal share (see §200.43 Federal share) or only the Federal share, depending upon Federal awarding agency requirements. It must be related to performance for program evaluation purposes whenever appropriate.

(b) Recipients are required to report deviations from budget or project scope or objective, and request prior approvals from Federal awarding agencies for budget and program plan revisions, in accordance with this section.

(c) For non-construction Federal awards, recipients must request prior approvals from Federal awarding agencies for one or more of the following program or budget-related reasons:

(1) Change in the scope or the objective of the project or program (even if there is no associated budget revision requiring prior written approval).

(2) Change in a key person specified in the application or the Federal award.

(3) The disengagement from the project for more than three months, or a 25 percent reduction in time devoted to the project, by the approved project director or principal investigator.

(4) The inclusion, unless waived by the Federal awarding agency, of costs that require prior approval in accordance with Subpart E—Cost Principles of this part or 45 CFR part 75 Appendix IX, "Principles for Determining Costs Applicable to Research and Development under Awards and Contracts with Hospitals," or 48 CFR part 31, "Contract Cost Principles and Procedures," as applicable.

(5) The transfer of funds budgeted for participant support costs as defined in §200.75 Participant support costs to other categories of expense.

(6) Unless described in the application and funded in the approved Federal awards, the subawarding, transferring or contracting out of any work under a Federal award, including fixed amount subawards as described in §200.332 Fixed amount subawards. This provision does not apply to the acquisition of supplies, material, equipment or general support services.

(7) Changes in the approved cost-sharing or matching provided by the non-Federal entity. No other prior approval requirements for specific items may be imposed unless an exception has been approved by OMB. See also §§200.102 Exceptions and 200.407 Prior written approval (prior approval).

(8) The need arises for additional Federal funds to complete the project.

(d) Except for requirements listed in paragraph (c)(1) of this section, the Federal awarding agency is authorized, at its option, to waive prior written approvals required by paragraph (c) this section. Such waivers may include authorizing recipients to do any one or more of the following:

(1) Incur project costs 90 calendar days before the Federal awarding agency makes the Federal award. Expenses more than 90 calendar days pre-award require prior approval of the Federal awarding agency. All costs incurred before the Federal awarding agency makes the Federal award are at the recipient's risk (i.e., the Federal awarding agency is under no obligation to reimburse such costs if for any reason the recipient does not receive a Federal award or if the Federal award is less than anticipated and inadequate to cover such costs). See also §200.458 Pre-award costs.

(2) Initiate a one-time extension of the period of performance by up to 12 months unless one or more of the conditions outlined in paragraphs (d)(2)(i) through (iii) of this section apply. For one-time extensions, the recipient must notify the Federal awarding agency in writing with the supporting reasons and revised period of performance at least 10 calendar days before the end of the period of performance specified in the Federal award. This one-time extension may not be exercised merely for the purpose of using unobligated balances. Extensions require explicit prior Federal awarding agency approval when:

(i) The terms and conditions of the Federal award prohibit the extension.

(ii) The extension requires additional Federal funds.

(iii) The extension involves any change in the approved objectives or scope of the project.

(3) Carry forward unobligated balances to subsequent periods of performance.

(4) For Federal awards that support research, unless the Federal awarding agency provides otherwise in the Federal award or in the Federal awarding agency's regulations, the prior approval requirements described in paragraph (d) are automatically waived (i.e., recipients need not obtain such prior approvals) unless one of the conditions included in paragraph (d)(2) applies.

(e) The Federal awarding agency may, at its option, restrict the transfer of funds among direct cost categories or programs, functions and activities for Federal awards in which the Federal share of the project exceeds the Simplified Acquisition Threshold and the cumulative amount of such transfers exceeds or is expected to exceed 10 percent of the total budget as last approved by the Federal awarding agency. The Federal awarding agency cannot permit a transfer that would cause any Federal appropriation to be used for purposes other than those consistent with the appropriation.

(f) All other changes to non-construction budgets, except for the changes described in paragraph (c) of this section, do not require prior approval (see also §200.407 Prior written approval (prior approval)).

(g) For construction Federal awards, the recipient must request prior written approval promptly from the Federal awarding agency for budget revisions whenever paragraph (g)(1), (2), or (3) of this section applies.

(1) The revision results from changes in the scope or the objective of the project or program.

(2) The need arises for additional Federal funds to complete the project.

(3) A revision is desired which involves specific costs for which prior written approval requirements may be imposed consistent with applicable OMB cost principles listed in Subpart E—Cost Principles of this part.

(4) No other prior approval requirements for budget revisions may be imposed unless an exception has been approved by OMB.

(5) When a Federal awarding agency makes a Federal award that provides support for construction and non-construction work, the Federal awarding agency may require the recipient to obtain prior approval from the Federal awarding agency before making any fund or budget transfers between the two types of work supported.

(h) When requesting approval for budget revisions, the recipient must use the same format for budget information that was used in the application, unless the Federal awarding agency indicates a letter of request suffices.

(i) Within 30 calendar days from the date of receipt of the request for budget revisions, the Federal awarding agency must review the request and notify the recipient whether the budget revisions have been approved. If the revision is still under consideration at the end of 30 calendar days, the Federal awarding agency must inform the recipient in writing of the date when the recipient may expect the decision.

[78 FR 78608, Dec. 26, 2013, as amended at 79 FR 75884, Dec. 19, 2014]

[↑ Back to Top](#)

§200.309 Period of performance.

A non-Federal entity may charge to the Federal award only allowable costs incurred during the period of performance (except as described in §200.461 Publication and printing costs) and any costs incurred before the Federal awarding agency or pass-through entity made the Federal award that were authorized by the Federal awarding agency or pass-through entity.

[78 FR 78608, Dec. 26, 2013, as amended at 79 FR 75884, Dec. 19, 2014]

[↑ Back to Top](#)

PROPERTY STANDARDS

[↑ Back to Top](#)

§200.310 Insurance coverage.

The non-Federal entity must, at a minimum, provide the equivalent insurance coverage for real property and equipment acquired or improved with Federal funds as provided to property owned by the non-Federal entity. Federally-owned property need not be insured unless required by the terms and conditions of the Federal award.

[↑ Back to Top](#)

§200.311 Real property.

(a) *Title.* Subject to the obligations and conditions set forth in this section, title to real property acquired or improved under a Federal award will vest upon acquisition in the non-Federal entity.

(b) *Use.* Except as otherwise provided by Federal statutes or by the Federal awarding agency, real property will be used for the originally authorized purpose as long as needed for that purpose, during which time the non-Federal entity must not dispose of or encumber its title or other interests.

(c) *Disposition.* When real property is no longer needed for the originally authorized purpose, the non-Federal entity must obtain disposition instructions from the Federal awarding agency or pass-through entity. The instructions must provide for one of the following alternatives:

(1) Retain title after compensating the Federal awarding agency. The amount paid to the Federal awarding agency will be computed by applying the Federal awarding agency's percentage of participation in the cost of the original purchase (and costs of any improvements) to the fair market value of the property. However, in those situations where the non-Federal entity is disposing of real property acquired or improved with a Federal award and acquiring replacement real property under the same Federal award, the net proceeds from the disposition may be used as an offset to the cost of the replacement property.

(2) Sell the property and compensate the Federal awarding agency. The amount due to the Federal awarding agency will be calculated by applying the Federal awarding agency's percentage of participation in the cost of the original purchase (and cost of any improvements) to the proceeds of the sale after deduction of any actual and reasonable selling and fixing-up expenses. If the Federal award has not been closed out, the net proceeds from sale may be offset against the original cost of the property. When the non-Federal entity is directed to sell property, sales procedures must be followed that provide for competition to the extent practicable and result in the highest possible return.

(3) Transfer title to the Federal awarding agency or to a third party designated/approved by the Federal awarding agency. The non-Federal entity is entitled to be paid an amount calculated by applying the non-Federal entity's percentage of participation in the purchase of the real property (and cost of any improvements) to the current fair market value of the property.

[78 FR 78608, Dec. 26, 2013, as amended at 79 FR 75884, Dec. 19, 2014]

[↑ Back to Top](#)

§200.312 Federally-owned and exempt property.

(a) Title to federally-owned property remains vested in the Federal Government. The non-Federal entity must submit annually an inventory listing of federally-owned property in its custody to the Federal awarding agency. Upon completion of the Federal award or when the property is no longer needed, the non-Federal entity must report the property to the Federal awarding agency for further Federal agency utilization.

(b) If the Federal awarding agency has no further need for the property, it must declare the property excess and report it for disposal to the appropriate Federal disposal authority, unless the Federal awarding agency has statutory authority to dispose of the property by alternative methods (e.g., the authority provided by the Federal Technology Transfer Act (15 U.S.C. 3710 (i))) to donate research equipment to educational and non-profit organizations in accordance with Executive Order 12999, "Educational Technology: Ensuring Opportunity for All Children in the Next Century."). The Federal awarding agency must issue appropriate instructions to the non-Federal entity.

(c) Exempt federally-owned property means property acquired under a Federal award where the Federal awarding agency has chosen to vest title to the property to the non-Federal entity without further obligation to the Federal Government, based upon the explicit terms and

conditions of the Federal award. The Federal awarding agency may exercise this option when statutory authority exists. Absent statutory authority and specific terms and conditions of the Federal award, title to exempt federally-owned property acquired under the Federal award remains with the Federal Government.

[78 FR 78608, Dec. 26, 2013, as amended at 79 FR 75884, Dec. 19, 2014]

[Back to Top](#)

§200.313 Equipment.

See also §200.439 Equipment and other capital expenditures.

(a) *Title.* Subject to the obligations and conditions set forth in this section, title to equipment acquired under a Federal award will vest upon acquisition in the non-Federal entity. Unless a statute specifically authorizes the Federal agency to vest title in the non-Federal entity without further obligation to the Federal Government, and the Federal agency elects to do so, the title must be a conditional title. Title must vest in the non-Federal entity subject to the following conditions:

(1) Use the equipment for the authorized purposes of the project during the period of performance, or until the property is no longer needed for the purposes of the project.

(2) Not encumber the property without approval of the Federal awarding agency or pass-through entity.

(3) Use and dispose of the property in accordance with paragraphs (b), (c) and (e) of this section.

(b) A state must use, manage and dispose of equipment acquired under a Federal award by the state in accordance with state laws and procedures. Other non-Federal entities must follow paragraphs (c) through (e) of this section.

(c) *Use.* (1) Equipment must be used by the non-Federal entity in the program or project for which it was acquired as long as needed, whether or not the project or program continues to be supported by the Federal award, and the non-Federal entity must not encumber the property without prior approval of the Federal awarding agency. When no longer needed for the original program or project, the equipment may be used in other activities supported by the Federal awarding agency, in the following order of priority:

(i) Activities under a Federal award from the Federal awarding agency which funded the original program or project, then

(ii) Activities under Federal awards from other Federal awarding agencies. This includes consolidated equipment for information technology systems.

(2) During the time that equipment is used on the project or program for which it was acquired, the non-Federal entity must also make equipment available for use on other projects or programs currently or previously supported by the Federal Government, provided that such use will not interfere with the work on the projects or program for which it was originally acquired. First preference for other use must be given to other programs or projects supported by Federal awarding agency that financed the equipment and second preference must be given to programs or projects under Federal awards from other Federal awarding agencies. Use for non-federally-funded programs or projects is also permissible. User fees should be considered if appropriate.

(3) Notwithstanding the encouragement in §200.307 Program income to earn program income, the non-Federal entity must not use equipment acquired with the Federal award to provide services for a fee that is less than private companies charge for equivalent services unless specifically authorized by Federal statute for as long as the Federal Government retains an interest in the equipment.

(4) When acquiring replacement equipment, the non-Federal entity may use the equipment to be replaced as a trade-in or sell the property and use the proceeds to offset the cost of the replacement property.

(d) *Management requirements.* Procedures for managing equipment (including replacement equipment), whether acquired in whole or in part under a Federal award, until disposition takes place will, as a minimum, meet the following requirements:

(1) Property records must be maintained that include a description of the property, a serial number or other identification number, the source of funding for the property (including the FAIN), who holds title, the acquisition date, and cost of the property, percentage of Federal participation in the project costs for the Federal award under which the property was acquired, the location, use and condition of the property, and any ultimate disposition data including the date of disposal and sale price of the property.

(2) A physical inventory of the property must be taken and the results reconciled with the property records at least once every two years.

(3) A control system must be developed to ensure adequate safeguards to prevent loss, damage, or theft of the property. Any loss, damage, or theft must be investigated.

(4) Adequate maintenance procedures must be developed to keep the property in good condition.

(5) If the non-Federal entity is authorized or required to sell the property, proper sales procedures must be established to ensure the highest possible return.

(e) *Disposition.* When original or replacement equipment acquired under a Federal award is no longer needed for the original project or program or for other activities currently or previously supported by a Federal awarding agency, except as otherwise provided in Federal statutes, regulations, or Federal awarding agency disposition instructions, the non-Federal entity must request disposition instructions from the Federal awarding agency if required by the terms and conditions of the Federal award. Disposition of the equipment will be made as follows, in accordance with Federal awarding agency disposition instructions:

(1) Items of equipment with a current per unit fair market value of \$5,000 or less may be retained, sold or otherwise disposed of with no further obligation to the Federal awarding agency.

(2) Except as provided in §200.312 Federally-owned and exempt property, paragraph (b), or if the Federal awarding agency fails to provide requested disposition instructions within 120 days, items of equipment with a current per-unit fair-market value in excess of \$5,000 may be retained by the non-Federal entity or sold. The Federal awarding agency is entitled to an amount calculated by multiplying the current market value or proceeds from sale by the Federal awarding agency's percentage of participation in the cost of the original purchase. If the equipment is

sold, the Federal awarding agency may permit the non-Federal entity to deduct and retain from the Federal share \$500 or ten percent of the proceeds, whichever is less, for its selling and handling expenses.

(3) The non-Federal entity may transfer title to the property to the Federal Government or to an eligible third party provided that, in such cases, the non-Federal entity must be entitled to compensation for its attributable percentage of the current fair market value of the property.

(4) In cases where a non-Federal entity fails to take appropriate disposition actions, the Federal awarding agency may direct the non-Federal entity to take disposition actions.

[78 FR 78608, Dec. 26, 2013, as amended at 79 FR 75884, Dec. 19, 2014]

[↑ Back to Top](#)

§200.314 Supplies.

See also §200.453 Materials and supplies costs, including costs of computing devices.

(a) Title to supplies will vest in the non-Federal entity upon acquisition. If there is a residual inventory of unused supplies exceeding \$5,000 in total aggregate value upon termination or completion of the project or program and the supplies are not needed for any other Federal award, the non-Federal entity must retain the supplies for use on other activities or sell them, but must, in either case, compensate the Federal Government for its share. The amount of compensation must be computed in the same manner as for equipment. See §200.313 Equipment, paragraph (e)(2) for the calculation methodology.

(b) As long as the Federal Government retains an interest in the supplies, the non-Federal entity must not use supplies acquired under a Federal award to provide services to other organizations for a fee that is less than private companies charge for equivalent services, unless specifically authorized by Federal statute.

[↑ Back to Top](#)

§200.315 Intangible property.

(a) Title to intangible property (see §200.59 Intangible property) acquired under a Federal award vests upon acquisition in the non-Federal entity. The non-Federal entity must use that property for the originally-authorized purpose, and must not encumber the property without approval of the Federal awarding agency. When no longer needed for the originally authorized purpose, disposition of the intangible property must occur in accordance with the provisions in §200.313 Equipment paragraph (e).

(b) The non-Federal entity may copyright any work that is subject to copyright and was developed, or for which ownership was acquired, under a Federal award. The Federal awarding agency reserves a royalty-free, nonexclusive and irrevocable right to reproduce, publish, or otherwise use the work for Federal purposes, and to authorize others to do so.

(c) The non-Federal entity is subject to applicable regulations governing patents and inventions, including governmentwide regulations issued by the Department of Commerce at 37 CFR Part 401, "Rights to Inventions Made by Nonprofit Organizations and Small Business Firms Under Government Awards, Contracts and Cooperative Agreements."

(d) The Federal Government has the right to:

- (1) Obtain, reproduce, publish, or otherwise use the data produced under a Federal award; and
 - (2) Authorize others to receive, reproduce, publish, or otherwise use such data for Federal purposes.
- (e) Freedom of Information Act (FOIA).

(1) In response to a Freedom of Information Act (FOIA) request for research data relating to published research findings produced under a Federal award that were used by the Federal Government in developing an agency action that has the force and effect of law, the Federal awarding agency must request, and the non-Federal entity must provide, within a reasonable time, the research data so that they can be made available to the public through the procedures established under the FOIA. If the Federal awarding agency obtains the research data solely in response to a FOIA request, the Federal awarding agency may charge the requester a reasonable fee equaling the full incremental cost of obtaining the research data. This fee should reflect costs incurred by the Federal agency and the non-Federal entity. This fee is in addition to any fees the Federal awarding agency may assess under the FOIA (5 U.S.C. 552(a)(4)(A)).

(2) Published research findings means when:

(i) Research findings are published in a peer-reviewed scientific or technical journal; or

(ii) A Federal agency publicly and officially cites the research findings in support of an agency action that has the force and effect of law. "Used by the Federal Government in developing an agency action that has the force and effect of law" is defined as when an agency publicly and officially cites the research findings in support of an agency action that has the force and effect of law.

(3) Research data means the recorded factual material commonly accepted in the scientific community as necessary to validate research findings, but not any of the following: preliminary analyses, drafts of scientific papers, plans for future research, peer reviews, or communications with colleagues. This "recorded" material excludes physical objects (e.g., laboratory samples). Research data also do not include:

(i) Trade secrets, commercial information, materials necessary to be held confidential by a researcher until they are published, or similar information which is protected under law; and

(ii) Personnel and medical information and similar information the disclosure of which would constitute a clearly unwarranted invasion of personal privacy, such as information that could be used to identify a particular person in a research study.

[78 FR 78608, Dec. 26, 2013, as amended at 79 FR 75884, Dec. 19, 2014]

[↑ Back to Top](#)

§200.316 Property trust relationship.

Real property, equipment, and intangible property, that are acquired or improved with a Federal award must be held in trust by the non-Federal entity as trustee for the beneficiaries of the project or program under which the property was acquired or improved. The Federal awarding agency may require the non-Federal entity to record liens or other appropriate notices of record to indicate that personal or real property has been acquired or improved with a Federal award and that use and disposition conditions apply to the property.

[↑ Back to Top](#)

PROCUREMENT STANDARDS

[↑ Back to Top](#)

§200.317 Procurements by states.

When procuring property and services under a Federal award, a state must follow the same policies and procedures it uses for procurements from its non-Federal funds. The state will comply with §200.322 Procurement of recovered *materials* and ensure that every purchase order or other contract includes any clauses required by section §200.326 Contract provisions. All other non-Federal entities, including subrecipients of a state, will follow §§200.318 General procurement standards through 200.326 Contract provisions.

[↑ Back to Top](#)

§200.318 General procurement standards.

(a) The non-Federal entity must use its own documented procurement procedures which reflect applicable State, local, and tribal laws and regulations, provided that the procurements conform to applicable Federal law and the standards identified in this part.

(b) Non-Federal entities must maintain oversight to ensure that contractors perform in accordance with the terms, conditions, and specifications of their contracts or purchase orders.

(c)(1) The non-Federal entity must maintain written standards of conduct covering conflicts of interest and governing the actions of its employees engaged in the selection, award and administration of contracts. No employee, officer, or agent may participate in the selection, award, or administration of a contract supported by a Federal award if he or she has a real or apparent conflict of interest. Such a conflict of interest would arise when the employee, officer, or agent, any member of his or her immediate family, his or her partner, or an organization which employs or is about to employ any of the parties indicated herein, has a financial or other interest in or a tangible personal benefit from a firm considered for a contract. The officers, employees, and agents of the non-Federal entity may neither solicit nor accept gratuities, favors, or anything of monetary value from contractors or parties to subcontracts. However, non-Federal entities may set standards for situations in which the financial interest is not substantial or the gift is an unsolicited item of nominal value. The standards of conduct must provide for disciplinary actions to be applied for violations of such standards by officers, employees, or agents of the non-Federal entity.

(2) If the non-Federal entity has a parent, affiliate, or subsidiary organization that is not a state, local government, or Indian tribe, the non-Federal entity must also maintain written standards of conduct covering organizational conflicts of interest. Organizational conflicts of interest means that because of relationships with a parent company, affiliate, or subsidiary organization, the non-Federal entity is unable or appears to be unable to be impartial in conducting a procurement action involving a related organization.

(d) The non-Federal entity's procedures must avoid acquisition of unnecessary or duplicative items. Consideration should be given to consolidating or breaking out procurements to obtain a more economical purchase. Where appropriate, an analysis will be made of lease versus purchase alternatives, and any other appropriate analysis to determine the most economical approach.

(e) To foster greater economy and efficiency, and in accordance with efforts to promote cost-effective use of shared services across the Federal Government, the non-Federal entity is encouraged to enter into state and local intergovernmental agreements or inter-entity agreements where appropriate for procurement or use of common or shared goods and services.

(f) The non-Federal entity is encouraged to use Federal excess and surplus property in lieu of purchasing new equipment and property whenever such use is feasible and reduces project costs.

(g) The non-Federal entity is encouraged to use value engineering clauses in contracts for construction projects of sufficient size to offer reasonable opportunities for cost reductions. Value engineering is a systematic and creative analysis of each contract item or task to ensure that its essential function is provided at the overall lower cost.

(h) The non-Federal entity must award contracts only to responsible contractors possessing the ability to perform successfully under the terms and conditions of a proposed procurement. Consideration will be given to such matters as contractor integrity, compliance with public policy, record of past performance, and financial and technical resources. See also §200.212 Suspension and debarment.

(i) The non-Federal entity must maintain records sufficient to detail the history of procurement. These records will include, but are not necessarily limited to the following: rationale for the method of procurement, selection of contract type, contractor selection or rejection, and the basis for the contract price.

(j)(1) The non-Federal entity may use a time and materials type contract only after a determination that no other contract is suitable and if the contract includes a ceiling price that the contractor exceeds at its own risk. Time and materials type contract means a contract whose cost to a non-Federal entity is the sum of:

(i) The actual cost of materials; and

(ii) Direct labor hours charged at fixed hourly rates that reflect wages, general and administrative expenses, and profit.

(2) Since this formula generates an open-ended contract price, a time-and-materials contract provides no positive profit incentive to the contractor for cost control or labor efficiency. Therefore, each contract must set a ceiling price that the contractor exceeds at its own risk. Further, the non-Federal entity awarding such a contract must assert a high degree of oversight in order to obtain reasonable assurance that the contractor is using efficient methods and effective cost controls.

(k) The non-Federal entity alone must be responsible, in accordance with good administrative practice and sound business judgment, for the settlement of all contractual and administrative issues arising out of procurements. These issues include, but are not limited to, source evaluation, protests, disputes, and claims. These standards do not relieve the non-Federal entity of any contractual responsibilities under its

contracts. The Federal awarding agency will not substitute its judgment for that of the non-Federal entity unless the matter is primarily a Federal concern. Violations of law will be referred to the local, state, or Federal authority having proper jurisdiction.

[↑ Back to Top](#)

§200.319 Competition.

(a) All procurement transactions must be conducted in a manner providing full and open competition consistent with the standards of this section. In order to ensure objective contractor performance and eliminate unfair competitive advantage, contractors that develop or draft specifications, requirements, statements of work, or invitations for bids or requests for proposals must be excluded from competing for such procurements. Some of the situations considered to be restrictive of competition include but are not limited to:

(1) Placing unreasonable requirements on firms in order for them to qualify to do business;

(2) Requiring unnecessary experience and excessive bonding;

(3) Noncompetitive pricing practices between firms or between affiliated companies;

(4) Noncompetitive contracts to consultants that are on retainer contracts;

(5) Organizational conflicts of interest;

(6) Specifying only a "brand name" product instead of allowing "an equal" product to be offered and describing the performance or other relevant requirements of the procurement; and

(7) Any arbitrary action in the procurement process.

(b) The non-Federal entity must conduct procurements in a manner that prohibits the use of statutorily or administratively imposed state, local, or tribal geographical preferences in the evaluation of bids or proposals, except in those cases where applicable Federal statutes expressly mandate or encourage geographic preference. Nothing in this section preempts state licensing laws. When contracting for architectural and engineering (A/E) services, geographic location may be a selection criterion provided its application leaves an appropriate number of qualified firms, given the nature and size of the project, to compete for the contract.

(c) The non-Federal entity must have written procedures for procurement transactions. These procedures must ensure that all solicitations:

(1) Incorporate a clear and accurate description of the technical requirements for the material, product, or service to be procured. Such description must not, in competitive procurements, contain features which unduly restrict competition. The description may include a statement of the qualitative nature of the material, product or service to be procured and, when necessary, must set forth those minimum essential characteristics and standards to which it must conform if it is to satisfy its intended use. Detailed product specifications should be avoided if at all possible. When it is impractical or uneconomical to make a clear and accurate description of the technical requirements, a "brand name or equivalent" description may be used as a means to define the performance or other salient requirements of procurement. The specific features of the named brand which must be met by offers must be clearly stated; and

(2) Identify all requirements which the offerors must fulfill and all other factors to be used in evaluating bids or proposals.

(d) The non-Federal entity must ensure that all prequalified lists of persons, firms, or products which are used in acquiring goods and services are current and include enough qualified sources to ensure maximum open and free competition. Also, the non-Federal entity must not preclude potential bidders from qualifying during the solicitation period.

[78 FR 78608, Dec. 26, 2013, as amended at 79 FR 75885, Dec. 19, 2014]

[↑ Back to Top](#)

§200.320 Methods of procurement to be followed.

The non-Federal entity must use one of the following methods of procurement.

(a) Procurement by micro-purchases. Procurement by micro-purchase is the acquisition of supplies or services, the aggregate dollar amount of which does not exceed the micro-purchase threshold (§200.67 Micro-purchase). To the extent practicable, the non-Federal entity must distribute micro-purchases equitably among qualified suppliers. Micro-purchases may be awarded without soliciting competitive quotations if the non-Federal entity considers the price to be reasonable.

(b) Procurement by small purchase procedures. Small purchase procedures are those relatively simple and informal procurement methods for securing services, supplies, or other property that do not cost more than the Simplified Acquisition Threshold. If small purchase procedures are used, price or rate quotations must be obtained from an adequate number of qualified sources.

(c) Procurement by sealed bids (formal advertising). Bids are publicly solicited and a firm fixed price contract (lump sum or unit price) is awarded to the responsible bidder whose bid, conforming with all the material terms and conditions of the invitation for bids, is the lowest in price. The sealed bid method is the preferred method for procuring construction, if the conditions in paragraph (c)(1) of this section apply.

(1) In order for sealed bidding to be feasible, the following conditions should be present:

(i) A complete, adequate, and realistic specification or purchase description is available;

(ii) Two or more responsible bidders are willing and able to compete effectively for the business; and

(iii) The procurement lends itself to a firm fixed price contract and the selection of the successful bidder can be made principally on the basis of price.

(2) If sealed bids are used, the following requirements apply:

(i) Bids must be solicited from an adequate number of known suppliers, providing them sufficient response time prior to the date set for opening the bids, for state, local, and tribal governments, the invitation for bids must be publically advertised;

(ii) The invitation for bids, which will include any specifications and pertinent attachments, must define the items or services in order for the bidder to properly respond;

(iii) All bids will be opened at the time and place prescribed in the invitation for bids, and for local and tribal governments, the bids must be opened publicly;

(iv) A firm fixed price contract award will be made in writing to the lowest responsive and responsible bidder. Where specified in bidding documents, factors such as discounts, transportation cost, and life cycle costs must be considered in determining which bid is lowest. Payment discounts will only be used to determine the low bid when prior experience indicates that such discounts are usually taken advantage of; and

(v) Any or all bids may be rejected if there is a sound documented reason.

(d) Procurement by competitive proposals. The technique of competitive proposals is normally conducted with more than one source submitting an offer, and either a fixed price or cost-reimbursement type contract is awarded. It is generally used when conditions are not appropriate for the use of sealed bids. If this method is used, the following requirements apply:

(1) Requests for proposals must be publicized and identify all evaluation factors and their relative importance. Any response to publicized requests for proposals must be considered to the maximum extent practical;

(2) Proposals must be solicited from an adequate number of qualified sources;

(3) The non-Federal entity must have a written method for conducting technical evaluations of the proposals received and for selecting recipients;

(4) Contracts must be awarded to the responsible firm whose proposal is most advantageous to the program, with price and other factors considered; and

(5) The non-Federal entity may use competitive proposal procedures for qualifications-based procurement of architectural/engineering (A/E) professional services whereby competitors' qualifications are evaluated and the most qualified competitor is selected, subject to negotiation of fair and reasonable compensation. The method, where price is not used as a selection factor, can only be used in procurement of A/E professional services. It cannot be used to purchase other types of services though A/E firms are a potential source to perform the proposed effort.

(e) [Reserved]

(f) Procurement by noncompetitive proposals. Procurement by noncompetitive proposals is procurement through solicitation of a proposal from only one source and may be used only when one or more of the following circumstances apply:

(1) The item is available only from a single source;

(2) The public exigency or emergency for the requirement will not permit a delay resulting from competitive solicitation;

(3) The Federal awarding agency or pass-through entity expressly authorizes noncompetitive proposals in response to a written request from the non-Federal entity; or

(4) After solicitation of a number of sources, competition is determined inadequate.

[78 FR 78608, Dec. 26, 2013, as amended at 79 FR 75885, Dec. 19, 2014]

[↑ Back to Top](#)

§200.321 Contracting with small and minority businesses, women's business enterprises, and labor surplus area firms.

(a) The non-Federal entity must take all necessary affirmative steps to assure that minority businesses, women's business enterprises, and labor surplus area firms are used when possible.

(b) Affirmative steps must include:

(1) Placing qualified small and minority businesses and women's business enterprises on solicitation lists;

(2) Assuring that small and minority businesses, and women's business enterprises are solicited whenever they are potential sources;

(3) Dividing total requirements, when economically feasible, into smaller tasks or quantities to permit maximum participation by small and minority businesses, and women's business enterprises;

(4) Establishing delivery schedules, where the requirement permits, which encourage participation by small and minority businesses, and women's business enterprises;

(5) Using the services and assistance, as appropriate, of such organizations as the Small Business Administration and the Minority Business Development Agency of the Department of Commerce; and

(6) Requiring the prime contractor, if subcontracts are to be let, to take the affirmative steps listed in paragraphs (1) through (5) of this section.

[↑ Back to Top](#)

§200.322 Procurement of recovered materials.

A non-Federal entity that is a state agency or agency of a political subdivision of a state and its contractors must comply with section 6002 of the Solid Waste Disposal Act, as amended by the Resource Conservation and Recovery Act. The requirements of Section 6002 include procuring only items designated in guidelines of the Environmental Protection Agency (EPA) at 40 CFR part 247 that contain the highest percentage of recovered materials practicable, consistent with maintaining a satisfactory level of competition, where the purchase price of the item exceeds \$10,000 or the value of the quantity acquired during the preceding fiscal year exceeded \$10,000; procuring solid waste

management services in a manner that maximizes energy and resource recovery; and establishing an affirmative procurement program for procurement of recovered materials identified in the EPA guidelines.

[78 FR 78608, Dec. 26, 2013, as amended at 79 FR 75885, Dec. 19, 2014]

[↑ Back to Top](#)

§200.323 Contract cost and price.

(a) The non-Federal entity must perform a cost or price analysis in connection with every procurement action in excess of the Simplified Acquisition Threshold including contract modifications. The method and degree of analysis is dependent on the facts surrounding the particular procurement situation, but as a starting point, the non-Federal entity must make independent estimates before receiving bids or proposals.

(b) The non-Federal entity must negotiate profit as a separate element of the price for each contract in which there is no price competition and in all cases where cost analysis is performed. To establish a fair and reasonable profit, consideration must be given to the complexity of the work to be performed, the risk borne by the contractor, the contractor's investment, the amount of subcontracting, the quality of its record of past performance, and industry profit rates in the surrounding geographical area for similar work.

(c) Costs or prices based on estimated costs for contracts under the Federal award are allowable only to the extent that costs incurred or cost estimates included in negotiated prices would be allowable for the non-Federal entity under Subpart E—Cost Principles of this part. The non-Federal entity may reference its own cost principles that comply with the Federal cost principles.

(d) The cost plus a percentage of cost and percentage of construction cost methods of contracting must not be used.

[↑ Back to Top](#)

§200.324 Federal awarding agency or pass-through entity review.

(a) The non-Federal entity must make available, upon request of the Federal awarding agency or pass-through entity, technical specifications on proposed procurements where the Federal awarding agency or pass-through entity believes such review is needed to ensure that the item or service specified is the one being proposed for acquisition. This review generally will take place prior to the time the specification is incorporated into a solicitation document. However, if the non-Federal entity desires to have the review accomplished after a solicitation has been developed, the Federal awarding agency or pass-through entity may still review the specifications, with such review usually limited to the technical aspects of the proposed purchase.

(b) The non-Federal entity must make available upon request, for the Federal awarding agency or pass-through entity pre-procurement review, procurement documents, such as requests for proposals or invitations for bids, or independent cost estimates, when:

(1) The non-Federal entity's procurement procedures or operation fails to comply with the procurement standards in this part;

(2) The procurement is expected to exceed the Simplified Acquisition Threshold and is to be awarded without competition or only one bid or offer is received in response to a solicitation;

(3) The procurement, which is expected to exceed the Simplified Acquisition Threshold, specifies a "brand name" product;

(4) The proposed contract is more than the Simplified Acquisition Threshold and is to be awarded to other than the apparent low bidder under a sealed bid procurement; or

(5) A proposed contract modification changes the scope of a contract or increases the contract amount by more than the Simplified Acquisition Threshold.

(c) The non-Federal entity is exempt from the pre-procurement review in paragraph (b) of this section if the Federal awarding agency or pass-through entity determines that its procurement systems comply with the standards of this part.

(1) The non-Federal entity may request that its procurement system be reviewed by the Federal awarding agency or pass-through entity to determine whether its system meets these standards in order for its system to be certified. Generally, these reviews must occur where there is continuous high-dollar funding, and third party contracts are awarded on a regular basis;

(2) The non-Federal entity may self-certify its procurement system. Such self-certification must not limit the Federal awarding agency's right to survey the system. Under a self-certification procedure, the Federal awarding agency may rely on written assurances from the non-Federal entity that it is complying with these standards. The non-Federal entity must cite specific policies, procedures, regulations, or standards as being in compliance with these requirements and have its system available for review.

[↑ Back to Top](#)

§200.325 Bonding requirements.

For construction or facility improvement contracts or subcontracts exceeding the Simplified Acquisition Threshold, the Federal awarding agency or pass-through entity may accept the bonding policy and requirements of the non-Federal entity provided that the Federal awarding agency or pass-through entity has made a determination that the Federal interest is adequately protected. If such a determination has not been made, the minimum requirements must be as follows:

(a) A bid guarantee from each bidder equivalent to five percent of the bid price. The "bid guarantee" must consist of a firm commitment such as a bid bond, certified check, or other negotiable instrument accompanying a bid as assurance that the bidder will, upon acceptance of the bid, execute such contractual documents as may be required within the time specified.

(b) A performance bond on the part of the contractor for 100 percent of the contract price. A "performance bond" is one executed in connection with a contract to secure fulfillment of all the contractor's obligations under such contract.

(c) A payment bond on the part of the contractor for 100 percent of the contract price. A "payment bond" is one executed in connection with a contract to assure payment as required by law of all persons supplying labor and material in the execution of the work provided for in the contract.

[↑ Back to Top](#)

§200.326 Contract provisions.

The non-Federal entity's contracts must contain the applicable provisions described in Appendix II to Part 200—Contract Provisions for non-Federal Entity Contracts Under Federal Awards.

[↑ Back to Top](#)

PERFORMANCE AND FINANCIAL MONITORING AND REPORTING

[↑ Back to Top](#)

§200.327 Financial reporting.

Unless otherwise approved by OMB, the Federal awarding agency may solicit only the standard, OMB-approved governmentwide data elements for collection of financial information (at time of publication the Federal Financial Report or such future collections as may be approved by OMB and listed on the OMB Web site). This information must be collected with the frequency required by the terms and conditions of the Federal award, but no less frequently than annually nor more frequently than quarterly except in unusual circumstances, for example where more frequent reporting is necessary for the effective monitoring of the Federal award or could significantly affect program outcomes, and preferably in coordination with performance reporting.

[↑ Back to Top](#)

200.328 Monitoring and reporting program performance.

(a) *Monitoring by the non-Federal entity.* The non-Federal entity is responsible for oversight of the operations of the Federal award supported activities. The non-Federal entity must monitor its activities under Federal awards to assure compliance with applicable Federal requirements and performance expectations are being achieved. Monitoring by the non-Federal entity must cover each program, function or activity. See also §200.331 Requirements for pass-through entities.

(b) *Non-construction performance reports.* The Federal awarding agency must use standard, OMB-approved data elements for collection of performance information (including performance progress reports, Research Performance Progress Report, or such future collections as may be approved by OMB and listed on the OMB Web site).

(1) The non-Federal entity must submit performance reports at the interval required by the Federal awarding agency or pass-through entity to best inform improvements in program outcomes and productivity. Intervals must be no less frequent than annually nor more frequent than quarterly except in unusual circumstances, for example where more frequent reporting is necessary for the effective monitoring of the Federal award or could significantly affect program outcomes. Annual reports must be due 90 calendar days after the reporting period; quarterly or semiannual reports must be due 30 calendar days after the reporting period. Alternatively, the Federal awarding agency or pass-through entity may require annual reports before the anniversary dates of multiple year Federal awards. The final performance report will be due 90 calendar days after the period of performance end date. If a justified request is submitted by a non-Federal entity, the Federal agency may extend the due date for any performance report.

(2) The non-Federal entity must submit performance reports using OMB-approved governmentwide standard information collections when providing performance information. As appropriate in accordance with above mentioned information collections, these reports will contain, for each Federal award, brief information on the following unless other collections are approved by OMB:

(i) A comparison of actual accomplishments to the objectives of the Federal award established for the period. Where the accomplishments of the Federal award can be quantified, a computation of the cost (for example, related to units of accomplishment) may be required if that information will be useful. Where performance trend data and analysis would be informative to the Federal awarding agency program, the Federal awarding agency should include this as a performance reporting requirement.

(ii) The reasons why established goals were not met, if appropriate.

(iii) Additional pertinent information including, when appropriate, analysis and explanation of cost overruns or high unit costs.

(c) *Construction performance reports.* For the most part, onsite technical inspections and certified percentage of completion data are relied on heavily by Federal awarding agencies and pass-through entities to monitor progress under Federal awards and subawards for construction. The Federal awarding agency may require additional performance reports only when considered necessary.

(d) *Significant developments.* Events may occur between the scheduled performance reporting dates that have significant impact upon the supported activity. In such cases, the non-Federal entity must inform the Federal awarding agency or pass-through entity as soon as the following types of conditions become known:

(1) Problems, delays, or adverse conditions which will materially impair the ability to meet the objective of the Federal award. This disclosure must include a statement of the action taken, or contemplated, and any assistance needed to resolve the situation.

(2) Favorable developments which enable meeting time schedules and objectives sooner or at less cost than anticipated or producing more or different beneficial results than originally planned.

(e) The Federal awarding agency may make site visits as warranted by program needs.

(f) The Federal awarding agency may waive any performance report required by this part if not needed.

[↑ Back to Top](#)

§200.329 Reporting on real property.

The Federal awarding agency or pass-through entity must require a non-Federal entity to submit reports at least annually on the status of real property in which the Federal Government retains an interest, unless the Federal interest in the real property extends 15 years or longer. In those instances where the Federal interest attached is for a period of 15 years or more, the Federal awarding agency or pass-through entity, at its option, may require the non-Federal entity to report at various multi-year frequencies (e.g., every two years or every three years, not to

exceed a five-year reporting period; or a Federal awarding agency or pass-through entity may require annual reporting for the first three years of a Federal award and thereafter require reporting every five years).

[↑ Back to Top](#)

SUBRECIPIENT MONITORING AND MANAGEMENT

[↑ Back to Top](#)

§200.330 Subrecipient and contractor determinations.

The non-Federal entity may concurrently receive Federal awards as a recipient, a subrecipient, and a contractor, depending on the substance of its agreements with Federal awarding agencies and pass-through entities. Therefore, a pass-through entity must make case-by-case determinations whether each agreement it makes for the disbursement of Federal program funds casts the party receiving the funds in the role of a subrecipient or a contractor. The Federal awarding agency may supply and require recipients to comply with additional guidance to support these determinations provided such guidance does not conflict with this section.

(a) *Subrecipients.* A subaward is for the purpose of carrying out a portion of a Federal award and creates a Federal assistance relationship with the subrecipient. See §200.92 Subaward. Characteristics which support the classification of the non-Federal entity as a subrecipient include when the non-Federal entity:

- (1) Determines who is eligible to receive what Federal assistance;
- (2) Has its performance measured in relation to whether objectives of a Federal program were met;
- (3) Has responsibility for programmatic decision making;
- (4) Is responsible for adherence to applicable Federal program requirements specified in the Federal award; and
- (5) In accordance with its agreement, uses the Federal funds to carry out a program for a public purpose specified in authorizing statute, as opposed to providing goods or services for the benefit of the pass-through entity.

(b) *Contractors.* A contract is for the purpose of obtaining goods and services for the non-Federal entity's own use and creates a procurement relationship with the contractor. See §200.22 Contract. Characteristics indicative of a procurement relationship between the non-Federal entity and a contractor are when the non-Federal entity receiving the Federal funds:

- (1) Provides the goods and services within normal business operations;
- (2) Provides similar goods or services to many different purchasers;
- (3) Normally operates in a competitive environment;
- (4) Provides goods or services that are ancillary to the operation of the Federal program; and
- (5) Is not subject to compliance requirements of the Federal program as a result of the agreement, though similar requirements may apply for other reasons.

(c) *Use of judgment in making determination.* In determining whether an agreement between a pass-through entity and another non-Federal entity casts the latter as a subrecipient or a contractor, the substance of the relationship is more important than the form of the agreement. All of the characteristics listed above may not be present in all cases, and the pass-through entity must use judgment in classifying each agreement as a subaward or a procurement contract.

[↑ Back to Top](#)

§200.331 Requirements for pass-through entities.

All pass-through entities must:

(a) Ensure that every subaward is clearly identified to the subrecipient as a subaward and includes the following information at the time of the subaward and if any of these data elements change, include the changes in subsequent subaward modification. When some of this information is not available, the pass-through entity must provide the best information available to describe the Federal award and subaward. Required information includes:

- (1) Federal Award Identification.
 - (i) Subrecipient name (which must match the name associated with its unique entity identifier);
 - (ii) Subrecipient's unique entity identifier;
 - (iii) Federal Award Identification Number (FAIN);
 - (iv) Federal Award Date (see §200.39 Federal award date);
 - (v) Subaward Period of Performance Start and End Date;
 - (vi) Amount of Federal Funds Obligated by this action;
 - (vii) Total Amount of Federal Funds Obligated to the subrecipient;
 - (viii) Total Amount of the Federal Award;
 - (ix) Federal award project description, as required to be responsive to the Federal Funding Accountability and Transparency Act (FFATA);
 - (x) Name of Federal awarding agency, pass-through entity, and contact information for awarding official,

(xi) CFDA Number and Name; the pass-through entity must identify the dollar amount made available under each Federal award and the CFDA number at time of disbursement;

(xii) Identification of whether the award is R&D; and

(xiii) Indirect cost rate for the Federal award (including if the de minimis rate is charged per §200.414 Indirect (F&A) costs).

(2) All requirements imposed by the pass-through entity on the subrecipient so that the Federal award is used in accordance with Federal statutes, regulations and the terms and conditions of the Federal award.

(3) Any additional requirements that the pass-through entity imposes on the subrecipient in order for the pass-through entity to meet its own responsibility to the Federal awarding agency including identification of any required financial and performance reports;

(4) An approved federally recognized indirect cost rate negotiated between the subrecipient and the Federal Government or, if no such rate exists, either a rate negotiated between the pass-through entity and the subrecipient (in compliance with this part), or a de minimis indirect cost rate as defined in §200.414 Indirect (F&A) costs, paragraph (f) of this part.

(5) A requirement that the subrecipient permit the pass-through entity and auditors to have access to the subrecipient's records and financial statements as necessary for the pass-through entity to meet the requirements of this part; and

(6) Appropriate terms and conditions concerning closeout of the subaward.

(b) Evaluate each subrecipient's risk of noncompliance with Federal statutes, regulations, and the terms and conditions of the subaward for purposes of determining the appropriate subrecipient monitoring described in paragraphs (d) and (e) of this section, which may include consideration of such factors as:

(1) The subrecipient's prior experience with the same or similar subawards;

(2) The results of previous audits including whether or not the subrecipient receives a Single Audit in accordance with Subpart F—Audit Requirements of this part, and the extent to which the same or similar subaward has been audited as a major program;

(3) Whether the subrecipient has new personnel or new or substantially changed systems; and

(4) The extent and results of Federal awarding agency monitoring (e.g., if the subrecipient also receives Federal awards directly from a Federal awarding agency).

(c) Consider imposing specific subaward conditions upon a subrecipient if appropriate as described in §200.207 Specific conditions.

(d) Monitor the activities of the subrecipient as necessary to ensure that the subaward is used for authorized purposes, in compliance with Federal statutes, regulations, and the terms and conditions of the subaward; and that subaward performance goals are achieved. Pass-through entity monitoring of the subrecipient must include:

(1) Reviewing financial and performance reports required by the pass-through entity.

(2) Following-up and ensuring that the subrecipient takes timely and appropriate action on all deficiencies pertaining to the Federal award provided to the subrecipient from the pass-through entity detected through audits, on-site reviews, and other means.

(3) Issuing a management decision for audit findings pertaining to the Federal award provided to the subrecipient from the pass-through entity as required by §200.521 Management decision.

(e) Depending upon the pass-through entity's assessment of risk posed by the subrecipient (as described in paragraph (b) of this section), the following monitoring tools may be useful for the pass-through entity to ensure proper accountability and compliance with program requirements and achievement of performance goals:

(1) Providing subrecipients with training and technical assistance on program-related matters; and

(2) Performing on-site reviews of the subrecipient's program operations;

(3) Arranging for agreed-upon-procedures engagements as described in §200.425 Audit services.

(f) Verify that every subrecipient is audited as required by Subpart F—Audit Requirements of this part when it is expected that the subrecipient's Federal awards expended during the respective fiscal year equaled or exceeded the threshold set forth in §200.501 Audit requirements.

(g) Consider whether the results of the subrecipient's audits, on-site reviews, or other monitoring indicate conditions that necessitate adjustments to the pass-through entity's own records.

(h) Consider taking enforcement action against noncompliant subrecipients as described in §200.338 Remedies for noncompliance of this part and in program regulations.

[78 FR 78608, Dec. 26, 2013, as amended at 79 FR 75885, Dec. 19, 2014]

[↑ Back to Top](#)

§200.332 Fixed amount subawards.

With prior written approval from the Federal awarding agency, a pass-through entity may provide subawards based on fixed amounts up to the Simplified Acquisition Threshold, provided that the subawards meet the requirements for fixed amount awards in §200.201 Use of grant agreements (including fixed amount awards), cooperative agreements, and contracts.

[↑ Back to Top](#)

RECORD RETENTION AND ACCESS

[↑ Back to Top](#)

§200.333 Retention requirements for records.

Financial records, supporting documents, statistical records, and all other non-Federal entity records pertinent to a Federal award must be retained for a period of three years from the date of submission of the final expenditure report or, for Federal awards that are renewed quarterly or annually, from the date of the submission of the quarterly or annual financial report, respectively, as reported to the Federal awarding agency or pass-through entity in the case of a subrecipient. Federal awarding agencies and pass-through entities must not impose any other record retention requirements upon non-Federal entities. The only exceptions are the following:

(a) If any litigation, claim, or audit is started before the expiration of the 3-year period, the records must be retained until all litigation, claims, or audit findings involving the records have been resolved and final action taken.

(b) When the non-Federal entity is notified in writing by the Federal awarding agency, cognizant agency for audit, oversight agency for audit, cognizant agency for indirect costs, or pass-through entity to extend the retention period.

(c) Records for real property and equipment acquired with Federal funds must be retained for 3 years after final disposition.

(d) When records are transferred to or maintained by the Federal awarding agency or pass-through entity, the 3-year retention requirement is not applicable to the non-Federal entity.

(e) Records for program income transactions after the period of performance. In some cases recipients must report program income after the period of performance. Where there is such a requirement, the retention period for the records pertaining to the earning of the program income starts from the end of the non-Federal entity's fiscal year in which the program income is earned.

(f) Indirect cost rate proposals and cost allocations plans. This paragraph applies to the following types of documents and their supporting records: indirect cost rate computations or proposals, cost allocation plans, and any similar accounting computations of the rate at which a particular group of costs is chargeable (such as computer usage chargeback rates or composite fringe benefit rates).

(1) *If submitted for negotiation.* If the proposal, plan, or other computation is required to be submitted to the Federal Government (or to the pass-through entity) to form the basis for negotiation of the rate, then the 3-year retention period for its supporting records starts from the date of such submission.

(2) *If not submitted for negotiation.* If the proposal, plan, or other computation is not required to be submitted to the Federal Government (or to the pass-through entity) for negotiation purposes, then the 3-year retention period for the proposal, plan, or computation and its supporting records starts from the end of the fiscal year (or other accounting period) covered by the proposal, plan, or other computation.

[↑ Back to Top](#)

§200.334 Requests for transfer of records.

The Federal awarding agency must request transfer of certain records to its custody from the non-Federal entity when it determines that the records possess long-term retention value. However, in order to avoid duplicate recordkeeping, the Federal awarding agency may make arrangements for the non-Federal entity to retain any records that are continuously needed for joint use.

[↑ Back to Top](#)

§200.335 Methods for collection, transmission and storage of information.

In accordance with the May 2013 Executive Order on Making Open and Machine Readable the New Default for Government Information, the Federal awarding agency and the non-Federal entity should, whenever practicable, collect, transmit, and store Federal award-related information in open and machine readable formats rather than in closed formats or on paper. The Federal awarding agency or pass-through entity must always provide or accept paper versions of Federal award-related information to and from the non-Federal entity upon request. If paper copies are submitted, the Federal awarding agency or pass-through entity must not require more than an original and two copies. When original records are electronic and cannot be altered, there is no need to create and retain paper copies. When original records are paper, electronic versions may be substituted through the use of duplication or other forms of electronic media provided that they are subject to periodic quality control reviews, provide reasonable safeguards against alteration, and remain readable.

[↑ Back to Top](#)

§200.336 Access to records.

(a) Records of non-Federal entities. The Federal awarding agency, Inspectors General, the Comptroller General of the United States, and the pass-through entity, or any of their authorized representatives, must have the right of access to any documents, papers, or other records of the non-Federal entity which are pertinent to the Federal award, in order to make audits, examinations, excerpts, and transcripts. The right also includes timely and reasonable access to the non-Federal entity's personnel for the purpose of interview and discussion related to such documents.

(b) Only under extraordinary and rare circumstances would such access include review of the true name of victims of a crime. Routine monitoring cannot be considered extraordinary and rare circumstances that would necessitate access to this information. When access to the true name of victims of a crime is necessary, appropriate steps to protect this sensitive information must be taken by both the non-Federal entity and the Federal awarding agency. Any such access, other than under a court order or subpoena pursuant to a bona fide confidential investigation, must be approved by the head of the Federal awarding agency or delegate.

(c) Expiration of right of access. The rights of access in this section are not limited to the required retention period but last as long as the records are retained. Federal awarding agencies and pass-through entities must not impose any other access requirements upon non-Federal entities.

[↑ Back to Top](#)

§200.337 Restrictions on public access to records.

No Federal awarding agency may place restrictions on the non-Federal entity that limit public access to the records of the non-Federal entity pertinent to a Federal award, except for protected personally identifiable information (PII) or when the Federal awarding agency can demonstrate that such records will be kept confidential and would have been exempted from disclosure pursuant to the Freedom of Information Act (5 U.S.C. 552) or controlled unclassified information pursuant to Executive Order 13556 if the records had belonged to the Federal awarding agency. The Freedom of Information Act (5 U.S.C. 552) (FOIA) does not apply to those records that remain under a non-Federal entity's control except as required under §200.315 Intangible property. Unless required by Federal, state, local, and tribal statute, non-Federal entities are not required to permit public access to their records. The non-Federal entity's records provided to a Federal agency generally will be subject to FOIA and applicable exemptions.

[78 FR 78608, Dec. 26, 2013, as amended at 79 FR 75885, Dec. 19, 2014]

[↑ Back to Top](#)

REMEDIES FOR NONCOMPLIANCE

[↑ Back to Top](#)

§200.338 Remedies for noncompliance.

If a non-Federal entity fails to comply with Federal statutes, regulations or the terms and conditions of a Federal award, the Federal awarding agency or pass-through entity may impose additional conditions, as described in §200.207 Specific conditions. If the Federal awarding agency or pass-through entity determines that noncompliance cannot be remedied by imposing additional conditions, the Federal awarding agency or pass-through entity may take one or more of the following actions, as appropriate in the circumstances:

- (a) Temporarily withhold cash payments pending correction of the deficiency by the non-Federal entity or more severe enforcement action by the Federal awarding agency or pass-through entity.
- (b) Disallow (that is, deny both use of funds and any applicable matching credit for) all or part of the cost of the activity or action not in compliance.
- (c) Wholly or partly suspend or terminate the Federal award.
- (d) Initiate suspension or debarment proceedings as authorized under 2 CFR part 180 and Federal awarding agency regulations (or in the case of a pass-through entity, recommend such a proceeding be initiated by a Federal awarding agency).
- (e) Withhold further Federal awards for the project or program.
- (f) Take other remedies that may be legally available.

[↑ Back to Top](#)

§200.339 Termination.

- (a) The Federal award may be terminated in whole or in part as follows:

- (1) By the Federal awarding agency or pass-through entity, if a non-Federal entity fails to comply with the terms and conditions of a Federal award;
- (2) By the Federal awarding agency or pass-through entity for cause;
- (3) By the Federal awarding agency or pass-through entity with the consent of the non-Federal entity, in which case the two parties must agree upon the termination conditions, including the effective date and, in the case of partial termination, the portion to be terminated; or
- (4) By the non-Federal entity upon sending to the Federal awarding agency or pass-through entity written notification setting forth the reasons for such termination, the effective date, and, in the case of partial termination, the portion to be terminated. However, if the Federal awarding agency or pass-through entity determines in the case of partial termination that the reduced or modified portion of the Federal award or subaward will not accomplish the purposes for which the Federal award was made, the Federal awarding agency or pass-through entity may terminate the Federal award in its entirety.

- (b) When a Federal award is terminated or partially terminated, both the Federal awarding agency or pass-through entity and the non-Federal entity remain responsible for compliance with the requirements in §§200.343 Closeout and 200.344 Post-closeout adjustments and continuing responsibilities.

[↑ Back to Top](#)

§200.340 Notification of termination requirement.

- (a) The Federal agency or pass-through entity must provide to the non-Federal entity a notice of termination.
- (b) If the Federal award is terminated for the non-Federal entity's failure to comply with the Federal statutes, regulations, or terms and conditions of the Federal award, the notification must state that the termination decision may be considered in evaluating future applications received from the non-Federal entity.
- (c) Upon termination of a Federal award, the Federal awarding agency must provide the information required under FFATA to the Federal Web site established to fulfill the requirements of FFATA, and update or notify any other relevant governmentwide systems or entities of any indications of poor performance as required by 41 U.S.C. 417b and 31 U.S.C. 3321 and implementing guidance at 2 CFR part 77 (forthcoming at time of publication). See also the requirements for Suspension and Debarment at 2 CFR part 180.

[78 FR 78608, Dec. 26, 2013, as amended at 79 FR 75885, Dec. 19, 2014]

[↑ Back to Top](#)

§200.341 Opportunities to object, hearings and appeals.

Upon taking any remedy for non-compliance, the Federal awarding agency must provide the non-Federal entity an opportunity to object and provide information and documentation challenging the suspension or termination action, in accordance with written processes and procedures published by the Federal awarding agency. The Federal awarding agency or pass-through entity must comply with any requirements for hearings, appeals or other administrative proceedings to which the non-Federal entity is entitled under any statute or regulation applicable to the action involved.

[78 FR 78608, Dec. 26, 2013, as amended at 79 FR 75885, Dec. 19, 2014]

[↑ Back to Top](#)

§200.342 Effects of suspension and termination.

Costs to the non-Federal entity resulting from obligations incurred by the non-Federal entity during a suspension or after termination of a Federal award or subaward are not allowable unless the Federal awarding agency or pass-through entity expressly authorizes them in the notice of suspension or termination or subsequently. However, costs during suspension or after termination are allowable if:

(a) The costs result from obligations which were properly incurred by the non-Federal entity before the effective date of suspension or termination, are not in anticipation of it; and

(b) The costs would be allowable if the Federal award was not suspended or expired normally at the end of the period of performance in which the termination takes effect.

[↑ Back to Top](#)

CLOSEOUT

[↑ Back to Top](#)

§200.343 Closeout.

The Federal awarding agency or pass-through entity will close-out the Federal award when it determines that all applicable administrative actions and all required work of the Federal award have been completed by the non-Federal entity. This section specifies the actions the non-Federal entity and Federal awarding agency or pass-through entity must take to complete this process at the end of the period of performance.

(a) The non-Federal entity must submit, no later than 90 calendar days after the end date of the period of performance, all financial, performance, and other reports as required by the terms and conditions of the Federal award. The Federal awarding agency or pass-through entity may approve extensions when requested by the non-Federal entity.

(b) Unless the Federal awarding agency or pass-through entity authorizes an extension, a non-Federal entity must liquidate all obligations incurred under the Federal award not later than 90 calendar days after the end date of the period of performance as specified in the terms and conditions of the Federal award.

(c) The Federal awarding agency or pass-through entity must make prompt payments to the non-Federal entity for allowable reimbursable costs under the Federal award being closed out.

(d) The non-Federal entity must promptly refund any balances of unobligated cash that the Federal awarding agency or pass-through entity paid in advance or paid and that are not authorized to be retained by the non-Federal entity for use in other projects. See OMB Circular A-129 and see §200.345 Collection of amounts due, for requirements regarding unreturned amounts that become delinquent debts.

(e) Consistent with the terms and conditions of the Federal award, the Federal awarding agency or pass-through entity must make a settlement for any upward or downward adjustments to the Federal share of costs after closeout reports are received.

(f) The non-Federal entity must account for any real and personal property acquired with Federal funds or received from the Federal Government in accordance with §§200.310 Insurance coverage through 200.316 Property trust relationship and 200.329 Reporting on real property.

(g) The Federal awarding agency or pass-through entity should complete all closeout actions for Federal awards no later than one year after receipt and acceptance of all required final reports.

[78 FR 78608, Dec. 26, 2013, as amended at 79 FR 75885, Dec. 19, 2014]

[↑ Back to Top](#)

POST-CLOSEOUT ADJUSTMENTS AND CONTINUING RESPONSIBILITIES

[↑ Back to Top](#)

§200.344 Post-closeout adjustments and continuing responsibilities.

(a) The closeout of a Federal award does not affect any of the following:

(1) The right of the Federal awarding agency or pass-through entity to disallow costs and recover funds on the basis of a later audit or other review. The Federal awarding agency or pass-through entity must make any cost disallowance determination and notify the non-Federal entity within the record retention period.

(2) The obligation of the non-Federal entity to return any funds due as a result of later refunds, corrections, or other transactions including final indirect cost rate adjustments.

(3) Audit requirements in Subpart F—Audit Requirements of this part.

(4) Property management and disposition requirements in Subpart D—Post Federal Award Requirements of this part, §§200.310 Insurance Coverage through 200.316 Property trust relationship.

(5) Records retention as required in Subpart D—Post Federal Award Requirements of this part, §§200.333 Retention requirements for records through 200.337 Restrictions on public access to records.

(b) After closeout of the Federal award, a relationship created under the Federal award may be modified or ended in whole or in part with the consent of the Federal awarding agency or pass-through entity and the non-Federal entity, provided the responsibilities of the non-Federal entity referred to in paragraph (a) of this section, including those for property management as applicable, are considered and provisions made for continuing responsibilities of the non-Federal entity, as appropriate.

[78 FR 78608, Dec. 26, 2013, as amended at 79 FR 75885, Dec. 19, 2014]

[↑ Back to Top](#)

COLLECTION OF AMOUNTS DUE

[↑ Back to Top](#)

§200.345 Collection of amounts due.

(a) Any funds paid to the non-Federal entity in excess of the amount to which the non-Federal entity is finally determined to be entitled under the terms of the Federal award constitute a debt to the Federal Government. If not paid within 90 calendar days after demand, the Federal awarding agency may reduce the debt by:

- (1) Making an administrative offset against other requests for reimbursements;
- (2) Withholding advance payments otherwise due to the non-Federal entity; or
- (3) Other action permitted by Federal statute.

(b) Except where otherwise provided by statutes or regulations, the Federal awarding agency will charge interest on an overdue debt in accordance with the Federal Claims Collection Standards (31 CFR parts 900 through 999). The date from which interest is computed is not extended by litigation or the filing of any form of appeal.

[↑ Back to Top](#)

Subpart E—Cost Principles

[↑ Back to Top](#)

GENERAL PROVISIONS

[↑ Back to Top](#)

§200.400 Policy guide.

The application of these cost principles is based on the fundamental premises that:

(a) The non-Federal entity is responsible for the efficient and effective administration of the Federal award through the application of sound management practices.

(b) The non-Federal entity assumes responsibility for administering Federal funds in a manner consistent with underlying agreements, program objectives, and the terms and conditions of the Federal award.

(c) The non-Federal entity, in recognition of its own unique combination of staff, facilities, and experience, has the primary responsibility for employing whatever form of sound organization and management techniques may be necessary in order to assure proper and efficient administration of the Federal award.

(d) The application of these cost principles should require no significant changes in the internal accounting policies and practices of the non-Federal entity. However, the accounting practices of the non-Federal entity must be consistent with these cost principles and support the accumulation of costs as required by the principles, and must provide for adequate documentation to support costs charged to the Federal award.

(e) In reviewing, negotiating and approving cost allocation plans or indirect cost proposals, the cognizant agency for indirect costs should generally assure that the non-Federal entity is applying these cost accounting principles on a consistent basis during their review and negotiation of indirect cost proposals. Where wide variations exist in the treatment of a given cost item by the non-Federal entity, the reasonableness and equity of such treatments should be fully considered. See §200.56 Indirect (facilities & administrative (F&A)) costs.

(f) For non-Federal entities that educate and engage students in research, the dual role of students as both trainees and employees (including pre- and post-doctoral staff) contributing to the completion of Federal awards for research must be recognized in the application of these principles.

(g) The non-Federal entity may not earn or keep any profit resulting from Federal financial assistance, unless explicitly authorized by the terms and conditions of the Federal award. See also §200.307 Program income.

[78 FR 78608, Dec. 26, 2013, as amended at 79 FR 75885, Dec. 19, 2014]

[↑ Back to Top](#)

§200.401 Application.

(a) *General.* These principles must be used in determining the allowable costs of work performed by the non-Federal entity under Federal awards. These principles also must be used by the non-Federal entity as a guide in the pricing of fixed-price contracts and subcontracts where costs are used in determining the appropriate price. The principles do not apply to:

(1) Arrangements under which Federal financing is in the form of loans, scholarships, fellowships, traineeships, or other fixed amounts based on such items as education allowance or published tuition rates and fees.

(2) For IHEs, capitation awards, which are awards based on case counts or number of beneficiaries according to the terms and conditions of the Federal award.

(3) Fixed amount awards. See also Subpart A—Acronyms and Definitions, §§200.45 Fixed amount awards and 200.201 Use of grant agreements (including fixed amount awards), cooperative agreements, and contracts.

(4) Federal awards to hospitals (see Appendix IX to Part 200—Hospital Cost Principles).

(5) Other awards under which the non-Federal entity is not required to account to the Federal Government for actual costs incurred.

(b) *Federal Contract.* Where a Federal contract awarded to a non-Federal entity is subject to the Cost Accounting Standards (CAS), it incorporates the applicable CAS clauses, Standards, and CAS administration requirements per the 48 CFR Chapter 99 and 48 CFR part 30 (FAR Part 30). CAS applies directly to the CAS-covered contract and the Cost Accounting Standards at 48 CFR parts 9904 or 9905 takes precedence over the cost principles in this Subpart E—Cost Principles of this part with respect to the allocation of costs. When a contract with a non-Federal entity is subject to full CAS coverage, the allowability of certain costs under the cost principles will be affected by the allocation provisions of the Cost Accounting Standards (e.g., CAS 414—48 CFR 9904.414, Cost of Money as an Element of the Cost of Facilities Capital, and CAS 417—48 CFR 9904.417, Cost of Money as an Element of the Cost of Capital Assets Under Construction), apply rather the allowability provisions of §200.449 Interest. In complying with those requirements, the non-Federal entity's application of cost accounting practices for estimating, accumulating, and reporting costs for other Federal awards and other cost objectives under the CAS-covered contract still must be consistent with its cost accounting practices for the CAS-covered contracts. In all cases, only one set of accounting records needs to be maintained for the allocation of costs by the non-Federal entity.

(c) *Exemptions.* Some nonprofit organizations, because of their size and nature of operations, can be considered to be similar to for-profit entities for purpose of applicability of cost principles. Such nonprofit organizations must operate under Federal cost principles applicable to for-profit entities located at 48 CFR 31.2. A listing of these organizations is contained in Appendix VIII to Part 200—Nonprofit Organizations Exempted From Subpart E—Cost Principles of this part. Other organizations, as approved by the cognizant agency for indirect costs, may be added from time to time.

[↑ Back to Top](#)

BASIC CONSIDERATIONS

[↑ Back to Top](#)

§200.402 Composition of costs.

Total cost. The total cost of a Federal award is the sum of the allowable direct and allocable indirect costs less any applicable credits.

[↑ Back to Top](#)

§200.403 Factors affecting allowability of costs.

Except where otherwise authorized by statute, costs must meet the following general criteria in order to be allowable under Federal awards:

(a) Be necessary and reasonable for the performance of the Federal award and be allocable thereto under these principles.

(b) Conform to any limitations or exclusions set forth in these principles or in the Federal award as to types or amount of cost items.

(c) Be consistent with policies and procedures that apply uniformly to both federally-financed and other activities of the non-Federal entity.

(d) Be accorded consistent treatment. A cost may not be assigned to a Federal award as a direct cost if any other cost incurred for the same purpose in like circumstances has been allocated to the Federal award as an indirect cost.

(e) Be determined in accordance with generally accepted accounting principles (GAAP), except, for state and local governments and Indian tribes only, as otherwise provided for in this part.

(f) Not be included as a cost or used to meet cost sharing or matching requirements of any other federally-financed program in either the current or a prior period. See also §200.306 Cost sharing or matching paragraph (b).

(g) Be adequately documented. See also §§200.300 Statutory and national policy requirements through 200.309 Period of performance of this part.

[↑ Back to Top](#)

§200.404 Reasonable costs.

A cost is reasonable if, in its nature and amount, it does not exceed that which would be incurred by a prudent person under the circumstances prevailing at the time the decision was made to incur the cost. The question of reasonableness is particularly important when the non-Federal entity is predominantly federally-funded. In determining reasonableness of a given cost, consideration must be given to:

(a) Whether the cost is of a type generally recognized as ordinary and necessary for the operation of the non-Federal entity or the proper and efficient performance of the Federal award.

(b) The restraints or requirements imposed by such factors as: sound business practices; arm's-length bargaining; Federal, state, local, tribal, and other laws and regulations; and terms and conditions of the Federal award.

(c) Market prices for comparable goods or services for the geographic area.

(d) Whether the individuals concerned acted with prudence in the circumstances considering their responsibilities to the non-Federal entity, its employees, where applicable its students or membership, the public at large, and the Federal Government.

(e) Whether the non-Federal entity significantly deviates from its established practices and policies regarding the incurrence of costs, which may unjustifiably increase the Federal award's cost.

[78 FR 78608, Dec. 26, 2013, as amended at 79 FR 75885, Dec. 19, 2014]

[↑ Back to Top](#)

§200.405 Allocable costs.

(a) A cost is allocable to a particular Federal award or other cost objective if the goods or services involved are chargeable or assignable to that Federal award or cost objective in accordance with relative benefits received. This standard is met if the cost:

(1) Is incurred specifically for the Federal award;

(2) Benefits both the Federal award and other work of the non-Federal entity and can be distributed in proportions that may be approximated using reasonable methods; and

(3) Is necessary to the overall operation of the non-Federal entity and is assignable in part to the Federal award in accordance with the principles in this subpart.

(b) All activities which benefit from the non-Federal entity's indirect (F&A) cost, including unallowable activities and donated services by the non-Federal entity or third parties, will receive an appropriate allocation of indirect costs.

(c) Any cost allocable to a particular Federal award under the principles provided for in this part may not be charged to other Federal awards to overcome fund deficiencies, to avoid restrictions imposed by Federal statutes, regulations, or terms and conditions of the Federal awards, or for other reasons. However, this prohibition would not preclude the non-Federal entity from shifting costs that are allowable under two or more Federal awards in accordance with existing Federal statutes, regulations, or the terms and conditions of the Federal awards.

(d) Direct cost allocation principles. If a cost benefits two or more projects or activities in proportions that can be determined without undue effort or cost, the cost must be allocated to the projects based on the proportional benefit. If a cost benefits two or more projects or activities in proportions that cannot be determined because of the interrelationship of the work involved, then, notwithstanding paragraph (c) of this section, the costs may be allocated or transferred to benefitted projects on any reasonable documented basis. Where the purchase of equipment or other capital asset is specifically authorized under a Federal award, the costs are assignable to the Federal award regardless of the use that may be made of the equipment or other capital asset involved when no longer needed for the purpose for which it was originally required. See also §§200.310 Insurance coverage through 200.316 Property trust relationship and 200.439 Equipment and other capital expenditures.

(e) If the contract is subject to CAS, costs must be allocated to the contract pursuant to the Cost Accounting Standards. To the extent that CAS is applicable, the allocation of costs in accordance with CAS takes precedence over the allocation provisions in this part.

[78 FR 78608, Dec. 26, 2013, as amended at 79 FR 75885, Dec. 19, 2014]

[↑ Back to Top](#)

§200.406 Applicable credits.

(a) Applicable credits refer to those receipts or reduction-of-expenditure-type transactions that offset or reduce expense items allocable to the Federal award as direct or indirect (F&A) costs. Examples of such transactions are: purchase discounts, rebates or allowances, recoveries or indemnities on losses, insurance refunds or rebates, and adjustments of overpayments or erroneous charges. To the extent that such credits accruing to or received by the non-Federal entity relate to allowable costs, they must be credited to the Federal award either as a cost reduction or cash refund, as appropriate.

(b) In some instances, the amounts received from the Federal Government to finance activities or service operations of the non-Federal entity should be treated as applicable credits. Specifically, the concept of netting such credit items (including any amounts used to meet cost sharing or matching requirements) must be recognized in determining the rates or amounts to be charged to the Federal award. (See §§200.436 Depreciation and 200.468 Specialized service facilities, for areas of potential application in the matter of Federal financing of activities.)

[78 FR 78608, Dec. 26, 2013, as amended at 79 FR 75885, Dec. 19, 2014]

[↑ Back to Top](#)

§200.407 Prior written approval (prior approval).

Under any given Federal award, the reasonableness and allocability of certain items of costs may be difficult to determine. In order to avoid subsequent disallowance or dispute based on unreasonableness or nonallocability, the non-Federal entity may seek the prior written approval of the cognizant agency for indirect costs or the Federal awarding agency in advance of the incurrence of special or unusual costs. Prior written approval should include the timeframe or scope of the agreement. The absence of prior written approval on any element of cost will not, in itself, affect the reasonableness or allocability of that element, unless prior approval is specifically required for allowability as described under certain circumstances in the following sections of this part:

(a) §200.201 Use of grant agreements (including fixed amount awards), cooperative agreements, and contracts, paragraph (b)(5);

(b) §200.306 Cost sharing or matching;

(c) §200.307 Program income;

(d) §200.308 Revision of budget and program plans;

(e) §200.311 Real property;

- (f) §200.313 Equipment;
- (g) §200.332 Fixed amount subawards;
- (h) §200.413 Direct costs, paragraph (c);
- (i) §200.430 Compensation—personal services, paragraph (h);
- (j) §200.431 Compensation—fringe benefits;
- (k) §200.438 Entertainment costs;
- (l) §200.439 Equipment and other capital expenditures;
- (m) §200.440 Exchange rates;
- (n) §200.441 Fines, penalties, damages and other settlements;
- (o) §200.442 Fund raising and investment management costs;
- (p) §200.445 Goods or services for personal use;
- (q) §200.447 Insurance and indemnification;
- (r) §200.454 Memberships, subscriptions, and professional activity costs, paragraph (c);
- (s) §200.455 Organization costs;
- (t) §200.456 Participant support costs;
- (u) §200.458 Pre-award costs;
- (v) §200.462 Rearrangement and reconversion costs;
- (w) §200.467 Selling and marketing costs;
- (x) §200.470 Taxes (including Value Added Tax); and
- (y) §200.474 Travel costs.

[78 FR 78608, Dec. 26, 2013, as amended at 79 FR 75885, Dec. 19, 2014]

[↑ Back to Top](#)

§200.408 Limitation on allowance of costs.

The Federal award may be subject to statutory requirements that limit the allowability of costs. When the maximum amount allowable under a limitation is less than the total amount determined in accordance with the principles in this part, the amount not recoverable under the Federal award may not be charged to the Federal award.

[↑ Back to Top](#)

§200.409 Special considerations.

In addition to the basic considerations regarding the allowability of costs highlighted in this subtitle, other subtitles in this part describe special considerations and requirements applicable to states, local governments, Indian tribes, and IHEs. In addition, certain provisions among the items of cost in this subpart, are only applicable to certain types of non-Federal entities, as specified in the following sections:

- (a) Direct and Indirect (F&A) Costs (§§200.412 Classification of costs through 200.415 Required certifications) of this subpart;
- (b) Special Considerations for States, Local Governments and Indian Tribes (§§200.416 Cost allocation plans and indirect cost proposals and 200.417 Interagency service) of this subpart; and
- (c) Special Considerations for Institutions of Higher Education (§§200.418 Costs incurred by states and local governments and 200.419 Cost accounting standards and disclosure statement) of this subpart.

[↑ Back to Top](#)

§200.410 Collection of unallowable costs.

Payments made for costs determined to be unallowable by either the Federal awarding agency, cognizant agency for indirect costs, or pass-through entity, either as direct or indirect costs, must be refunded (including interest) to the Federal Government in accordance with instructions from the Federal agency that determined the costs are unallowable unless Federal statute or regulation directs otherwise. See also Subpart D—Post Federal Award Requirements of this part, §§200.300 Statutory and national policy requirements through 200.309 Period of performance.

[↑ Back to Top](#)

§200.411 Adjustment of previously negotiated indirect (F&A) cost rates containing unallowable costs.

- (a) Negotiated indirect (F&A) cost rates based on a proposal later found to have included costs that:
 - (1) Are unallowable as specified by Federal statutes, regulations or the terms and conditions of a Federal award; or
 - (2) Are unallowable because they are not allocable to the Federal award(s), must be adjusted, or a refund must be made, in accordance with the requirements of this section. These adjustments or refunds are designed to correct the proposals used to establish the rates and do not

constitute a reopening of the rate negotiation. The adjustments or refunds will be made regardless of the type of rate negotiated (predetermined, final, fixed, or provisional).

(b) For rates covering a future fiscal year of the non-Federal entity, the unallowable costs will be removed from the indirect (F&A) cost pools and the rates appropriately adjusted.

(c) For rates covering a past period, the Federal share of the unallowable costs will be computed for each year involved and a cash refund (including interest chargeable in accordance with applicable regulations) will be made to the Federal Government. If cash refunds are made for past periods covered by provisional or fixed rates, appropriate adjustments will be made when the rates are finalized to avoid duplicate recovery of the unallowable costs by the Federal Government.

(d) For rates covering the current period, either a rate adjustment or a refund, as described in paragraphs (b) and (c) of this section, must be required by the cognizant agency for indirect costs. The choice of method must be at the discretion of the cognizant agency for indirect costs, based on its judgment as to which method would be most practical.

(e) The amount or proportion of unallowable costs included in each year's rate will be assumed to be the same as the amount or proportion of unallowable costs included in the base year proposal used to establish the rate.

[↑ Back to Top](#)

DIRECT AND INDIRECT (F&A) COSTS

[↑ Back to Top](#)

§200.412 Classification of costs.

There is no universal rule for classifying certain costs as either direct or indirect (F&A) under every accounting system. A cost may be direct with respect to some specific service or function, but indirect with respect to the Federal award or other final cost objective. Therefore, it is essential that each item of cost incurred for the same purpose be treated consistently in like circumstances either as a direct or an indirect (F&A) cost in order to avoid possible double-charging of Federal awards. Guidelines for determining direct and indirect (F&A) costs charged to Federal awards are provided in this subpart.

[↑ Back to Top](#)

§200.413 Direct costs.

(a) *General.* Direct costs are those costs that can be identified specifically with a particular final cost objective, such as a Federal award, or other internally or externally funded activity, or that can be directly assigned to such activities relatively easily with a high degree of accuracy. Costs incurred for the same purpose in like circumstances must be treated consistently as either direct or indirect (F&A) costs. See also §200.405 Allocable costs.

(b) *Application to Federal awards.* Identification with the Federal award rather than the nature of the goods and services involved is the determining factor in distinguishing direct from indirect (F&A) costs of Federal awards. Typical costs charged directly to a Federal award are the compensation of employees who work on that award, their related fringe benefit costs, the costs of materials and other items of expense incurred for the Federal award. If directly related to a specific award, certain costs that otherwise would be treated as indirect costs may also include extraordinary utility consumption, the cost of materials supplied from stock or services rendered by specialized facilities or other institutional service operations.

(c) The salaries of administrative and clerical staff should normally be treated as indirect (F&A) costs. Direct charging of these costs may be appropriate only if all of the following conditions are met:

- (1) Administrative or clerical services are integral to a project or activity;
- (2) Individuals involved can be specifically identified with the project or activity;
- (3) Such costs are explicitly included in the budget or have the prior written approval of the Federal awarding agency; and
- (4) The costs are not also recovered as indirect costs.

(d) *Minor items.* Any direct cost of minor amount may be treated as an indirect (F&A) cost for reasons of practicality where such accounting treatment for that item of cost is consistently applied to all Federal and non-Federal cost objectives.

(e) The costs of certain activities are not allowable as charges to Federal awards. However, even though these costs are unallowable for purposes of computing charges to Federal awards, they nonetheless must be treated as direct costs for purposes of determining indirect (F&A) cost rates and be allocated their equitable share of the non-Federal entity's indirect costs if they represent activities which:

- (1) Include the salaries of personnel,
- (2) Occupy space, and
- (3) Benefit from the non-Federal entity's indirect (F&A) costs.

(f) For nonprofit organizations, the costs of activities performed by the non-Federal entity primarily as a service to members, clients, or the general public when significant and necessary to the non-Federal entity's mission must be treated as direct costs whether or not allowable, and be allocated an equitable share of indirect (F&A) costs. Some examples of these types of activities include:

- (1) Maintenance of membership rolls, subscriptions, publications, and related functions. See also §200.454 Memberships, subscriptions, and professional activity costs.
- (2) Providing services and information to members, legislative or administrative bodies, or the public. See also §§200.454 Memberships, subscriptions, and professional activity costs and 200.450 Lobbying.
- (3) Promotion, lobbying, and other forms of public relations. See also §§200.421 Advertising and public relations and 200.450 Lobbying.

(4) Conferences except those held to conduct the general administration of the non-Federal entity. See also §200.432 Conferences.

(5) Maintenance, protection, and investment of special funds not used in operation of the non-Federal entity. See also §200.442 Fund raising and investment management costs.

(6) Administration of group benefits on behalf of members or clients, including life and hospital insurance, annuity or retirement plans, and financial aid. See also §200.431 Compensation—fringe benefits.

[78 FR 78608, Dec. 26, 2013, as amended at 79 FR 75885, Dec. 19, 2014]

[↑ Back to Top](#)

§200.414 Indirect (F&A) costs.

(a) *Facilities and Administration Classification.* For major IHEs and major nonprofit organizations, indirect (F&A) costs must be classified within two broad categories: “Facilities” and “Administration.” “Facilities” is defined as depreciation on buildings, equipment and capital improvement, interest on debt associated with certain buildings, equipment and capital improvements, and operations and maintenance expenses. “Administration” is defined as general administration and general expenses such as the director’s office, accounting, personnel and all other types of expenditures not listed specifically under one of the subcategories of “Facilities” (including cross allocations from other pools, where applicable). For nonprofit organizations, library expenses are included in the “Administration” category; for institutions of higher education, they are included in the “Facilities” category. Major IHEs are defined as those required to use the Standard Format for Submission as noted in Appendix III to Part 200—Indirect (F&A) Costs Identification and Assignment, and Rate Determination for Institutions of Higher Education (IHEs) paragraph C. 11. Major nonprofit organizations are those which receive more than \$10 million dollars in direct Federal funding.

(b) *Diversity of nonprofit organizations.* Because of the diverse characteristics and accounting practices of nonprofit organizations, it is not possible to specify the types of cost which may be classified as indirect (F&A) cost in all situations. Identification with a Federal award rather than the nature of the goods and services involved is the determining factor in distinguishing direct from indirect (F&A) costs of Federal awards. However, typical examples of indirect (F&A) cost for many nonprofit organizations may include depreciation on buildings and equipment, the costs of operating and maintaining facilities, and general administration and general expenses, such as the salaries and expenses of executive officers, personnel administration, and accounting.

(c) *Federal Agency Acceptance of Negotiated Indirect Cost Rates.* (See also §200.306 Cost sharing or matching.)

(1) The negotiated rates must be accepted by all Federal awarding agencies. A Federal awarding agency may use a rate different from the negotiated rate for a class of Federal awards or a single Federal award only when required by Federal statute or regulation, or when approved by a Federal awarding agency head or delegate based on documented justification as described in paragraph (c)(3) of this section.

(2) The Federal awarding agency head or delegate must notify OMB of any approved deviations.

(3) The Federal awarding agency must implement, and make publicly available, the policies, procedures and general decision making criteria that their programs will follow to seek and justify deviations from negotiated rates.

(4) As required under §200.203 Notices of funding opportunities, the Federal awarding agency must include in the notice of funding opportunity the policies relating to indirect cost rate reimbursement, matching, or cost share as approved under paragraph (e)(1) of this section. As appropriate, the Federal agency should incorporate discussion of these policies into Federal awarding agency outreach activities with non-Federal entities prior to the posting of a notice of funding opportunity.

(d) Pass-through entities are subject to the requirements in §200.331 Requirements for pass-through entities, paragraph (a)(4).

(e) Requirements for development and submission of indirect (F&A) cost rate proposals and cost allocation plans are contained in Appendices III-VII and Appendix IX as follows:

(1) Appendix III to Part 200—Indirect (F&A) Costs Identification and Assignment, and Rate Determination for Institutions of Higher Education (IHEs);

(2) Appendix IV to Part 200—Indirect (F&A) Costs Identification and Assignment, and Rate Determination for Nonprofit Organizations;

(3) Appendix V to Part 200—State/Local Governmentwide Central Service Cost Allocation Plans;

(4) Appendix VI to Part 200—Public Assistance Cost Allocation Plans;

(5) Appendix VII to Part 200—States and Local Government and Indian Tribe Indirect Cost Proposals; and

(6) Appendix IX to Part 200—Hospital Cost Principles.

(f) In addition to the procedures outlined in the appendices in paragraph (e) of this section, any non-Federal entity that has never received a negotiated indirect cost rate, except for those non-Federal entities described in Appendix VII to Part 200—States and Local Government and Indian Tribe Indirect Cost Proposals, paragraph D.1.b, may elect to charge a de minimis rate of 10% of modified total direct costs (MTDC) which may be used indefinitely. As described in §200.403 Factors affecting allowability of costs, costs must be consistently charged as either indirect or direct costs, but may not be double charged or inconsistently charged as both. If chosen, this methodology once elected must be used consistently for all Federal awards until such time as a non-Federal entity chooses to negotiate for a rate, which the non-Federal entity may apply to do at any time.

(g) Any non-Federal entity that has a current federally negotiated indirect cost rate may apply for a one-time extension of the rates in that agreement for a period of up to four years. This extension will be subject to the review and approval of the cognizant agency for indirect costs. If an extension is granted the non-Federal entity may not request a rate review until the extension period ends. At the end of the 4-year extension, the non-Federal entity must re-apply to negotiate a rate. Subsequent one-time extensions (up to four years) are permitted if a renegotiation is completed between each extension request.

[78 FR 78608, Dec. 26, 2013, as amended at 79 FR 75886, Dec. 19, 2014]

[↑ Back to Top](#)

§200.415 Required certifications.

Required certifications include:

(a) To assure that expenditures are proper and in accordance with the terms and conditions of the Federal award and approved project budgets, the annual and final fiscal reports or vouchers requesting payment under the agreements must include a certification, signed by an official who is authorized to legally bind the non-Federal entity, which reads as follows: "By signing this report, I certify to the best of my knowledge and belief that the report is true, complete, and accurate, and the expenditures, disbursements and cash receipts are for the purposes and objectives set forth in the terms and conditions of the Federal award. I am aware that any false, fictitious, or fraudulent information, or the omission of any material fact, may subject me to criminal, civil or administrative penalties for fraud, false statements, false claims or otherwise. (U.S. Code Title 18, Section 1001 and Title 31, Sections 3729-3730 and 3801-3812)."

(b) Certification of cost allocation plan or indirect (F&A) cost rate proposal. Each cost allocation plan or indirect (F&A) cost rate proposal must comply with the following:

(1) A proposal to establish a cost allocation plan or an indirect (F&A) cost rate, whether submitted to a Federal cognizant agency for indirect costs or maintained on file by the non-Federal entity, must be certified by the non-Federal entity using the Certificate of Cost Allocation Plan or Certificate of Indirect Costs as set forth in Appendices III through VII, and Appendix IX. The certificate must be signed on behalf of the non-Federal entity by an individual at a level no lower than vice president or chief financial officer of the non-Federal entity that submits the proposal.

(2) Unless the non-Federal entity has elected the option under §200.414 Indirect (F&A) costs, paragraph (f), the Federal Government may either disallow all indirect (F&A) costs or unilaterally establish such a plan or rate when the non-Federal entity fails to submit a certified proposal for establishing such a plan or rate in accordance with the requirements. Such a plan or rate may be based upon audited historical data or such other data that have been furnished to the cognizant agency for indirect costs and for which it can be demonstrated that all unallowable costs have been excluded. When a cost allocation plan or indirect cost rate is unilaterally established by the Federal Government because the non-Federal entity failed to submit a certified proposal, the plan or rate established will be set to ensure that potentially unallowable costs will not be reimbursed.

(c) Certifications by non-profit organizations as appropriate that they did not meet the definition of a major nonprofit organization as defined in §200.414 Indirect (F&A) costs, paragraph (a).

(d) See also §200.450 Lobbying for another required certification.

[78 FR 78608, Dec. 26, 2013, as amended at 79 FR 75886, Dec. 19, 2014]

[↑ Back to Top](#)

SPECIAL CONSIDERATIONS FOR STATES, LOCAL GOVERNMENTS AND INDIAN TRIBES

[↑ Back to Top](#)

§200.416 Cost allocation plans and indirect cost proposals.

(a) For states, local governments and Indian tribes, certain services, such as motor pools, computer centers, purchasing, accounting, etc., are provided to operating agencies on a centralized basis. Since Federal awards are performed within the individual operating agencies, there needs to be a process whereby these central service costs can be identified and assigned to benefitted activities on a reasonable and consistent basis. The central service cost allocation plan provides that process.

(b) Individual operating agencies (governmental department or agency), normally charge Federal awards for indirect costs through an indirect cost rate. A separate indirect cost rate(s) proposal for each operating agency is usually necessary to claim indirect costs under Federal awards. Indirect costs include:

(1) The indirect costs originating in each department or agency of the governmental unit carrying out Federal awards and

(2) The costs of central governmental services distributed through the central service cost allocation plan and not otherwise treated as direct costs.

(c) The requirements for development and submission of cost allocation plans (for central service costs and public assistance programs) and indirect cost rate proposals are contained in appendices IV, V and VI to this part.

[↑ Back to Top](#)

§200.417 Interagency service.

The cost of services provided by one agency to another within the governmental unit may include allowable direct costs of the service plus a pro-rated share of indirect costs. A standard indirect cost allowance equal to ten percent of the direct salary and wage cost of providing the service (excluding overtime, shift premiums, and fringe benefits) may be used in lieu of determining the actual indirect costs of the service. These services do not include centralized services included in central service cost allocation plans as described in Appendix V to Part 200—State/Local Government and Indian Tribe-Wide Central Service Cost Allocation Plans.

[↑ Back to Top](#)

SPECIAL CONSIDERATIONS FOR INSTITUTIONS OF HIGHER EDUCATION

[↑ Back to Top](#)

§200.418 Costs incurred by states and local governments.

Costs incurred or paid by a state or local government on behalf of its IHEs for fringe benefit programs, such as pension costs and FICA and any other costs specifically incurred on behalf of, and in direct benefit to, the IHEs, are allowable costs of such IHEs whether or not these costs are recorded in the accounting records of the institutions, subject to the following:

- (a) The costs meet the requirements of §§200.402 Composition of costs through 200.411 Adjustment of previously negotiated indirect (F&A) cost rates containing unallowable costs, of this subpart;
- (b) The costs are properly supported by approved cost allocation plans in accordance with applicable Federal cost accounting principles in this part; and
- (c) The costs are not otherwise borne directly or indirectly by the Federal Government.

[↑ Back to Top](#)

§200.419 Cost accounting standards and disclosure statement.

(a) An IHE that receives aggregate Federal awards totaling \$50 million or more in Federal awards subject to this part in its most recently completed fiscal year must comply with the Cost Accounting Standards Board's cost accounting standards located at 48 CFR 9905.501, 9905.502, 9905.505, and 9905.506. CAS-covered contracts awarded to the IHEs are subject to the CAS requirements at 48 CFR 9900 through 9999 and 48 CFR part 30 (FAR Part 30).

(b) *Disclosure statement.* An IHE that receives aggregate Federal awards totaling \$50 million or more subject to this part during its most recently completed fiscal year must disclose their cost accounting practices by filing a Disclosure Statement (DS-2), which is reproduced in Appendix III to Part 200—Indirect (F&A) Costs Identification and Assignment, and Rate Determination for Institutions of Higher Education (IHEs). With the approval of the cognizant agency for indirect costs, an IHE may meet the DS-2 submission by submitting the DS-2 for each business unit that received \$50 million or more in Federal awards.

(1) The DS-2 must be submitted to the cognizant agency for indirect costs with a copy to the IHE's cognizant agency for audit.

(2) An IHE is responsible for maintaining an accurate DS-2 and complying with disclosed cost accounting practices. An IHE must file amendments to the DS-2 to the cognizant agency for indirect costs six months in advance of a disclosed practice being changed to comply with a new or modified standard, or when a practice is changed for other reasons. An IHE may proceed with implementing the change only if it has not been notified by the Federal cognizant agency for indirect costs that either a longer period will be needed for review or there are concerns with the potential change within the six months period. Amendments of a DS-2 may be submitted at any time. Resubmission of a complete, updated DS-2 is discouraged except when there are extensive changes to disclosed practices.

(3) *Cost and funding adjustments.* Cost adjustments must be made by the cognizant agency for indirect costs if an IHE fails to comply with the cost policies in this part or fails to consistently follow its established or disclosed cost accounting practices when estimating, accumulating or reporting the costs of Federal awards, and the aggregate cost impact on Federal awards is material. The cost adjustment must normally be made on an aggregate basis for all affected Federal awards through an adjustment of the IHE's future F&A costs rates or other means considered appropriate by the cognizant agency for indirect costs. Under the terms of CAS covered contracts, adjustments in the amount of funding provided may also be required when the estimated proposal costs were not determined in accordance with established cost accounting practices.

(4) *Overpayments.* Excess amounts paid in the aggregate by the Federal Government under Federal awards due to a noncompliant cost accounting practice used to estimate, accumulate, or report costs must be credited or refunded, as deemed appropriate by the cognizant agency for indirect costs. Interest applicable to the excess amounts paid in the aggregate during the period of noncompliance must also be determined and collected in accordance with applicable Federal agency regulations.

(5) *Compliant cost accounting practice changes.* Changes from one compliant cost accounting practice to another compliant practice that are approved by the cognizant agency for indirect costs may require cost adjustments if the change has a material effect on Federal awards and the changes are deemed appropriate by the cognizant agency for indirect costs.

(6) *Responsibilities.* The cognizant agency for indirect cost must:

(i) Determine cost adjustments for all Federal awards in the aggregate on behalf of the Federal Government. Actions of the cognizant agency for indirect cost in making cost adjustment determinations must be coordinated with all affected Federal awarding agencies to the extent necessary.

(ii) Prescribe guidelines and establish internal procedures to promptly determine on behalf of the Federal Government that a DS-2 adequately discloses the IHE's cost accounting practices and that the disclosed practices are compliant with applicable CAS and the requirements of this part.

(iii) Distribute to all affected Federal awarding agencies any DS-2 determination of adequacy or noncompliance.

[78 FR 78608, Dec. 26, 2013, as amended at 79 FR 75886, Dec. 19, 2014]

[↑ Back to Top](#)

GENERAL PROVISIONS FOR SELECTED ITEMS OF COST

[↑ Back to Top](#)

§200.420 Considerations for selected items of cost.

This section provides principles to be applied in establishing the allowability of certain items involved in determining cost, in addition to the requirements of Subtitle II. Basic Considerations of this subpart. These principles apply whether or not a particular item of cost is properly treated as direct cost or indirect (F&A) cost. Failure to mention a particular item of cost is not intended to imply that it is either allowable or unallowable; rather, determination as to allowability in each case should be based on the treatment provided for similar or related items of cost, and based on the principles described in §§200.402 Composition of costs through 200.411 Adjustment of previously negotiated indirect (F&A) cost rates containing unallowable costs. In case of a discrepancy between the provisions of a specific Federal award and the provisions below, the Federal award governs. Criteria outlined in §200.403 Factors affecting allowability of costs must be applied in determining allowability. See also §200.102 Exceptions.

[↑ Back to Top](#)

§200.421 Advertising and public relations.

(a) The term advertising costs means the costs of advertising media and corollary administrative costs. Advertising media include magazines, newspapers, radio and television, direct mail, exhibits, electronic or computer transmittals, and the like.

(b) The only allowable advertising costs are those which are solely for:

(1) The recruitment of personnel required by the non-Federal entity for performance of a Federal award (See also §200.463 Recruiting costs);

(2) The procurement of goods and services for the performance of a Federal award;

(3) The disposal of scrap or surplus materials acquired in the performance of a Federal award except when non-Federal entities are reimbursed for disposal costs at a predetermined amount; or

(4) Program outreach and other specific purposes necessary to meet the requirements of the Federal award.

(c) The term “public relations” includes community relations and means those activities dedicated to maintaining the image of the non-Federal entity or maintaining or promoting understanding and favorable relations with the community or public at large or any segment of the public.

(d) The only allowable public relations costs are:

(1) Costs specifically required by the Federal award;

(2) Costs of communicating with the public and press pertaining to specific activities or accomplishments which result from performance of the Federal award (these costs are considered necessary as part of the outreach effort for the Federal award); or

(3) Costs of conducting general liaison with news media and government public relations officers, to the extent that such activities are limited to communication and liaison necessary to keep the public informed on matters of public concern, such as notices of funding opportunities, financial matters, etc.

(e) Unallowable advertising and public relations costs include the following:

(1) All advertising and public relations costs other than as specified in paragraphs (b) and (d) of this section;

(2) Costs of meetings, conventions, convocations, or other events related to other activities of the entity (see also §200.432 Conferences), including:

(i) Costs of displays, demonstrations, and exhibits;

(ii) Costs of meeting rooms, hospitality suites, and other special facilities used in conjunction with shows and other special events; and

(iii) Salaries and wages of employees engaged in setting up and displaying exhibits, making demonstrations, and providing briefings;

(3) Costs of promotional items and memorabilia, including models, gifts, and souvenirs;

(4) Costs of advertising and public relations designed solely to promote the non-Federal entity.

[↑ Back to Top](#)

§200.422 Advisory councils.

Costs incurred by advisory councils or committees are unallowable unless authorized by statute, the Federal awarding agency or as an indirect cost where allocable to Federal awards. See §200.444 General costs of government, applicable to states, local governments and Indian tribes.

[↑ Back to Top](#)

§200.423 Alcoholic beverages.

Costs of alcoholic beverages are unallowable.

[↑ Back to Top](#)

§200.424 Alumni/ae activities.

Costs incurred by IHEs for, or in support of, alumni/ae activities are unallowable.

[↑ Back to Top](#)

§200.425 Audit services.

(a) A reasonably proportionate share of the costs of audits required by, and performed in accordance with, the Single Audit Act Amendments of 1996 (31 U.S.C. 7501-7507), as implemented by requirements of this part, are allowable. However, the following audit costs are unallowable:

(1) Any costs when audits required by the Single Audit Act and Subpart F—Audit Requirements of this part have not been conducted or have been conducted but not in accordance therewith; and

(2) Any costs of auditing a non-Federal entity that is exempted from having an audit conducted under the Single Audit Act and Subpart F—Audit Requirements of this part because its expenditures under Federal awards are less than \$750,000 during the non-Federal entity's fiscal year.

(b) The costs of a financial statement audit of a non-Federal entity that does not currently have a Federal award may be included in the indirect cost pool for a cost allocation plan or indirect cost proposal.

(c) Pass-through entities may charge Federal awards for the cost of agreed-upon-procedures engagements to monitor subrecipients (in accordance with Subpart D—Post Federal Award Requirements of this part, §§200.330 Subrecipient and contractor determinations through 200.332 Fixed Amount Subawards) who are exempted from the requirements of the Single Audit Act and Subpart F—Audit Requirements of this part. This cost is allowable only if the agreed-upon-procedures engagements are:

(1) Conducted in accordance with GAGAS attestation standards;

(2) Paid for and arranged by the pass-through entity; and

(3) Limited in scope to one or more of the following types of compliance requirements: activities allowed or unallowed; allowable costs/cost principles; eligibility; and reporting.

[↑ Back to Top](#)

§200.426 Bad debts.

Bad debts (debts which have been determined to be uncollectable), including losses (whether actual or estimated) arising from uncollectable accounts and other claims, are unallowable. Related collection costs, and related legal costs, arising from such debts after they have been determined to be uncollectable are also unallowable. See also §200.428 Collections of improper payments.

[↑ Back to Top](#)

§200.427 Bonding costs.

(a) Bonding costs arise when the Federal awarding agency requires assurance against financial loss to itself or others by reason of the act or default of the non-Federal entity. They arise also in instances where the non-Federal entity requires similar assurance, including: bonds as bid, performance, payment, advance payment, infringement, and fidelity bonds for employees and officials.

(b) Costs of bonding required pursuant to the terms and conditions of the Federal award are allowable.

(c) Costs of bonding required by the non-Federal entity in the general conduct of its operations are allowable as an indirect cost to the extent that such bonding is in accordance with sound business practice and the rates and premiums are reasonable under the circumstances.

[↑ Back to Top](#)

§200.428 Collections of improper payments.

The costs incurred by a non-Federal entity to recover improper payments are allowable as either direct or indirect costs, as appropriate. Amounts collected may be used by the non-Federal entity in accordance with cash management standards set forth in §200.305 *Payment*.

[↑ Back to Top](#)

§200.429 Commencement and convocation costs.

For IHEs, costs incurred for commencements and convocations are unallowable, except as provided for in Appendix III to Part 200—Indirect (F&A) Costs Identification and Assignment, and Rate Determination for Institutions of Higher Education (IHEs), paragraph (B)(9) Student Administration and Services, as student activity costs.

[↑ Back to Top](#)

§200.430 Compensation—personal services.

(a) *General.* Compensation for personal services includes all remuneration, paid currently or accrued, for services of employees rendered during the period of performance under the Federal award, including but not necessarily limited to wages and salaries. Compensation for personal services may also include fringe benefits which are addressed in §200.431 Compensation—fringe benefits. Costs of compensation are allowable to the extent that they satisfy the specific requirements of this part, and that the total compensation for individual employees:

(1) Is reasonable for the services rendered and conforms to the established written policy of the non-Federal entity consistently applied to both Federal and non-Federal activities;

(2) Follows an appointment made in accordance with a non-Federal entity's laws and/or rules or written policies and meets the requirements of Federal statute, where applicable; and

(3) Is determined and supported as provided in paragraph (i) of this section, Standards for Documentation of Personnel Expenses, when applicable.

(b) *Reasonableness.* Compensation for employees engaged in work on Federal awards will be considered reasonable to the extent that it is consistent with that paid for similar work in other activities of the non-Federal entity. In cases where the kinds of employees required for Federal awards are not found in the other activities of the non-Federal entity, compensation will be considered reasonable to the extent that it is comparable to that paid for similar work in the labor market in which the non-Federal entity competes for the kind of employees involved.

(c) *Professional activities outside the non-Federal entity.* Unless an arrangement is specifically authorized by a Federal awarding agency, a non-Federal entity must follow its written non-Federal entity-wide policies and practices concerning the permissible extent of professional services that can be provided outside the non-Federal entity for non-organizational compensation. Where such non-Federal entity-wide written policies do not exist or do not adequately define the permissible extent of consulting or other non-organizational activities undertaken for extra outside pay, the Federal Government may require that the effort of professional staff working on Federal awards be allocated between:

(1) Non-Federal entity activities, and

(2) Non-organizational professional activities. If the Federal awarding agency considers the extent of non-organizational professional effort excessive or inconsistent with the conflicts-of-interest terms and conditions of the Federal award, appropriate arrangements governing compensation will be negotiated on a case-by-case basis.

(d) *Unallowable costs.* (1) Costs which are unallowable under other sections of these principles must not be allowable under this section solely on the basis that they constitute personnel compensation.

(2) The allowable compensation for certain employees is subject to a ceiling in accordance with statute. For the amount of the ceiling for cost-reimbursement contracts, the covered compensation subject to the ceiling, the covered employees, and other relevant provisions, see 10 U.S.C. 2324(e)(1)(P), and 41 U.S.C. 1127 and 4304(a)(16). For other types of Federal awards, other statutory ceilings may apply.

(e) *Special considerations.* Special considerations in determining allowability of compensation will be given to any change in a non-Federal entity's compensation policy resulting in a substantial increase in its employees' level of compensation (particularly when the change was concurrent with an increase in the ratio of Federal awards to other activities) or any change in the treatment of allowability of specific types of compensation due to changes in Federal policy.

(f) *Incentive compensation.* Incentive compensation to employees based on cost reduction, or efficient performance, suggestion awards, safety awards, etc., is allowable to the extent that the overall compensation is determined to be reasonable and such costs are paid or accrued pursuant to an agreement entered into in good faith between the non-Federal entity and the employees before the services were rendered, or pursuant to an established plan followed by the non-Federal entity so consistently as to imply, in effect, an agreement to make such payment.

(g) *Nonprofit organizations.* For compensation to members of nonprofit organizations, trustees, directors, associates, officers, or the immediate families thereof, determination must be made that such compensation is reasonable for the actual personal services rendered rather than a distribution of earnings in excess of costs. This may include director's and executive committee member's fees, incentive awards, allowances for off-site pay, incentive pay, location allowances, hardship pay, and cost-of-living differentials.

(h) *Institutions of higher education (IHEs).* (1) Certain conditions require special consideration and possible limitations in determining allowable personnel compensation costs under Federal awards. Among such conditions are the following:

(i) Allowable activities. Charges to Federal awards may include reasonable amounts for activities contributing and directly related to work under an agreement, such as delivering special lectures about specific aspects of the ongoing activity, writing reports and articles, developing and maintaining protocols (human, animals, etc.), managing substances/chemicals, managing and securing project-specific data, coordinating research subjects, participating in appropriate seminars, consulting with colleagues and graduate students, and attending meetings and conferences.

(ii) Incidental activities. Incidental activities for which supplemental compensation is allowable under written institutional policy (at a rate not to exceed institutional base salary) need not be included in the records described in paragraph (i) of this section to directly charge payments of incidental activities, such activities must either be specifically provided for in the Federal award budget or receive prior written approval by the Federal awarding agency.

(2) *Salary basis.* Charges for work performed on Federal awards by faculty members during the academic year are allowable at the IBS rate. Except as noted in paragraph (h)(1)(ii) of this section, in no event will charges to Federal awards, irrespective of the basis of computation, exceed the proportionate share of the IBS for that period. This principle applies to all members of faculty at an institution. IBS is defined as the annual compensation paid by an IHE for an individual's appointment, whether that individual's time is spent on research, instruction, administration, or other activities. IBS excludes any income that an individual earns outside of duties performed for the IHE. Unless there is prior approval by the Federal awarding agency, charges of a faculty member's salary to a Federal award must not exceed the proportionate share of the IBS for the period during which the faculty member worked on the award.

(3) *Intra-Institution of Higher Education (IHE) consulting.* Intra-IHE consulting by faculty is assumed to be undertaken as an IHE obligation requiring no compensation in addition to IBS. However, in unusual cases where consultation is across departmental lines or involves a separate or remote operation, and the work performed by the faculty member is in addition to his or her regular responsibilities, any charges for such work representing additional compensation above IBS are allowable provided that such consulting arrangements are specifically provided for in the Federal award or approved in writing by the Federal awarding agency.

(4) Extra Service Pay normally represents overload compensation, subject to institutional compensation policies for services above and beyond IBS. Where extra service pay is a result of Intra-IHE consulting, it is subject to the same requirements of paragraph (b) above. It is allowable if all of the following conditions are met:

(i) The non-Federal entity establishes consistent written policies which apply uniformly to all faculty members, not just those working on Federal awards.

(ii) The non-Federal entity establishes a consistent written definition of work covered by IBS which is specific enough to determine conclusively when work beyond that level has occurred. This may be described in appointment letters or other documentations.

(iii) The supplementation amount paid is commensurate with the IBS rate of pay and the amount of additional work performed. See paragraph (h)(2) of this section.

(iv) The salaries, as supplemented, fall within the salary structure and pay ranges established by and documented in writing or otherwise applicable to the non-Federal entity.

(v) The total salaries charged to Federal awards including extra service pay are subject to the Standards of Documentation as described in paragraph (i) of this section.

(5) *Periods outside the academic year.* (i) Except as specified for teaching activity in paragraph (h)(5)(ii) of this section, charges for work performed by faculty members on Federal awards during periods not included in the base salary period will be at a rate not in excess of the IBS.

(ii) Charges for teaching activities performed by faculty members on Federal awards during periods not included in IBS period will be based on the normal written policy of the IHE governing compensation to faculty members for teaching assignments during such periods.

(6) *Part-time faculty.* Charges for work performed on Federal awards by faculty members having only part-time appointments will be determined at a rate not in excess of that regularly paid for part-time assignments.

(7) *Sabbatical leave costs.* Rules for sabbatical leave are as follow:

(i) Costs of leaves of absence by employees for performance of graduate work or sabbatical study, travel, or research are allowable provided the IHE has a uniform written policy on sabbatical leave for persons engaged in instruction and persons engaged in research. Such costs will be allocated on an equitable basis among all related activities of the IHE.

(ii) Where sabbatical leave is included in fringe benefits for which a cost is determined for assessment as a direct charge, the aggregate amount of such assessments applicable to all work of the institution during the base period must be reasonable in relation to the IHE's actual experience under its sabbatical leave policy.

(8) *Salary rates for non-faculty members.* Non-faculty full-time professional personnel may also earn "extra service pay" in accordance with the non-Federal entity's written policy and consistent with paragraph (h)(1)(i) of this section.

(i) *Standards for Documentation of Personnel Expenses* (1) Charges to Federal awards for salaries and wages must be based on records that accurately reflect the work performed. These records must:

(i) Be supported by a system of internal control which provides reasonable assurance that the charges are accurate, allowable, and properly allocated;

(ii) Be incorporated into the official records of the non-Federal entity;

(iii) Reasonably reflect the total activity for which the employee is compensated by the non-Federal entity, not exceeding 100% of compensated activities (for IHE, this per the IHE's definition of IBS);

(iv) Encompass both federally assisted and all other activities compensated by the non-Federal entity on an integrated basis, but may include the use of subsidiary records as defined in the non-Federal entity's written policy;

(v) Comply with the established accounting policies and practices of the non-Federal entity (See paragraph (h)(1)(ii) above for treatment of incidental work for IHEs.); and

(vi) [Reserved]

(vii) Support the distribution of the employee's salary or wages among specific activities or cost objectives if the employee works on more than one Federal award; a Federal award and non-Federal award; an indirect cost activity and a direct cost activity; two or more indirect activities which are allocated using different allocation bases; or an unallowable activity and a direct or indirect cost activity.

(viii) Budget estimates (i.e., estimates determined before the services are performed) alone do not qualify as support for charges to Federal awards, but may be used for interim accounting purposes, provided that:

(A) The system for establishing the estimates produces reasonable approximations of the activity actually performed;

(B) Significant changes in the corresponding work activity (as defined by the non-Federal entity's written policies) are identified and entered into the records in a timely manner. Short term (such as one or two months) fluctuation between workload categories need not be considered as long as the distribution of salaries and wages is reasonable over the longer term; and

(C) The non-Federal entity's system of internal controls includes processes to review after-the-fact interim charges made to a Federal award based on budget estimates. All necessary adjustment must be made such that the final amount charged to the Federal award is accurate, allowable, and properly allocated.

(ix) Because practices vary as to the activity constituting a full workload (for IHEs, IBS), records may reflect categories of activities expressed as a percentage distribution of total activities.

(x) It is recognized that teaching, research, service, and administration are often inextricably intermingled in an academic setting. When recording salaries and wages charged to Federal awards for IHEs, a precise assessment of factors that contribute to costs is therefore not always feasible, nor is it expected.

(2) For records which meet the standards required in paragraph (i)(1) of this section, the non-Federal entity will not be required to provide additional support or documentation for the work performed, other than that referenced in paragraph (i)(3) of this section.

(3) In accordance with Department of Labor regulations implementing the Fair Labor Standards Act (FLSA) (29 CFR part 516), charges for the salaries and wages of nonexempt employees, in addition to the supporting documentation described in this section, must also be supported by records indicating the total number of hours worked each day.

(4) Salaries and wages of employees used in meeting cost sharing or matching requirements on Federal awards must be supported in the same manner as salaries and wages claimed for reimbursement from Federal awards.

(5) For states, local governments and Indian tribes, substitute processes or systems for allocating salaries and wages to Federal awards may be used in place of or in addition to the records described in paragraph (1) if approved by the cognizant agency for indirect cost. Such systems may include, but are not limited to, random moment sampling, "rolling" time studies, case counts, or other quantifiable measures of work performed.

(i) Substitute systems which use sampling methods (primarily for Temporary Assistance for Needy Families (TANF), the Supplemental Nutrition Assistance Program (SNAP), Medicaid, and other public assistance programs) must meet acceptable statistical sampling standards including:

(A) The sampling universe must include all of the employees whose salaries and wages are to be allocated based on sample results except as provided in paragraph (i)(5)(iii) of this section;

(B) The entire time period involved must be covered by the sample; and

(C) The results must be statistically valid and applied to the period being sampled.

(ii) Allocating charges for the sampled employees' supervisors, clerical and support staffs, based on the results of the sampled employees, will be acceptable.

(iii) Less than full compliance with the statistical sampling standards noted in subsection (5)(i) may be accepted by the cognizant agency for indirect costs if it concludes that the amounts to be allocated to Federal awards will be minimal, or if it concludes that the system proposed by the non-Federal entity will result in lower costs to Federal awards than a system which complies with the standards.

(6) Cognizant agencies for indirect costs are encouraged to approve alternative proposals based on outcomes and milestones for program performance where these are clearly documented. Where approved by the Federal cognizant agency for indirect costs, these plans are acceptable as an alternative to the requirements of paragraph (i)(1) of this section.

(7) For Federal awards of similar purpose activity or instances of approved blended funding, a non-Federal entity may submit performance plans that incorporate funds from multiple Federal awards and account for their combined use based on performance-oriented metrics, provided that such plans are approved in advance by all involved Federal awarding agencies. In these instances, the non-Federal entity must submit a request for waiver of the requirements based on documentation that describes the method of charging costs, relates the charging of costs to the specific activity that is applicable to all fund sources, and is based on quantifiable measures of the activity in relation to time charged.

(8) For a non-Federal entity where the records do not meet the standards described in this section, the Federal Government may require personnel activity reports, including prescribed certifications, or equivalent documentation that support the records as required in this section.

[78 FR 78608, Dec. 26, 2013, as amended at 79 FR 75886, Dec. 19, 2014]

[↑ Back to Top](#)

§200.431 Compensation—fringe benefits.

(a) Fringe benefits are allowances and services provided by employers to their employees as compensation in addition to regular salaries and wages. Fringe benefits include, but are not limited to, the costs of leave (vacation, family-related, sick or military), employee insurance, pensions, and unemployment benefit plans. Except as provided elsewhere in these principles, the costs of fringe benefits are allowable provided that the benefits are reasonable and are required by law, non-Federal entity-employee agreement, or an established policy of the non-Federal entity.

(b) *Leave.* The cost of fringe benefits in the form of regular compensation paid to employees during periods of authorized absences from the job, such as for annual leave, family-related leave, sick leave, holidays, court leave, military leave, administrative leave, and other similar benefits, are allowable if all of the following criteria are met:

(1) They are provided under established written leave policies;

(2) The costs are equitably allocated to all related activities, including Federal awards; and,

(3) The accounting basis (cash or accrual) selected for costing each type of leave is consistently followed by the non-Federal entity or specified grouping of employees.

(i) When a non-Federal entity uses the cash basis of accounting, the cost of leave is recognized in the period that the leave is taken and paid for. Payments for unused leave when an employee retires or terminates employment are allowable in the year of payment.

(ii) The accrual basis may be only used for those types of leave for which a liability as defined by GAAP exists when the leave is earned. When a non-Federal entity uses the accrual basis of accounting, allowable leave costs are the lesser of the amount accrued or funded.

(c) The cost of fringe benefits in the form of employer contributions or expenses for social security; employee life, health, unemployment, and worker's compensation insurance (except as indicated in §200.447 Insurance and indemnification); pension plan costs (see paragraph (i) of this section); and other similar benefits are allowable, provided such benefits are granted under established written policies. Such benefits, must be allocated to Federal awards and all other activities in a manner consistent with the pattern of benefits attributable to the individuals or group(s) of employees whose salaries and wages are chargeable to such Federal awards and other activities, and charged as direct or indirect costs in accordance with the non-Federal entity's accounting practices.

(d) Fringe benefits may be assigned to cost objectives by identifying specific benefits to specific individual employees or by allocating on the basis of entity-wide salaries and wages of the employees receiving the benefits. When the allocation method is used, separate allocations must be made to selective groupings of employees, unless the non-Federal entity demonstrates that costs in relationship to salaries and wages do not differ significantly for different groups of employees.

(e) *Insurance.* See also §200.447 Insurance and indemnification, paragraphs (d)(1) and (2).

(1) Provisions for a reserve under a self-insurance program for unemployment compensation or workers' compensation are allowable to the extent that the provisions represent reasonable estimates of the liabilities for such compensation, and the types of coverage, extent of coverage, and rates and premiums would have been allowable had insurance been purchased to cover the risks. However, provisions for self-insured liabilities which do not become payable for more than one year after the provision is made must not exceed the present value of the liability.

(2) Costs of insurance on the lives of trustees, officers, or other employees holding positions of similar responsibility are allowable only to the extent that the insurance represents additional compensation. The costs of such insurance when the non-Federal entity is named as beneficiary are unallowable.

(3) Actual claims paid to or on behalf of employees or former employees for workers' compensation, unemployment compensation, severance pay, and similar employee benefits (e.g., post-retirement health benefits), are allowable in the year of payment provided that the non-Federal entity follows a consistent costing policy.

(f) *Automobiles.* That portion of automobile costs furnished by the entity that relates to personal use by employees (including transportation to and from work) is unallowable as fringe benefit or indirect (F&A) costs regardless of whether the cost is reported as taxable income to the employees.

(g) *Pension Plan Costs.* Pension plan costs which are incurred in accordance with the established policies of the non-Federal entity are allowable, provided that:

(1) Such policies meet the test of reasonableness.

(2) The methods of cost allocation are not discriminatory.

(3) For entities using accrual based accounting, the cost assigned to each fiscal year is determined in accordance with GAAP.

(4) The costs assigned to a given fiscal year are funded for all plan participants within six months after the end of that year. However, increases to normal and past service pension costs caused by a delay in funding the actuarial liability beyond 30 calendar days after each quarter of the year to which such costs are assignable are unallowable. Non-Federal entity may elect to follow the "Cost Accounting Standard for Composition and Measurement of Pension Costs" (48 CFR 9904.412).

(5) Pension plan termination insurance premiums paid pursuant to the Employee Retirement Income Security Act (ERISA) of 1974 (29 U.S.C. 1301-1461) are allowable. Late payment charges on such premiums are unallowable. Excise taxes on accumulated funding deficiencies and other penalties imposed under ERISA are unallowable.

(6) Pension plan costs may be computed using a pay-as-you-go method or an acceptable actuarial cost method in accordance with established written policies of the non-Federal entity.

(i) For pension plans financed on a pay-as-you-go method, allowable costs will be limited to those representing actual payments to retirees or their beneficiaries.

(ii) Pension costs calculated using an actuarial cost-based method recognized by GAAP are allowable for a given fiscal year if they are funded for that year within six months after the end of that year. Costs funded after the six month period (or a later period agreed to by the cognizant agency for indirect costs) are allowable in the year funded. The cognizant agency for indirect costs may agree to an extension of the six month period if an appropriate adjustment is made to compensate for the timing of the charges to the Federal Government and related Federal reimbursement and the non-Federal entity's contribution to the pension fund. Adjustments may be made by cash refund or other equitable procedures to compensate the Federal Government for the time value of Federal reimbursements in excess of contributions to the pension fund.

(iii) Amounts funded by the non-Federal entity in excess of the actuarially determined amount for a fiscal year may be used as the non-Federal entity's contribution in future periods.

(iv) When a non-Federal entity converts to an acceptable actuarial cost method, as defined by GAAP, and funds pension costs in accordance with this method, the unfunded liability at the time of conversion is allowable if amortized over a period of years in accordance with GAAP.

(v) The Federal Government must receive an equitable share of any previously allowed pension costs (including earnings thereon) which revert or inure to the non-Federal entity in the form of a refund, withdrawal, or other credit.

(h) *Post-Retirement Health*. Post-retirement health plans (PRHP) refers to costs of health insurance or health services not included in a pension plan covered by paragraph (g) of this section for retirees and their spouses, dependents, and survivors. PRHP costs may be computed using a pay-as-you-go method or an acceptable actuarial cost method in accordance with established written policies of the non-Federal entity.

(1) For PRHP financed on a pay-as-you-go method, allowable costs will be limited to those representing actual payments to retirees or their beneficiaries.

(2) PRHP costs calculated using an actuarial cost method recognized by GAAP are allowable if they are funded for that year within six months after the end of that year. Costs funded after the six month period (or a later period agreed to by the cognizant agency) are allowable in the year funded. The Federal cognizant agency for indirect costs may agree to an extension of the six month period if an appropriate adjustment is made to compensate for the timing of the charges to the Federal Government and related Federal reimbursements and the non-Federal entity's contributions to the PRHP fund. Adjustments may be made by cash refund, reduction in current year's PRHP costs, or other equitable procedures to compensate the Federal Government for the time value of Federal reimbursements in excess of contributions to the PRHP fund.

(3) Amounts funded in excess of the actuarially determined amount for a fiscal year may be used as the Federal Government's contribution in a future period.

(4) When a non-Federal entity converts to an acceptable actuarial cost method and funds PRHP costs in accordance with this method, the initial unfunded liability attributable to prior years is allowable if amortized over a period of years in accordance with GAAP, or, if no such GAAP period exists, over a period negotiated with the cognizant agency for indirect costs.

(5) To be allowable in the current year, the PRHP costs must be paid either to:

(i) An insurer or other benefit provider as current year costs or premiums, or

(ii) An insurer or trustee to maintain a trust fund or reserve for the sole purpose of providing post-retirement benefits to retirees and other beneficiaries.

(6) The Federal Government must receive an equitable share of any amounts of previously allowed post-retirement benefit costs (including earnings thereon) which revert or inure to the non-Federal entity in the form of a refund, withdrawal, or other credit.

(i) *Severance Pay*. (1) Severance pay, also commonly referred to as dismissal wages, is a payment in addition to regular salaries and wages, by non-Federal entities to workers whose employment is being terminated. Costs of severance pay are allowable only to the extent that in each case, it is required by (a) law, (b) employer-employee agreement, (c) established policy that constitutes, in effect, an implied agreement on the non-Federal entity's part, or (d) circumstances of the particular employment.

(2) Costs of severance payments are divided into two categories as follows:

(i) Actual normal turnover severance payments must be allocated to all activities; or, where the non-Federal entity provides for a reserve for normal severances, such method will be acceptable if the charge to current operations is reasonable in light of payments actually made for normal severances over a representative past period, and if amounts charged are allocated to all activities of the non-Federal entity.

(ii) Measurement of costs of abnormal or mass severance pay by means of an accrual will not achieve equity to both parties. Thus, accruals for this purpose are not allowable. However, the Federal Government recognizes its obligation to participate, to the extent of its fair share, in any specific payment. Prior approval by the Federal awarding agency or cognizant agency for indirect cost, as appropriate, is required.

(3) Costs incurred in certain severance pay packages which are in an amount in excess of the normal severance pay paid by the non-Federal entity to an employee upon termination of employment and are paid to the employee contingent upon a change in management control over, or ownership of, the non-Federal entity's assets, are unallowable.

(4) Severance payments to foreign nationals employed by the non-Federal entity outside the United States, to the extent that the amount exceeds the customary or prevailing practices for the non-Federal entity in the United States, are unallowable, unless they are necessary for the performance of Federal programs and approved by the Federal awarding agency.

(5) Severance payments to foreign nationals employed by the non-Federal entity outside the United States due to the termination of the foreign national as a result of the closing of, or curtailment of activities by, the non-Federal entity in that country, are unallowable, unless they are necessary for the performance of Federal programs and approved by the Federal awarding agency.

(j)(1) *For IHEs only.* Fringe benefits in the form of tuition or remission of tuition for individual employees are allowable, provided such benefits are granted in accordance with established non-Federal entity policies, and are distributed to all non-Federal entity activities on an equitable basis. Tuition benefits for family members other than the employee are unallowable.

(2) Fringe benefits in the form of tuition or remission of tuition for individual employees not employed by IHEs are limited to the tax-free amount allowed per section 127 of the Internal Revenue Code as amended.

(3) IHEs may offer employees tuition waivers or tuition reductions for undergraduate education under IRC Section 117(d) as amended, provided that the benefit does not discriminate in favor of highly compensated employees. Federal reimbursement of tuition or remission of tuition is also limited to the institution for which the employee works. See §200.466 Scholarships and student aid costs, for treatment of tuition remission provided to students.

(k) For IHEs whose costs are paid by state or local governments, fringe benefit programs (such as pension costs and FICA) and any other benefits costs specifically incurred on behalf of, and in direct benefit to, the non-Federal entity, are allowable costs of such non-Federal entities whether or not these costs are recorded in the accounting records of the non-Federal entities, subject to the following:

(1) The costs meet the requirements of Basic Considerations in §§200.402 Composition of costs through 200.411 Adjustment of previously negotiated indirect (F&A) cost rates containing unallowable costs of this subpart;

(2) The costs are properly supported by approved cost allocation plans in accordance with applicable Federal cost accounting principles; and

(3) The costs are not otherwise borne directly or indirectly by the Federal Government.

[78 FR 78608, Dec. 26, 2013, as amended at 79 FR 75886, Dec. 19, 2014]

[↑ Back to Top](#)

§200.432 Conferences.

A conference is defined as a meeting, retreat, seminar, symposium, workshop or event whose primary purpose is the dissemination of technical information beyond the non-Federal entity and is necessary and reasonable for successful performance under the Federal award. Allowable conference costs paid by the non-Federal entity as a sponsor or host of the conference may include rental of facilities, speakers' fees, costs of meals and refreshments, local transportation, and other items incidental to such conferences unless further restricted by the terms and conditions of the Federal award. As needed, the costs of identifying, but not providing, locally available dependent-care resources are allowable. Conference hosts/sponsors must exercise discretion and judgment in ensuring that conference costs are appropriate, necessary and managed in a manner that minimizes costs to the Federal award. The Federal awarding agency may authorize exceptions where appropriate for programs including Indian tribes, children, and the elderly. See also §§200.438 Entertainment costs, 200.456 Participant support costs, 200.474 Travel costs, and 200.475 Trustees.

[↑ Back to Top](#)

§200.433 Contingency provisions.

(a) Contingency is that part of a budget estimate of future costs (typically of large construction projects, IT systems, or other items as approved by the Federal awarding agency) which is associated with possible events or conditions arising from causes the precise outcome of which is indeterminable at the time of estimate, and that experience shows will likely result, in aggregate, in additional costs for the approved activity or project. Amounts for major project scope changes, unforeseen risks, or extraordinary events may not be included.

(b) It is permissible for contingency amounts other than those excluded in paragraph (a) of this section to be explicitly included in budget estimates, to the extent they are necessary to improve the precision of those estimates. Amounts must be estimated using broadly-accepted cost estimating methodologies, specified in the budget documentation of the Federal award, and accepted by the Federal awarding agency. As such, contingency amounts are to be included in the Federal award. In order for actual costs incurred to be allowable, they must comply with the cost principles and other requirements in this part (see also §§200.300 Statutory and national policy requirements through 200.309 Period of performance of Subpart D of this part and 200.403 Factors affecting allowability of costs); be necessary and reasonable for proper and efficient accomplishment of project or program objectives, and be verifiable from the non-Federal entity's records.

(c) Payments made by the Federal awarding agency to the non-Federal entity's "contingency reserve" or any similar payment made for events the occurrence of which cannot be foretold with certainty as to the time or intensity, or with an assurance of their happening, are unallowable, except as noted in §§200.431 Compensation—fringe benefits regarding self-insurance, pensions, severance and post-retirement health costs and 200.447 Insurance and indemnification.

[78 FR 78608, Dec. 26, 2013, as amended at 79 FR 75886, Dec. 19, 2014]

[↑ Back to Top](#)

§200.434 Contributions and donations.

(a) Costs of contributions and donations, including cash, property, and services, from the non-Federal entity to other entities, are unallowable.

(b) The value of services and property donated to the non-Federal entity may not be charged to the Federal award either as a direct or indirect (F&A) cost. The value of donated services and property may be used to meet cost sharing or matching requirements (see §200.306 Cost sharing or matching). Depreciation on donated assets is permitted in accordance with §200.436 Depreciation, as long as the donated property is not counted towards cost sharing or matching requirements.

(c) Services donated or volunteered to the non-Federal entity may be furnished to a non-Federal entity by professional and technical personnel, consultants, and other skilled and unskilled labor. The value of these services may not be charged to the Federal award either as a direct or indirect cost. However, the value of donated services may be used to meet cost sharing or matching requirements in accordance with the provisions of §200.306 Cost sharing or matching.

(d) To the extent feasible, services donated to the non-Federal entity will be supported by the same methods used to support the allocability of regular personnel services.

(e) The following provisions apply to nonprofit organizations. The value of services donated to the nonprofit organization utilized in the performance of a direct cost activity must be considered in the determination of the non-Federal entity's indirect cost rate(s) and, accordingly, must be allocated a proportionate share of applicable indirect costs when the following circumstances exist:

(1) The aggregate value of the services is material;

(2) The services are supported by a significant amount of the indirect costs incurred by the non-Federal entity;

(i) In those instances where there is no basis for determining the fair market value of the services rendered, the non-Federal entity and the cognizant agency for indirect costs must negotiate an appropriate allocation of indirect cost to the services.

(ii) Where donated services directly benefit a project supported by the Federal award, the indirect costs allocated to the services will be considered as a part of the total costs of the project. Such indirect costs may be reimbursed under the Federal award or used to meet cost sharing or matching requirements.

(f) Fair market value of donated services must be computed as described in §200.306 Cost sharing or matching.

(g) Personal Property and Use of Space.

(1) Donated personal property and use of space may be furnished to a non-Federal entity. The value of the personal property and space may not be charged to the Federal award either as a direct or indirect cost.

(2) The value of the donations may be used to meet cost sharing or matching share requirements under the conditions described in §§200.300 Statutory and national policy requirements through 200.309 Period of performance of subpart D of this part. The value of the donations must be determined in accordance with §§200.300 Statutory and national policy requirements through 200.309 Period of performance. Where donations are treated as indirect costs, indirect cost rates will separate the value of the donations so that reimbursement will not be made.

[78 FR 78608, Dec. 26, 2013, as amended at 79 FR 75886, Dec. 19, 2014]

[↑ Back to Top](#)

§200.435 Defense and prosecution of criminal and civil proceedings, claims, appeals and patent infringements.

(a) Definitions for the purposes of this section.

(1) *Conviction* means a judgment or conviction of a criminal offense by any court of competent jurisdiction, whether entered upon verdict or a plea, including a conviction due to a plea of nolo contendere.

(2) *Costs* include the services of in-house or private counsel, accountants, consultants, or others engaged to assist the non-Federal entity before, during, and after commencement of a judicial or administrative proceeding, that bear a direct relationship to the proceeding.

(3) *Fraud* means:

(i) Acts of fraud or corruption or attempts to defraud the Federal Government or to corrupt its agents,

(ii) Acts that constitute a cause for debarment or suspension (as specified in agency regulations), and

(iii) Acts which violate the False Claims Act (31 U.S.C. 3729-3732) or the Anti-kickback Act (41 U.S.C. 1320a-7b(b)).

(4) *Penalty* does not include restitution, reimbursement, or compensatory damages.

(5) *Proceeding* includes an investigation.

(b) *Costs*. (1) Except as otherwise described herein, costs incurred in connection with any criminal, civil or administrative proceeding (including filing of a false certification) commenced by the Federal Government, a state, local government, or foreign government, or joined by the Federal Government (including a proceeding under the False Claims Act), against the non-Federal entity, (or commenced by third parties or a current or former employee of the non-Federal entity who submits a whistleblower complaint of reprisal in accordance with 10 U.S.C. 2409 or 41 U.S.C. 4712), are not allowable if the proceeding:

(i) Relates to a violation of, or failure to comply with, a Federal, state, local or foreign statute, regulation or the terms and conditions of the Federal award, by the non-Federal entity (including its agents and employees); and

(ii) Results in any of the following dispositions:

(A) In a criminal proceeding, a conviction.

(B) In a civil or administrative proceeding involving an allegation of fraud or similar misconduct, a determination of non-Federal entity liability.

(C) In the case of any civil or administrative proceeding, the disallowance of costs or the imposition of a monetary penalty, or an order issued by the Federal awarding agency head or delegate to the non-Federal entity to take corrective action under 10 U.S.C. 2409 or 41 U.S.C. 4712.

(D) A final decision by an appropriate Federal official to debar or suspend the non-Federal entity, to rescind or void a Federal award, or to terminate a Federal award by reason of a violation or failure to comply with a statute, regulation, or the terms and conditions of the Federal award.

(E) A disposition by consent or compromise, if the action could have resulted in any of the dispositions described in paragraphs (b)(1)(ii)(A) through (D) of this section.

(2) If more than one proceeding involves the same alleged misconduct, the costs of all such proceedings are unallowable if any results in one of the dispositions shown in paragraph (b) of this section.

(c) If a proceeding referred to in paragraph (b) of this section is commenced by the Federal Government and is resolved by consent or compromise pursuant to an agreement by the non-Federal entity and the Federal Government, then the costs incurred may be allowed to the extent specifically provided in such agreement.

(d) If a proceeding referred to in paragraph (b) of this section is commenced by a state, local or foreign government, the authorized Federal official may allow the costs incurred if such authorized official determines that the costs were incurred as a result of:

(1) A specific term or condition of the Federal award, or

(2) Specific written direction of an authorized official of the Federal awarding agency.

(e) Costs incurred in connection with proceedings described in paragraph (b) of this section, which are not made unallowable by that subsection, may be allowed but only to the extent that:

(1) The costs are reasonable and necessary in relation to the administration of the Federal award and activities required to deal with the proceeding and the underlying cause of action;

(2) Payment of the reasonable, necessary, allocable and otherwise allowable costs incurred is not prohibited by any other provision(s) of the Federal award;

(3) The costs are not recovered from the Federal Government or a third party, either directly as a result of the proceeding or otherwise; and,

(4) An authorized Federal official must determine the percentage of costs allowed considering the complexity of litigation, generally accepted principles governing the award of legal fees in civil actions involving the United States, and such other factors as may be appropriate. Such percentage must not exceed 80 percent. However, if an agreement reached under paragraph (c) of this section has explicitly considered this 80 percent limitation and permitted a higher percentage, then the full amount of costs resulting from that agreement are allowable.

(f) Costs incurred by the non-Federal entity in connection with the defense of suits brought by its employees or ex-employees under section 2 of the Major Fraud Act of 1988 (18 U.S.C. 1031), including the cost of all relief necessary to make such employee whole, where the non-Federal entity was found liable or settled, are unallowable.

(g) Costs of prosecution of claims against the Federal Government, including appeals of final Federal agency decisions, are unallowable.

(h) Costs of legal, accounting, and consultant services, and related costs, incurred in connection with patent infringement litigation, are unallowable unless otherwise provided for in the Federal award.

(i) Costs which may be unallowable under this section, including directly associated costs, must be segregated and accounted for separately. During the pendency of any proceeding covered by paragraphs (b) and (f) of this section, the Federal Government must generally withhold payment of such costs. However, if in its best interests, the Federal Government may provide for conditional payment upon provision of adequate security, or other adequate assurance, and agreement to repay all unallowable costs, plus interest, if the costs are subsequently determined to be unallowable.

[78 FR 78608, Dec. 26, 2013, as amended at 79 FR 75886, Dec. 19, 2014]

[↑ Back to Top](#)

§200.436 Depreciation.

(a) Depreciation is the method for allocating the cost of fixed assets to periods benefitting from asset use. The non-Federal entity may be compensated for the use of its buildings, capital improvements, equipment, and software projects capitalized in accordance with GAAP, provided that they are used, needed in the non-Federal entity's activities, and properly allocated to Federal awards. Such compensation must be made by computing depreciation.

(b) The allocation for depreciation must be made in accordance with Appendices III through IX.

(c) Depreciation is computed applying the following rules. The computation of depreciation must be based on the acquisition cost of the assets involved. For an asset donated to the non-Federal entity by a third party, its fair market value at the time of the donation must be considered as the acquisition cost. Such assets may be depreciated or claimed as matching but not both. For the purpose of computing depreciation, the acquisition cost will exclude:

(1) The cost of land;

(2) Any portion of the cost of buildings and equipment borne by or donated by the Federal Government, irrespective of where title was originally vested or where it is presently located;

(3) Any portion of the cost of buildings and equipment contributed by or for the non-Federal entity where law or agreement prohibits recovery; and

(4) Any asset acquired solely for the performance of a non-Federal award.

(d) When computing depreciation charges, the following must be observed:

(1) The period of useful service or useful life established in each case for usable capital assets must take into consideration such factors as type of construction, nature of the equipment, technological developments in the particular area, historical data, and the renewal and replacement policies followed for the individual items or classes of assets involved.

(2) The depreciation method used to charge the cost of an asset (or group of assets) to accounting periods must reflect the pattern of consumption of the asset during its useful life. In the absence of clear evidence indicating that the expected consumption of the asset will be significantly greater in the early portions than in the later portions of its useful life, the straight-line method must be presumed to be the appropriate method. Depreciation methods once used may not be changed unless approved in advance by the cognizant agency. The depreciation methods used to calculate the depreciation amounts for indirect (F&A) rate purposes must be the same methods used by the non-Federal entity for its financial statements.

(3) The entire building, including the shell and all components, may be treated as a single asset and depreciated over a single useful life. A building may also be divided into multiple components. Each component item may then be depreciated over its estimated useful life. The building components must be grouped into three general components of a building: building shell (including construction and design costs), building services systems (e.g., elevators, HVAC, plumbing system and heating and air-conditioning system) and fixed equipment (e.g., sterilizers, casework, fume hoods, cold rooms and glassware/washers). In exceptional cases, a cognizant agency may authorize a non-Federal entity to use more than these three groupings. When a non-Federal entity elects to depreciate its buildings by its components, the same depreciation methods must be used for indirect (F&A) purposes and financial statements purposes, as described in paragraphs (d)(1) and (2) of this section.

(4) No depreciation may be allowed on any assets that have outlived their depreciable lives.

(5) Where the depreciation method is introduced to replace the use allowance method, depreciation must be computed as if the asset had been depreciated over its entire life (i.e., from the date the asset was acquired and ready for use to the date of disposal or withdrawal from service). The total amount of use allowance and depreciation for an asset (including imputed depreciation applicable to periods prior to the conversion from the use allowance method as well as depreciation after the conversion) may not exceed the total acquisition cost of the asset.

(e) Charges for depreciation must be supported by adequate property records, and physical inventories must be taken at least once every two years to ensure that the assets exist and are usable, used, and needed. Statistical sampling techniques may be used in taking these inventories. In addition, adequate depreciation records showing the amount of depreciation taken each period must also be maintained.

[78 FR 78608, Dec. 26, 2013, as amended at 79 FR 75886, Dec. 19, 2014]

[↑ Back to Top](#)

§200.437 Employee health and welfare costs.

(a) Costs incurred in accordance with the non-Federal entity's documented policies for the improvement of working conditions, employer-employee relations, employee health, and employee performance are allowable.

(b) Such costs will be equitably apportioned to all activities of the non-Federal entity. Income generated from any of these activities will be credited to the cost thereof unless such income has been irrevocably sent to employee welfare organizations.

(c) Losses resulting from operating food services are allowable only if the non-Federal entity's objective is to operate such services on a break-even basis. Losses sustained because of operating objectives other than the above are allowable only:

- (1) Where the non-Federal entity can demonstrate unusual circumstances; and
- (2) With the approval of the cognizant agency for indirect costs.

[↑ Back to Top](#)

§200.438 Entertainment costs.

Costs of entertainment, including amusement, diversion, and social activities and any associated costs are unallowable, except where specific costs that might otherwise be considered entertainment have a programmatic purpose and are authorized either in the approved budget for the Federal award or with prior written approval of the Federal awarding agency.

[↑ Back to Top](#)

§200.439 Equipment and other capital expenditures.

(a) See §§200.13 Capital expenditures, 200.33 Equipment, 200.89 Special purpose equipment, 200.48 General purpose equipment, 200.2 Acquisition cost, and 200.12 Capital assets.

(b) The following rules of allowability must apply to equipment and other capital expenditures:

(1) Capital expenditures for general purpose equipment, buildings, and land are unallowable as direct charges, except with the prior written approval of the Federal awarding agency or pass-through entity.

(2) Capital expenditures for special purpose equipment are allowable as direct costs, provided that items with a unit cost of \$5,000 or more have the prior written approval of the Federal awarding agency or pass-through entity.

(3) Capital expenditures for improvements to land, buildings, or equipment which materially increase their value or useful life are unallowable as a direct cost except with the prior written approval of the Federal awarding agency, or pass-through entity. See §200.436 Depreciation, for rules on the allowability of depreciation on buildings, capital improvements, and equipment. See also §200.465 Rental costs of real property and equipment.

(4) When approved as a direct charge pursuant to paragraphs (b)(1) through (3) of this section, capital expenditures will be charged in the period in which the expenditure is incurred, or as otherwise determined appropriate and negotiated with the Federal awarding agency.

(5) The unamortized portion of any equipment written off as a result of a change in capitalization levels may be recovered by continuing to claim the otherwise allowable depreciation on the equipment, or by amortizing the amount to be written off over a period of years negotiated with the Federal cognizant agency for indirect cost.

(6) Cost of equipment disposal. If the non-Federal entity is instructed by the Federal awarding agency to otherwise dispose of or transfer the equipment the costs of such disposal or transfer are allowable.

(7) Equipment and other capital expenditures are unallowable as indirect costs. See §200.436 Depreciation.

[78 FR 78608, Dec. 26, 2013, as amended at 79 FR 75886, Dec. 19, 2014]

[↑ Back to Top](#)

§200.440 Exchange rates.

(a) Cost increases for fluctuations in exchange rates are allowable costs subject to the availability of funding. Prior approval of exchange rate fluctuations is required only when the change results in the need for additional Federal funding, or the increased costs result in the need to significantly reduce the scope of the project. The Federal awarding agency must however ensure that adequate funds are available to cover currency fluctuations in order to avoid a violation of the Anti-Deficiency Act.

(b) The non-Federal entity is required to make reviews of local currency gains to determine the need for additional federal funding before the expiration date of the Federal award. Subsequent adjustments for currency increases may be allowable only when the non-Federal entity provides the Federal awarding agency with adequate source documentation from a commonly used source in effect at the time the expense was made, and to the extent that sufficient Federal funds are available.

[78 FR 78608, Dec. 26, 2013, as amended at 79 FR 75886, Dec. 19, 2014]

[↑ Back to Top](#)

§200.441 Fines, penalties, damages and other settlements.

Costs resulting from non-Federal entity violations of, alleged violations of, or failure to comply with, Federal, state, tribal, local or foreign laws and regulations are unallowable, except when incurred as a result of compliance with specific provisions of the Federal award, or with prior written approval of the Federal awarding agency. See also §200.435 Defense and prosecution of criminal and civil proceedings, claims, appeals and patent infringements.

[↑ Back to Top](#)

§200.442 Fund raising and investment management costs.

(a) Costs of organized fund raising, including financial campaigns, endowment drives, solicitation of gifts and bequests, and similar expenses incurred to raise capital or obtain contributions are unallowable. Fund raising costs for the purposes of meeting the Federal program objectives are allowable with prior written approval from the Federal awarding agency. Proposal costs are covered in §200.460 Proposal costs.

(b) Costs of investment counsel and staff and similar expenses incurred to enhance income from investments are unallowable except when associated with investments covering pension, self-insurance, or other funds which include Federal participation allowed by this part.

(c) Costs related to the physical custody and control of monies and securities are allowable.

(d) Both allowable and unallowable fund raising and investment activities must be allocated as an appropriate share of indirect costs under the conditions described in §200.413 Direct costs.

[↑ Back to Top](#)

§200.443 Gains and losses on disposition of depreciable assets.

(a) Gains and losses on the sale, retirement, or other disposition of depreciable property must be included in the year in which they occur as credits or charges to the asset cost grouping(s) in which the property was included. The amount of the gain or loss to be included as a credit or charge to the appropriate asset cost grouping(s) is the difference between the amount realized on the property and the undepreciated basis of the property.

(b) Gains and losses from the disposition of depreciable property must not be recognized as a separate credit or charge under the following conditions:

(1) The gain or loss is processed through a depreciation account and is reflected in the depreciation allowable under §§200.436 Depreciation and 200.439 Equipment and other capital expenditures.

(2) The property is given in exchange as part of the purchase price of a similar item and the gain or loss is taken into account in determining the depreciation cost basis of the new item.

(3) A loss results from the failure to maintain permissible insurance, except as otherwise provided in §200.447 Insurance and indemnification.

(4) Compensation for the use of the property was provided through use allowances in lieu of depreciation.

(5) Gains and losses arising from mass or extraordinary sales, retirements, or other dispositions must be considered on a case-by-case basis.

(c) Gains or losses of any nature arising from the sale or exchange of property other than the property covered in paragraph (a) of this section, e.g., land, must be excluded in computing Federal award costs.

(d) When assets acquired with Federal funds, in part or wholly, are disposed of, the distribution of the proceeds must be made in accordance with §§200.310 Insurance Coverage through 200.316 Property trust relationship.

[78 FR 78608, Dec. 26, 2013, as amended at 79 FR 75886, Dec. 19, 2014]

[↑ Back to Top](#)

§200.444 General costs of government.

(a) For states, local governments, and Indian Tribes, the general costs of government are unallowable (except as provided in §200.474 Travel costs). Unallowable costs include:

(1) Salaries and expenses of the Office of the Governor of a state or the chief executive of a local government or the chief executive of an Indian tribe;

(2) Salaries and other expenses of a state legislature, tribal council, or similar local governmental body, such as a county supervisor, city council, school board, etc., whether incurred for purposes of legislation or executive direction;

(3) Costs of the judicial branch of a government;

(4) Costs of prosecutorial activities unless treated as a direct cost to a specific program if authorized by statute or regulation (however, this does not preclude the allowability of other legal activities of the Attorney General as described in §200.435 Defense and prosecution of criminal and civil proceedings, claims, appeals and patent infringements); and

(5) Costs of other general types of government services normally provided to the general public, such as fire and police, unless provided for as a direct cost under a program statute or regulation.

(b) For Indian tribes and Councils of Governments (COGs) (see §200.64 Local government), up to 50% of salaries and expenses directly attributable to managing and operating Federal programs by the chief executive and his or her staff can be included in the indirect cost calculation without documentation.

[78 FR 78608, Dec. 26, 2013, as amended at 79 FR 75886, Dec. 19, 2014]

[↑ Back to Top](#)

§200.445 Goods or services for personal use.

(a) Costs of goods or services for personal use of the non-Federal entity's employees are unallowable regardless of whether the cost is reported as taxable income to the employees.

(b) Costs of housing (e.g., depreciation, maintenance, utilities, furnishings, rent), housing allowances and personal living expenses are only allowable as direct costs regardless of whether reported as taxable income to the employees. In addition, to be allowable direct costs must be approved in advance by a Federal awarding agency.

[↑ Back to Top](#)

§200.446 Idle facilities and idle capacity.

(a) As used in this section the following terms have the meanings set forth in this section:

(1) Facilities means land and buildings or any portion thereof, equipment individually or collectively, or any other tangible capital asset, wherever located, and whether owned or leased by the non-Federal entity.

(2) Idle facilities means completely unused facilities that are excess to the non-Federal entity's current needs.

(3) Idle capacity means the unused capacity of partially used facilities. It is the difference between:

(i) That which a facility could achieve under 100 percent operating time on a one-shift basis less operating interruptions resulting from time lost for repairs, setups, unsatisfactory materials, and other normal delays and;

(ii) The extent to which the facility was actually used to meet demands during the accounting period. A multi-shift basis should be used if it can be shown that this amount of usage would normally be expected for the type of facility involved.

(4) Cost of idle facilities or idle capacity means costs such as maintenance, repair, housing, rent, and other related costs, e.g., insurance, interest, and depreciation. These costs could include the costs of idle public safety emergency facilities, telecommunications, or information technology system capacity that is built to withstand major fluctuations in load, e.g., consolidated data centers.

(b) The costs of idle facilities are unallowable except to the extent that:

(1) They are necessary to meet workload requirements which may fluctuate and are allocated appropriately to all benefiting programs; or

(2) Although not necessary to meet fluctuations in workload, they were necessary when acquired and are now idle because of changes in program requirements, efforts to achieve more economical operations, reorganization, termination, or other causes which could not have been reasonably foreseen. Under the exception stated in this subsection, costs of idle facilities are allowable for a reasonable period of time, ordinarily not to exceed one year, depending on the initiative taken to use, lease, or dispose of such facilities.

(c) The costs of idle capacity are normal costs of doing business and are a factor in the normal fluctuations of usage or indirect cost rates from period to period. Such costs are allowable, provided that the capacity is reasonably anticipated to be necessary to carry out the purpose of the Federal award or was originally reasonable and is not subject to reduction or elimination by use on other Federal awards, subletting, renting, or sale, in accordance with sound business, economic, or security practices. Widespread idle capacity throughout an entire facility or among a group of assets having substantially the same function may be considered idle facilities.

[↑ Back to Top](#)

§200.447 Insurance and indemnification.

(a) Costs of insurance required or approved and maintained, pursuant to the Federal award, are allowable.

(b) Costs of other insurance in connection with the general conduct of activities are allowable subject to the following limitations:

- (1) Types and extent and cost of coverage are in accordance with the non-Federal entity's policy and sound business practice.
- (2) Costs of insurance or of contributions to any reserve covering the risk of loss of, or damage to, Federal Government property are unallowable except to the extent that the Federal awarding agency has specifically required or approved such costs.
- (3) Costs allowed for business interruption or other similar insurance must exclude coverage of management fees.
- (4) Costs of insurance on the lives of trustees, officers, or other employees holding positions of similar responsibilities are allowable only to the extent that the insurance represents additional compensation (see §200.431 Compensation—fringe benefits). The cost of such insurance when the non-Federal entity is identified as the beneficiary is unallowable.
- (5) Insurance against defects. Costs of insurance with respect to any costs incurred to correct defects in the non-Federal entity's materials or workmanship are unallowable.
- (6) Medical liability (malpractice) insurance. Medical liability insurance is an allowable cost of Federal research programs only to the extent that the Federal research programs involve human subjects or training of participants in research techniques. Medical liability insurance costs must be treated as a direct cost and must be assigned to individual projects based on the manner in which the insurer allocates the risk to the population covered by the insurance.
- (c) Actual losses which could have been covered by permissible insurance (through a self-insurance program or otherwise) are unallowable, unless expressly provided for in the Federal award. However, costs incurred because of losses not covered under nominal deductible insurance coverage provided in keeping with sound management practice, and minor losses not covered by insurance, such as spoilage, breakage, and disappearance of small hand tools, which occur in the ordinary course of operations, are allowable.
- (d) Contributions to a reserve for certain self-insurance programs including workers' compensation, unemployment compensation, and severance pay are allowable subject to the following provisions:
- (1) The type of coverage and the extent of coverage and the rates and premiums would have been allowed had insurance (including reinsurance) been purchased to cover the risks. However, provision for known or reasonably estimated self-insured liabilities, which do not become payable for more than one year after the provision is made, must not exceed the discounted present value of the liability. The rate used for discounting the liability must be determined by giving consideration to such factors as the non-Federal entity's settlement rate for those liabilities and its investment rate of return.
- (2) Earnings or investment income on reserves must be credited to those reserves.
- (3)(i) Contributions to reserves must be based on sound actuarial principles using historical experience and reasonable assumptions. Reserve levels must be analyzed and updated at least biennially for each major risk being insured and take into account any reinsurance, coinsurance, etc. Reserve levels related to employee-related coverages will normally be limited to the value of claims:
- (A) Submitted and adjudicated but not paid;
- (B) Submitted but not adjudicated; and
- (C) Incurred but not submitted.
- (ii) Reserve levels in excess of the amounts based on the above must be identified and justified in the cost allocation plan or indirect cost rate proposal.
- (4) Accounting records, actuarial studies, and cost allocations (or billings) must recognize any significant differences due to types of insured risk and losses generated by the various insured activities or agencies of the non-Federal entity. If individual departments or agencies of the non-Federal entity experience significantly different levels of claims for a particular risk, those differences are to be recognized by the use of separate allocations or other techniques resulting in an equitable allocation.
- (5) Whenever funds are transferred from a self-insurance reserve to other accounts (e.g., general fund or unrestricted account), refunds must be made to the Federal Government for its share of funds transferred, including earned or imputed interest from the date of transfer and debt interest, if applicable, chargeable in accordance with applicable Federal cognizant agency for indirect cost, claims collection regulations.
- (e) Insurance refunds must be credited against insurance costs in the year the refund is received.
- (f) Indemnification includes securing the non-Federal entity against liabilities to third persons and other losses not compensated by insurance or otherwise. The Federal Government is obligated to indemnify the non-Federal entity only to the extent expressly provided for in the Federal award, except as provided in paragraph (c) of this section.

[↑ Back to Top](#)

§200.448 Intellectual property.

- (a) *Patent costs.* (1) The following costs related to securing patents and copyrights are allowable:
- (i) Costs of preparing disclosures, reports, and other documents required by the Federal award, and of searching the art to the extent necessary to make such disclosures;
- (ii) Costs of preparing documents and any other patent costs in connection with the filing and prosecution of a United States patent application where title or royalty-free license is required by the Federal Government to be conveyed to the Federal Government; and
- (iii) General counseling services relating to patent and copyright matters, such as advice on patent and copyright laws, regulations, clauses, and employee intellectual property agreements (See also §200.459 Professional service costs).
- (2) The following costs related to securing patents and copyrights are unallowable:
- (i) Costs of preparing disclosures, reports, and other documents, and of searching the art to make disclosures not required by the Federal award;

(ii) Costs in connection with filing and prosecuting any foreign patent application, or any United States patent application, where the Federal award does not require conveying title or a royalty-free license to the Federal Government.

(b) *Royalties and other costs for use of patents and copyrights.* (1) Royalties on a patent or copyright or amortization of the cost of acquiring by purchase a copyright, patent, or rights thereto, necessary for the proper performance of the Federal award are allowable unless:

- (i) The Federal Government already has a license or the right to free use of the patent or copyright.
- (ii) The patent or copyright has been adjudicated to be invalid, or has been administratively determined to be invalid.
- (iii) The patent or copyright is considered to be unenforceable.
- (iv) The patent or copyright is expired.

(2) Special care should be exercised in determining reasonableness where the royalties may have been arrived at as a result of less-than-arm's-length bargaining, such as:

- (i) Royalties paid to persons, including corporations, affiliated with the non-Federal entity.
- (ii) Royalties paid to unaffiliated parties, including corporations, under an agreement entered into in contemplation that a Federal award would be made.
- (iii) Royalties paid under an agreement entered into after a Federal award is made to a non-Federal entity.

(3) In any case involving a patent or copyright formerly owned by the non-Federal entity, the amount of royalty allowed must not exceed the cost which would have been allowed had the non-Federal entity retained title thereto.

[78 FR 78608, Dec. 26, 2013, as amended at 79 FR 75886, Dec. 19, 2014]

[↑ Back to Top](#)

§200.449 Interest.

(a) *General.* Costs incurred for interest on borrowed capital, temporary use of endowment funds, or the use of the non-Federal entity's own funds, however represented, are unallowable. Financing costs (including interest) to acquire, construct, or replace capital assets are allowable, subject to the conditions in this section.

(b)(1) Capital assets is defined as noted in §200.12 Capital assets. An asset cost includes (as applicable) acquisition costs, construction costs, and other costs capitalized in accordance with GAAP.

(2) For non-Federal entity fiscal years beginning on or after January 1, 2016, intangible assets include patents and computer software. For software development projects, only interest attributable to the portion of the project costs capitalized in accordance with GAAP is allowable.

(c) *Conditions for all non-Federal entities.* (1) The non-Federal entity uses the capital assets in support of Federal awards;

(2) The allowable asset costs to acquire facilities and equipment are limited to a fair market value available to the non-Federal entity from an unrelated (arm's length) third party.

(3) The non-Federal entity obtains the financing via an arm's-length transaction (that is, a transaction with an unrelated third party); or claims reimbursement of actual interest cost at a rate available via such a transaction.

(4) The non-Federal entity limits claims for Federal reimbursement of interest costs to the least expensive alternative. For example, a capital lease may be determined less costly than purchasing through debt financing, in which case reimbursement must be limited to the amount of interest determined if leasing had been used.

(5) The non-Federal entity expenses or capitalizes allowable interest cost in accordance with GAAP.

(6) Earnings generated by the investment of borrowed funds pending their disbursement for the asset costs are used to offset the current period's allowable interest cost, whether that cost is expensed or capitalized. Earnings subject to being reported to the Federal Internal Revenue Service under arbitrage requirements are excludable.

(7) The following conditions must apply to debt arrangements over \$1 million to purchase or construct facilities, unless the non-Federal entity makes an initial equity contribution to the purchase of 25 percent or more. For this purpose, "initial equity contribution" means the amount or value of contributions made by the non-Federal entity for the acquisition of facilities prior to occupancy.

(i) The non-Federal entity must reduce claims for reimbursement of interest cost by an amount equal to imputed interest earnings on excess cash flow attributable to the portion of the facility used for Federal awards.

(ii) The non-Federal entity must impute interest on excess cash flow as follows:

(A) Annually, the non-Federal entity must prepare a cumulative (from the inception of the project) report of monthly cash inflows and outflows, regardless of the funding source. For this purpose, inflows consist of Federal reimbursement for depreciation, amortization of capitalized construction interest, and annual interest cost. Outflows consist of initial equity contributions, debt principal payments (less the pro-rata share attributable to the cost of land), and interest payments.

(B) To compute monthly cash inflows and outflows, the non-Federal entity must divide the annual amounts determined in step (i) by the number of months in the year (usually 12) that the building is in service.

(C) For any month in which cumulative cash inflows exceed cumulative outflows, interest must be calculated on the excess inflows for that month and be treated as a reduction to allowable interest cost. The rate of interest to be used must be the three-month Treasury bill closing rate as of the last business day of that month.

(8) Interest attributable to a fully depreciated asset is unallowable.

(d) Additional conditions for states, local governments and Indian tribes. For costs to be allowable, the non-Federal entity must have incurred the interest costs for buildings after October 1, 1980, or for land and equipment after September 1, 1995.

(1) The requirement to offset interest earned on borrowed funds against current allowable interest cost (paragraph (c)(5), above) also applies to earnings on debt service reserve funds.

(2) The non-Federal entity will negotiate the amount of allowable interest cost related to the acquisition of facilities with asset costs of \$1 million or more, as outlined in paragraph (c)(7) of this section. For this purpose, a non-Federal entity must consider only cash inflows and outflows attributable to that portion of the real property used for Federal awards.

(e) Additional conditions for IHEs. For costs to be allowable, the IHE must have incurred the interest costs after September 23, 1982, in connection with acquisitions of capital assets that occurred after that date.

(f) Additional condition for nonprofit organizations. For costs to be allowable, the nonprofit organization incurred the interest costs after September 29, 1995, in connection with acquisitions of capital assets that occurred after that date.

(g) The interest allowability provisions of this section do not apply to a nonprofit organization subject to "full coverage" under the Cost Accounting Standards (CAS), as defined at 48 CFR 9903.201-2(a). The non-Federal entity's Federal awards are instead subject to CAS 414 (48 CFR 9904.414), "Cost of Money as an Element of the Cost of Facilities Capital", and CAS 417 (48 CFR 9904.417), "Cost of Money as an Element of the Cost of Capital Assets Under Construction".

[↑ Back to Top](#)

§200.450 Lobbying.

(a) The cost of certain influencing activities associated with obtaining grants, contracts, cooperative agreements, or loans is an unallowable cost. Lobbying with respect to certain grants, contracts, cooperative agreements, and loans is governed by relevant statutes, including among others, the provisions of 31 U.S.C. 1352, as well as the common rule, "New Restrictions on Lobbying" published at 55 FR 6736 (February 26, 1990), including definitions, and the Office of Management and Budget "Governmentwide Guidance for New Restrictions on Lobbying" and notices published at 54 FR 52306 (December 20, 1989), 55 FR 24540 (June 15, 1990), 57 FR 1772 (January 15, 1992), and 61 FR 1412 (January 19, 1996).

(b) Executive lobbying costs. Costs incurred in attempting to improperly influence either directly or indirectly, an employee or officer of the executive branch of the Federal Government to give consideration or to act regarding a Federal award or a regulatory matter are unallowable. Improper influence means any influence that induces or tends to induce a Federal employee or officer to give consideration or to act regarding a Federal award or regulatory matter on any basis other than the merits of the matter.

(c) In addition to the above, the following restrictions are applicable to nonprofit organizations and IHEs:

(1) Costs associated with the following activities are unallowable:

(i) Attempts to influence the outcomes of any Federal, state, or local election, referendum, initiative, or similar procedure, through in-kind or cash contributions, endorsements, publicity, or similar activity;

(ii) Establishing, administering, contributing to, or paying the expenses of a political party, campaign, political action committee, or other organization established for the purpose of influencing the outcomes of elections in the United States;

(iii) Any attempt to influence:

(A) The introduction of Federal or state legislation;

(B) The enactment or modification of any pending Federal or state legislation through communication with any member or employee of the Congress or state legislature (including efforts to influence state or local officials to engage in similar lobbying activity);

(C) The enactment or modification of any pending Federal or state legislation by preparing, distributing, or using publicity or propaganda, or by urging members of the general public, or any segment thereof, to contribute to or participate in any mass demonstration, march, rally, fund raising drive, lobbying campaign or letter writing or telephone campaign; or

(D) Any government official or employee in connection with a decision to sign or veto enrolled legislation;

(iv) Legislative liaison activities, including attendance at legislative sessions or committee hearings, gathering information regarding legislation, and analyzing the effect of legislation, when such activities are carried on in support of or in knowing preparation for an effort to engage in unallowable lobbying.

(2) The following activities are excepted from the coverage of paragraph (c)(1) of this section:

(i) Technical and factual presentations on topics directly related to the performance of a grant, contract, or other agreement (through hearing testimony, statements, or letters to the Congress or a state legislature, or subdivision, member, or cognizant staff member thereof), in response to a documented request (including a Congressional Record notice requesting testimony or statements for the record at a regularly scheduled hearing) made by the non-Federal entity's member of congress, legislative body or a subdivision, or a cognizant staff member thereof, provided such information is readily obtainable and can be readily put in deliverable form, and further provided that costs under this section for travel, lodging or meals are unallowable unless incurred to offer testimony at a regularly scheduled Congressional hearing pursuant to a written request for such presentation made by the Chairman or Ranking Minority Member of the Committee or Subcommittee conducting such hearings;

(ii) Any lobbying made unallowable by paragraph (c)(1)(iii) of this section to influence state legislation in order to directly reduce the cost, or to avoid material impairment of the non-Federal entity's authority to perform the grant, contract, or other agreement; or

(iii) Any activity specifically authorized by statute to be undertaken with funds from the Federal award.

(iv) Any activity excepted from the definitions of "lobbying" or "influencing legislation" by the Internal Revenue Code provisions that require nonprofit organizations to limit their participation in direct and "grass roots" lobbying activities in order to retain their charitable deduction status and avoid punitive excise taxes, I.R.C. §§501(c)(3), 501(h), 4911(a), including:

(A) Nonpartisan analysis, study, or research reports;

(B) Examinations and discussions of broad social, economic, and similar problems; and

(C) Information provided upon request by a legislator for technical advice and assistance, as defined by I.R.C. §4911(d)(2) and 26 CFR 56.4911-2(c)(1)-(c)(3).

(v) When a non-Federal entity seeks reimbursement for indirect (F&A) costs, total lobbying costs must be separately identified in the indirect (F&A) cost rate proposal, and thereafter treated as other unallowable activity costs in accordance with the procedures of §200.413 Direct costs.

(vi) The non-Federal entity must submit as part of its annual indirect (F&A) cost rate proposal a certification that the requirements and standards of this section have been complied with. (See also §200.415 Required certifications.)

(vii)(A) Time logs, calendars, or similar records are not required to be created for purposes of complying with the record keeping requirements in §200.302 Financial management with respect to lobbying costs during any particular calendar month when:

(1) The employee engages in lobbying (as defined in paragraphs (c)(1) and (c)(2) of this section) 25 percent or less of the employee's compensated hours of employment during that calendar month; and

(2) Within the preceding five-year period, the non-Federal entity has not materially misstated allowable or unallowable costs of any nature, including legislative lobbying costs.

(B) When conditions in paragraph (c)(2)(vii)(A)(1) and (2) of this section are met, non-Federal entities are not required to establish records to support the allowability of claimed costs in addition to records already required or maintained. Also, when conditions in paragraphs (c)(2)(vii)(A)(1) and (2) of this section are met, the absence of time logs, calendars, or similar records will not serve as a basis for disallowing costs by contesting estimates of lobbying time spent by employees during a calendar month.

(viii) The Federal awarding agency must establish procedures for resolving in advance, in consultation with OMB, any significant questions or disagreements concerning the interpretation or application of this section. Any such advance resolutions must be binding in any subsequent settlements, audits, or investigations with respect to that grant or contract for purposes of interpretation of this part, provided, however, that this must not be construed to prevent a contractor or non-Federal entity from contesting the lawfulness of such a determination.

[↑ Back to Top](#)

§200.451 Losses on other awards or contracts.

Any excess of costs over income under any other award or contract of any nature is unallowable. This includes, but is not limited to, the non-Federal entity's contributed portion by reason of cost-sharing agreements or any under-recoveries through negotiation of flat amounts for indirect (F&A) costs. Also, any excess of costs over authorized funding levels transferred from any award or contract to another award or contract is unallowable. All losses are not allowable indirect (F&A) costs and are required to be included in the appropriate indirect cost rate base for allocation of indirect costs.

[↑ Back to Top](#)

§200.452 Maintenance and repair costs.

Costs incurred for utilities, insurance, security, necessary maintenance, janitorial services, repair, or upkeep of buildings and equipment (including Federal property unless otherwise provided for) which neither add to the permanent value of the property nor appreciably prolong its intended life, but keep it in an efficient operating condition, are allowable. Costs incurred for improvements which add to the permanent value of the buildings and equipment or appreciably prolong their intended life must be treated as capital expenditures (see §200.439 Equipment and other capital expenditures). These costs are only allowable to the extent not paid through rental or other agreements.

[↑ Back to Top](#)

§200.453 Materials and supplies costs, including costs of computing devices.

(a) Costs incurred for materials, supplies, and fabricated parts necessary to carry out a Federal award are allowable.

(b) Purchased materials and supplies must be charged at their actual prices, net of applicable credits. Withdrawals from general stores or stockrooms must be charged at their actual net cost under any recognized method of pricing inventory withdrawals, consistently applied. Incoming transportation charges are a proper part of materials and supplies costs.

(c) Materials and supplies used for the performance of a Federal award may be charged as direct costs. In the specific case of computing devices, charging as direct costs is allowable for devices that are essential and allocable, but not solely dedicated, to the performance of a Federal award.

(d) Where federally-donated or furnished materials are used in performing the Federal award, such materials will be used without charge.

[78 FR 78608, Dec. 26, 2013, as amended at 79 FR 75887, Dec. 19, 2014]

[↑ Back to Top](#)

§200.454 Memberships, subscriptions, and professional activity costs.

(a) Costs of the non-Federal entity's membership in business, technical, and professional organizations are allowable.

(b) Costs of the non-Federal entity's subscriptions to business, professional, and technical periodicals are allowable.

(c) Costs of membership in any civic or community organization are allowable with prior approval by the Federal awarding agency or pass-through entity.

(d) Costs of membership in any country club or social or dining club or organization are unallowable.

(e) Costs of membership in organizations whose primary purpose is lobbying are unallowable. See also §200.450 Lobbying.

[↑ Back to Top](#)

§200.455 Organization costs.

Costs such as incorporation fees, brokers' fees, fees to promoters, organizers or management consultants, attorneys, accountants, or investment counselor, whether or not employees of the non-Federal entity in connection with establishment or reorganization of an organization, are unallowable except with prior approval of the Federal awarding agency.

[↑ Back to Top](#)

§200.456 Participant support costs.

Participant support costs as defined in §200.75 Participant support costs are allowable with the prior approval of the Federal awarding agency.

[↑ Back to Top](#)

§200.457 Plant and security costs.

Necessary and reasonable expenses incurred for protection and security of facilities, personnel, and work products are allowable. Such costs include, but are not limited to, wages and uniforms of personnel engaged in security activities; equipment; barriers; protective (non-military) gear, devices, and equipment; contractual security services; and consultants. Capital expenditures for plant security purposes are subject to §200.439 Equipment and other capital expenditures.

[78 FR 78608, Dec. 26, 2013, as amended at 79 FR 75887, Dec. 19, 2014]

[↑ Back to Top](#)

§200.458 Pre-award costs.

Pre-award costs are those incurred prior to the effective date of the Federal award directly pursuant to the negotiation and in anticipation of the Federal award where such costs are necessary for efficient and timely performance of the scope of work. Such costs are allowable only to the extent that they would have been allowable if incurred after the date of the Federal award and only with the written approval of the Federal awarding agency.

[↑ Back to Top](#)

§200.459 Professional service costs.

(a) Costs of professional and consultant services rendered by persons who are members of a particular profession or possess a special skill, and who are not officers or employees of the non-Federal entity, are allowable, subject to paragraphs (b) and (c) when reasonable in relation to the services rendered and when not contingent upon recovery of the costs from the Federal Government. In addition, legal and related services are limited under §200.435 Defense and prosecution of criminal and civil proceedings, claims, appeals and patent infringements.

(b) In determining the allowability of costs in a particular case, no single factor or any special combination of factors is necessarily determinative. However, the following factors are relevant:

- (1) The nature and scope of the service rendered in relation to the service required.
- (2) The necessity of contracting for the service, considering the non-Federal entity's capability in the particular area.
- (3) The past pattern of such costs, particularly in the years prior to Federal awards.
- (4) The impact of Federal awards on the non-Federal entity's business (i.e., what new problems have arisen).

(5) Whether the proportion of Federal work to the non-Federal entity's total business is such as to influence the non-Federal entity in favor of incurring the cost, particularly where the services rendered are not of a continuing nature and have little relationship to work under Federal awards.

(6) Whether the service can be performed more economically by direct employment rather than contracting.

(7) The qualifications of the individual or concern rendering the service and the customary fees charged, especially on non-federally funded activities.

(8) Adequacy of the contractual agreement for the service (e.g., description of the service, estimate of time required, rate of compensation, and termination provisions).

(c) In addition to the factors in paragraph (b) of this section, to be allowable, retainer fees must be supported by evidence of bona fide services available or rendered.

[↑ Back to Top](#)

§200.460 Proposal costs.

Proposal costs are the costs of preparing bids, proposals, or applications on potential Federal and non-Federal awards or projects, including the development of data necessary to support the non-Federal entity's bids or proposals. Proposal costs of the current accounting period of both successful and unsuccessful bids and proposals normally should be treated as indirect (F&A) costs and allocated currently to all activities of the non-Federal entity. No proposal costs of past accounting periods will be allocable to the current period.

[↑ Back to Top](#)

§200.461 Publication and printing costs.

(a) Publication costs for electronic and print media, including distribution, promotion, and general handling are allowable. If these costs are not identifiable with a particular cost objective, they should be allocated as indirect costs to all benefiting activities of the non-Federal entity.

(b) Page charges for professional journal publications are allowable where:

(1) The publications report work supported by the Federal Government; and

(2) The charges are levied impartially on all items published by the journal, whether or not under a Federal award.

(3) The non-Federal entity may charge the Federal award before closeout for the costs of publication or sharing of research results if the costs are not incurred during the period of performance of the Federal award.

[↑ Back to Top](#)

§200.462 Rearrangement and reconversion costs.

(a) Costs incurred for ordinary and normal rearrangement and alteration of facilities are allowable as indirect costs. Special arrangements and alterations costs incurred specifically for a Federal award are allowable as a direct cost with the prior approval of the Federal awarding agency or pass-through entity.

(b) Costs incurred in the restoration or rehabilitation of the non-Federal entity's facilities to approximately the same condition existing immediately prior to commencement of Federal awards, less costs related to normal wear and tear, are allowable.

[↑ Back to Top](#)

§200.463 Recruiting costs.

(a) Subject to paragraphs (b) and (c) of this section, and provided that the size of the staff recruited and maintained is in keeping with workload requirements, costs of "help wanted" advertising, operating costs of an employment office necessary to secure and maintain an adequate staff, costs of operating an aptitude and educational testing program, travel costs of employees while engaged in recruiting personnel, travel costs of applicants for interviews for prospective employment, and relocation costs incurred incident to recruitment of new employees, are allowable to the extent that such costs are incurred pursuant to the non-Federal entity's standard recruitment program. Where the non-Federal entity uses employment agencies, costs not in excess of standard commercial rates for such services are allowable.

(b) Special emoluments, fringe benefits, and salary allowances incurred to attract professional personnel that do not meet the test of reasonableness or do not conform with the established practices of the non-Federal entity, are unallowable.

(c) Where relocation costs incurred incident to recruitment of a new employee have been funded in whole or in part to a Federal award, and the newly hired employee resigns for reasons within the employee's control within 12 months after hire, the non-Federal entity will be required to refund or credit the Federal share of such relocation costs to the Federal Government. See also §200.464 Relocation costs of employees.

(d) Short-term, travel visa costs (as opposed to longer-term, immigration visas) are generally allowable expenses that may be proposed as a direct cost. Since short-term visas are issued for a specific period and purpose, they can be clearly identified as directly connected to work performed on a Federal award. For these costs to be directly charged to a Federal award, they must:

(1) Be critical and necessary for the conduct of the project;

(2) Be allowable under the applicable cost principles;

(3) Be consistent with the non-Federal entity's cost accounting practices and non-Federal entity policy; and

(4) Meet the definition of "direct cost" as described in the applicable cost principles.

[78 FR 78608, Dec. 26, 2013, as amended at 79 FR 75887, Dec. 19, 2014]

[↑ Back to Top](#)

§200.464 Relocation costs of employees.

(a) Relocation costs are costs incident to the permanent change of duty assignment (for an indefinite period or for a stated period of not less than 12 months) of an existing employee or upon recruitment of a new employee. Relocation costs are allowable, subject to the limitations described in paragraphs (b), (c), and (d) of this section, provided that:

(1) The move is for the benefit of the employer.

(2) Reimbursement to the employee is in accordance with an established written policy consistently followed by the employer.

(3) The reimbursement does not exceed the employee's actual (or reasonably estimated) expenses.

(b) Allowable relocation costs for current employees are limited to the following:

(1) The costs of transportation of the employee, members of his or her immediate family and his household, and personal effects to the new location.

(2) The costs of finding a new home, such as advance trips by employees and spouses to locate living quarters and temporary lodging during the transition period, up to maximum period of 30 calendar days.

(3) Closing costs, such as brokerage, legal, and appraisal fees, incident to the disposition of the employee's former home. These costs, together with those described in (4), are limited to 8 per cent of the sales price of the employee's former home.

(4) The continuing costs of ownership (for up to six months) of the vacant former home after the settlement or lease date of the employee's new permanent home, such as maintenance of buildings and grounds (exclusive of fixing-up expenses), utilities, taxes, and property insurance.

(5) Other necessary and reasonable expenses normally incident to relocation, such as the costs of canceling an unexpired lease, transportation of personal property, and purchasing insurance against loss of or damages to personal property. The cost of canceling an unexpired lease is limited to three times the monthly rental.

(c) Allowable relocation costs for new employees are limited to those described in paragraphs (b)(1) and (2) of this section. When relocation costs incurred incident to the recruitment of new employees have been charged to a Federal award and the employee resigns for reasons within the employee's control within 12 months after hire, the non-Federal entity must refund or credit the Federal Government for its share of the cost. However, the costs of travel to an overseas location must be considered travel costs in accordance with §200.474 Travel costs, and not this §200.464 Relocation costs of employees, for the purpose of this paragraph if dependents are not permitted at the location for any reason and the costs do not include costs of transporting household goods.

(d) The following costs related to relocation are unallowable:

- (1) Fees and other costs associated with acquiring a new home.
- (2) A loss on the sale of a former home.
- (3) Continuing mortgage principal and interest payments on a home being sold.
- (4) Income taxes paid by an employee related to reimbursed relocation costs.

[78 FR 78608, Dec. 26, 2013, as amended at 79 FR 75887, Dec. 19, 2014]

[↑ Back to Top](#)

§200.465 Rental costs of real property and equipment.

(a) Subject to the limitations described in paragraphs (b) through (d) of this section, rental costs are allowable to the extent that the rates are reasonable in light of such factors as: rental costs of comparable property, if any; market conditions in the area; alternatives available; and the type, life expectancy, condition, and value of the property leased. Rental arrangements should be reviewed periodically to determine if circumstances have changed and other options are available.

(b) Rental costs under "sale and lease back" arrangements are allowable only up to the amount that would be allowed had the non-Federal entity continued to own the property. This amount would include expenses such as depreciation, maintenance, taxes, and insurance.

(c) Rental costs under "less-than-arm's-length" leases are allowable only up to the amount (as explained in paragraph (b) of this section). For this purpose, a less-than-arm's-length lease is one under which one party to the lease agreement is able to control or substantially influence the actions of the other. Such leases include, but are not limited to those between:

- (1) Divisions of the non-Federal entity;
- (2) The non-Federal entity under common control through common officers, directors, or members; and
- (3) The non-Federal entity and a director, trustee, officer, or key employee of the non-Federal entity or an immediate family member, either directly or through corporations, trusts, or similar arrangements in which they hold a controlling interest. For example, the non-Federal entity may establish a separate corporation for the sole purpose of owning property and leasing it back to the non-Federal entity.
- (4) Family members include one party with any of the following relationships to another party:
 - (i) Spouse, and parents thereof;
 - (ii) Children, and spouses thereof;
 - (iii) Parents, and spouses thereof;
 - (iv) Siblings, and spouses thereof;
 - (v) Grandparents and grandchildren, and spouses thereof;
 - (vi) Domestic partner and parents thereof, including domestic partners of any individual in 2 through 5 of this definition; and
 - (vii) Any individual related by blood or affinity whose close association with the employee is the equivalent of a family relationship.
- (5) Rental costs under leases which are required to be treated as capital leases under GAAP are allowable only up to the amount (as explained in paragraph (b) of this section) that would be allowed had the non-Federal entity purchased the property on the date the lease agreement was executed. The provisions of GAAP must be used to determine whether a lease is a capital lease. Interest costs related to capital leases are allowable to the extent they meet the criteria in §200.449 Interest. Unallowable costs include amounts paid for profit, management fees, and taxes that would not have been incurred had the non-Federal entity purchased the property.

(6) The rental of any property owned by any individuals or entities affiliated with the non-Federal entity, to include commercial or residential real estate, for purposes such as the home office workspace is unallowable.

[↑ Back to Top](#)

§200.466 Scholarships and student aid costs.

(a) Costs of scholarships, fellowships, and other programs of student aid at IHEs are allowable only when the purpose of the Federal award is to provide training to selected participants and the charge is approved by the Federal awarding agency. However, tuition remission and other forms of compensation paid as, or in lieu of, wages to students performing necessary work are allowable provided that:

- (1) The individual is conducting activities necessary to the Federal award;
- (2) Tuition remission and other support are provided in accordance with established policy of the IHE and consistently provided in a like manner to students in return for similar activities conducted under Federal awards as well as other activities; and

(3) During the academic period, the student is enrolled in an advanced degree program at a non-Federal entity or affiliated institution and the activities of the student in relation to the Federal award are related to the degree program;

(4) The tuition or other payments are reasonable compensation for the work performed and are conditioned explicitly upon the performance of necessary work; and

(5) It is the IHE's practice to similarly compensate students under Federal awards as well as other activities.

(b) Charges for tuition remission and other forms of compensation paid to students as, or in lieu of, salaries and wages must be subject to the reporting requirements in §200.430 Compensation—personal services, and must be treated as direct or indirect cost in accordance with the actual work being performed. Tuition remission may be charged on an average rate basis. See also §200.431 Compensation—fringe benefits.

[↑ Back to Top](#)

§200.467 Selling and marketing costs.

Costs of selling and marketing any products or services of the non-Federal entity (unless allowed under §200.421 Advertising and public relations.) are unallowable, except as direct costs, with prior approval by the Federal awarding agency when necessary for the performance of the Federal award.

[↑ Back to Top](#)

§200.468 Specialized service facilities.

(a) The costs of services provided by highly complex or specialized facilities operated by the non-Federal entity, such as computing facilities, wind tunnels, and reactors are allowable, provided the charges for the services meet the conditions of either paragraphs (b) or (c) of this section, and, in addition, take into account any items of income or Federal financing that qualify as applicable credits under §200.406 Applicable credits.

(b) The costs of such services, when material, must be charged directly to applicable awards based on actual usage of the services on the basis of a schedule of rates or established methodology that:

(1) Does not discriminate between activities under Federal awards and other activities of the non-Federal entity, including usage by the non-Federal entity for internal purposes, and

(2) Is designed to recover only the aggregate costs of the services. The costs of each service must consist normally of both its direct costs and its allocable share of all indirect (F&A) costs. Rates must be adjusted at least biennially, and must take into consideration over/under applied costs of the previous period(s).

(c) Where the costs incurred for a service are not material, they may be allocated as indirect (F&A) costs.

(d) Under some extraordinary circumstances, where it is in the best interest of the Federal Government and the non-Federal entity to establish alternative costing arrangements, such arrangements may be worked out with the Federal cognizant agency for indirect costs.

[↑ Back to Top](#)

§200.469 Student activity costs.

Costs incurred for intramural activities, student publications, student clubs, and other student activities, are unallowable, unless specifically provided for in the Federal award.

[↑ Back to Top](#)

§200.470 Taxes (including Value Added Tax).

(a) For states, local governments and Indian tribes:

(1) Taxes that a governmental unit is legally required to pay are allowable, except for self-assessed taxes that disproportionately affect Federal programs or changes in tax policies that disproportionately affect Federal programs.

(2) Gasoline taxes, motor vehicle fees, and other taxes that are in effect user fees for benefits provided to the Federal Government are allowable.

(3) This provision does not restrict the authority of the Federal awarding agency to identify taxes where Federal participation is inappropriate. Where the identification of the amount of unallowable taxes would require an inordinate amount of effort, the cognizant agency for indirect costs may accept a reasonable approximation thereof.

(b) For nonprofit organizations and IHEs:

(1) In general, taxes which the non-Federal entity is required to pay and which are paid or accrued in accordance with GAAP, and payments made to local governments in lieu of taxes which are commensurate with the local government services received are allowable, except for:

(i) Taxes from which exemptions are available to the non-Federal entity directly or which are available to the non-Federal entity based on an exemption afforded the Federal Government and, in the latter case, when the Federal awarding agency makes available the necessary exemption certificates,

(ii) Special assessments on land which represent capital improvements, and

(iii) Federal income taxes.

(2) Any refund of taxes, and any payment to the non-Federal entity of interest thereon, which were allowed as Federal award costs, will be credited either as a cost reduction or cash refund, as appropriate, to the Federal Government. However, any interest actually paid or credited to a non-Federal entity incident to a refund of tax, interest, and penalty will be paid or credited to the Federal Government only to the extent that

such interest accrued over the period during which the non-Federal entity has been reimbursed by the Federal Government for the taxes, interest, and penalties.

(c) Value Added Tax (VAT) Foreign taxes charged for the purchase of goods or services that a non-Federal entity is legally required to pay in country is an allowable expense under Federal awards. Foreign tax refunds or applicable credits under Federal awards refer to receipts, or reduction of expenditures, which operate to offset or reduce expense items that are allocable to Federal awards as direct or indirect costs. To the extent that such credits accrued or received by the non-Federal entity relate to allowable cost, these costs must be credited to the Federal awarding agency either as costs or cash refunds. If the costs are credited back to the Federal award, the non-Federal entity may reduce the Federal share of costs by the amount of the foreign tax reimbursement, or where Federal award has not expired, use the foreign government tax refund for approved activities under the Federal award with prior approval of the Federal awarding agency.

[↑ Back to Top](#)

§200.471 Termination costs.

Termination of a Federal award generally gives rise to the incurrence of costs, or the need for special treatment of costs, which would not have arisen had the Federal award not been terminated. Cost principles covering these items are set forth in this section. They are to be used in conjunction with the other provisions of this part in termination situations.

(a) The cost of items reasonably usable on the non-Federal entity's other work must not be allowable unless the non-Federal entity submits evidence that it would not retain such items at cost without sustaining a loss. In deciding whether such items are reasonably usable on other work of the non-Federal entity, the Federal awarding agency should consider the non-Federal entity's plans and orders for current and scheduled activity. Contemporaneous purchases of common items by the non-Federal entity must be regarded as evidence that such items are reasonably usable on the non-Federal entity's other work. Any acceptance of common items as allocable to the terminated portion of the Federal award must be limited to the extent that the quantities of such items on hand, in transit, and on order are in excess of the reasonable quantitative requirements of other work.

(b) If in a particular case, despite all reasonable efforts by the non-Federal entity, certain costs cannot be discontinued immediately after the effective date of termination, such costs are generally allowable within the limitations set forth in this part, except that any such costs continuing after termination due to the negligent or willful failure of the non-Federal entity to discontinue such costs must be unallowable.

(c) Loss of useful value of special tooling, machinery, and equipment is generally allowable if:

(1) Such special tooling, special machinery, or equipment is not reasonably capable of use in the other work of the non-Federal entity,

(2) The interest of the Federal Government is protected by transfer of title or by other means deemed appropriate by the Federal awarding agency (see also §200.313 Equipment, paragraph (d), and

(3) The loss of useful value for any one terminated Federal award is limited to that portion of the acquisition cost which bears the same ratio to the total acquisition cost as the terminated portion of the Federal award bears to the entire terminated Federal award and other Federal awards for which the special tooling, machinery, or equipment was acquired.

(d) Rental costs under unexpired leases are generally allowable where clearly shown to have been reasonably necessary for the performance of the terminated Federal award less the residual value of such leases, if:

(1) The amount of such rental claimed does not exceed the reasonable use value of the property leased for the period of the Federal award and such further period as may be reasonable, and

(2) The non-Federal entity makes all reasonable efforts to terminate, assign, settle, or otherwise reduce the cost of such lease. There also may be included the cost of alterations of such leased property, provided such alterations were necessary for the performance of the Federal award, and of reasonable restoration required by the provisions of the lease.

(e) Settlement expenses including the following are generally allowable:

(1) Accounting, legal, clerical, and similar costs reasonably necessary for:

(i) The preparation and presentation to the Federal awarding agency of settlement claims and supporting data with respect to the terminated portion of the Federal award, unless the termination is for cause (see Subpart D—Post Federal Award Requirements of this part, §§200.338 Remedies for Noncompliance through 200.342 Effects of Suspension and termination); and

(ii) The termination and settlement of subawards.

(2) Reasonable costs for the storage, transportation, protection, and disposition of property provided by the Federal Government or acquired or produced for the Federal award.

(f) Claims under subawards, including the allocable portion of claims which are common to the Federal award and to other work of the non-Federal entity, are generally allowable. An appropriate share of the non-Federal entity's indirect costs may be allocated to the amount of settlements with contractors and/or subrecipients, provided that the amount allocated is otherwise consistent with the basic guidelines contained in §200.414 Indirect (F&A) costs. The indirect costs so allocated must exclude the same and similar costs claimed directly or indirectly as settlement expenses.

[↑ Back to Top](#)

§200.472 Training and education costs.

The cost of training and education provided for employee development is allowable.

[↑ Back to Top](#)

§200.473 Transportation costs.

Costs incurred for freight, express, cartage, postage, and other transportation services relating either to goods purchased, in process, or delivered, are allowable. When such costs can readily be identified with the items involved, they may be charged directly as transportation costs

or added to the cost of such items. Where identification with the materials received cannot readily be made, inbound transportation cost may be charged to the appropriate indirect (F&A) cost accounts if the non-Federal entity follows a consistent, equitable procedure in this respect. Outbound freight, if reimbursable under the terms and conditions of the Federal award, should be treated as a direct cost.

[↑ Back to Top](#)

§200.474 Travel costs.

(a) *General.* Travel costs are the expenses for transportation, lodging, subsistence, and related items incurred by employees who are in travel status on official business of the non-Federal entity. Such costs may be charged on an actual cost basis, on a per diem or mileage basis in lieu of actual costs incurred, or on a combination of the two, provided the method used is applied to an entire trip and not to selected days of the trip, and results in charges consistent with those normally allowed in like circumstances in the non-Federal entity's non-federally-funded activities and in accordance with non-Federal entity's written travel reimbursement policies. Notwithstanding the provisions of §200.444 General costs of government, travel costs of officials covered by that section are allowable with the prior written approval of the Federal awarding agency or pass-through entity when they are specifically related to the Federal award.

(b) *Lodging and subsistence.* Costs incurred by employees and officers for travel, including costs of lodging, other subsistence, and incidental expenses, must be considered reasonable and otherwise allowable only to the extent such costs do not exceed charges normally allowed by the non-Federal entity in its regular operations as the result of the non-Federal entity's written travel policy. In addition, if these costs are charged directly to the Federal award documentation must justify that:

- (1) Participation of the individual is necessary to the Federal award; and
- (2) The costs are reasonable and consistent with non-Federal entity's established travel policy.

(c)(1) Temporary dependent care costs (as dependent is defined in 26 U.S.C. 152) above and beyond regular dependent care that directly results from travel to conferences is allowable provided that:

- (i) The costs are a direct result of the individual's travel for the Federal award;
- (ii) The costs are consistent with the non-Federal entity's documented travel policy for all entity travel; and
- (iii) Are only temporary during the travel period.

(2) Travel costs for dependents are unallowable, except for travel of duration of six months or more with prior approval of the Federal awarding agency. See also §200.432 Conferences.

(d) In the absence of an acceptable, written non-Federal entity policy regarding travel costs, the rates and amounts established under 5 U.S.C. 5701-11, ("Travel and Subsistence Expenses; Mileage Allowances"), or by the Administrator of General Services, or by the President (or his or her designee) pursuant to any provisions of such subchapter must apply to travel under Federal awards (48 CFR 31.205-46(a)).

(e) *Commercial air travel.* (1) Airfare costs in excess of the basic least expensive unrestricted accommodations class offered by commercial airlines are unallowable except when such accommodations would:

- (i) Require circuitous routing;
- (ii) Require travel during unreasonable hours;
- (iii) Excessively prolong travel;
- (iv) Result in additional costs that would offset the transportation savings; or

(v) Offer accommodations not reasonably adequate for the traveler's medical needs. The non-Federal entity must justify and document these conditions on a case-by-case basis in order for the use of first-class or business-class airfare to be allowable in such cases.

(2) Unless a pattern of avoidance is detected, the Federal Government will generally not question a non-Federal entity's determinations that customary standard airfare or other discount airfare is unavailable for specific trips if the non-Federal entity can demonstrate that such airfare was not available in the specific case.

(f) *Air travel by other than commercial carrier.* Costs of travel by non-Federal entity-owned, -leased, or -chartered aircraft include the cost of lease, charter, operation (including personnel costs), maintenance, depreciation, insurance, and other related costs. The portion of such costs that exceeds the cost of airfare as provided for in paragraph (d) of this section, is unallowable.

[78 FR 78608, Dec. 26, 2013, as amended at 79 FR 75887, Dec. 19, 2014]

[↑ Back to Top](#)

§200.475 Trustees.

Travel and subsistence costs of trustees (or directors) at IHEs and nonprofit organizations are allowable. See also §200.474 Travel costs.

[↑ Back to Top](#)

Subpart F—Audit Requirements

[↑ Back to Top](#)

GENERAL

[↑ Back to Top](#)

§200.500 Purpose.

This part sets forth standards for obtaining consistency and uniformity among Federal agencies for the audit of non-Federal entities expending Federal awards.

[↑ Back to Top](#)

AUDITS

[↑ Back to Top](#)

§200.501 Audit requirements.

(a) *Audit required.* A non-Federal entity that expends \$750,000 or more during the non-Federal entity's fiscal year in Federal awards must have a single or program-specific audit conducted for that year in accordance with the provisions of this part.

(b) *Single audit.* A non-Federal entity that expends \$750,000 or more during the non-Federal entity's fiscal year in Federal awards must have a single audit conducted in accordance with §200.514 Scope of audit except when it elects to have a program-specific audit conducted in accordance with paragraph (c) of this section.

(c) *Program-specific audit election.* When an auditee expends Federal awards under only one Federal program (excluding R&D) and the Federal program's statutes, regulations, or the terms and conditions of the Federal award do not require a financial statement audit of the auditee, the auditee may elect to have a program-specific audit conducted in accordance with §200.507 Program-specific audits. A program-specific audit may not be elected for R&D unless all of the Federal awards expended were received from the same Federal agency, or the same Federal agency and the same pass-through entity, and that Federal agency, or pass-through entity in the case of a subrecipient, approves in advance a program-specific audit.

(d) *Exemption when Federal awards expended are less than \$750,000.* A non-Federal entity that expends less than \$750,000 during the non-Federal entity's fiscal year in Federal awards is exempt from Federal audit requirements for that year, except as noted in §200.503 Relation to other audit requirements, but records must be available for review or audit by appropriate officials of the Federal agency, pass-through entity, and Government Accountability Office (GAO).

(e) *Federally Funded Research and Development Centers (FFRDC).* Management of an auditee that owns or operates a FFRDC may elect to treat the FFRDC as a separate entity for purposes of this part.

(f) *Subrecipients and Contractors.* An auditee may simultaneously be a recipient, a subrecipient, and a contractor. Federal awards expended as a recipient or a subrecipient are subject to audit under this part. The payments received for goods or services provided as a contractor are not Federal awards. Section §200.330 Subrecipient and contractor determinations sets forth the considerations in determining whether payments constitute a Federal award or a payment for goods or services provided as a contractor.

(g) *Compliance responsibility for contractors.* In most cases, the auditee's compliance responsibility for contractors is only to ensure that the procurement, receipt, and payment for goods and services comply with Federal statutes, regulations, and the terms and conditions of Federal awards. Federal award compliance requirements normally do not pass through to contractors. However, the auditee is responsible for ensuring compliance for procurement transactions which are structured such that the contractor is responsible for program compliance or the contractor's records must be reviewed to determine program compliance. Also, when these procurement transactions relate to a major program, the scope of the audit must include determining whether these transactions are in compliance with Federal statutes, regulations, and the terms and conditions of Federal awards.

(h) *For-profit subrecipient.* Since this part does not apply to for-profit subrecipients, the pass-through entity is responsible for establishing requirements, as necessary, to ensure compliance by for-profit subrecipients. The agreement with the for-profit subrecipient must describe applicable compliance requirements and the for-profit subrecipient's compliance responsibility. Methods to ensure compliance for Federal awards made to for-profit subrecipients may include pre-award audits, monitoring during the agreement, and post-award audits. See also §200.331 Requirements for pass-through entities.

[78 FR 78608, Dec. 26, 2013, as amended at 79 FR 75887, Dec. 19, 2014]

[↑ Back to Top](#)

§200.502 Basis for determining Federal awards expended.

(a) *Determining Federal awards expended.* The determination of when a Federal award is expended must be based on when the activity related to the Federal award occurs. Generally, the activity pertains to events that require the non-Federal entity to comply with Federal statutes, regulations, and the terms and conditions of Federal awards, such as: expenditure/expense transactions associated with awards including grants, cost-reimbursement contracts under the FAR, compacts with Indian Tribes, cooperative agreements, and direct appropriations; the disbursement of funds to subrecipients; the use of loan proceeds under loan and loan guarantee programs; the receipt of property; the receipt of surplus property; the receipt or use of program income; the distribution or use of food commodities; the disbursement of amounts entitling the non-Federal entity to an interest subsidy; and the period when insurance is in force.

(b) *Loan and loan guarantees (loans).* Since the Federal Government is at risk for loans until the debt is repaid, the following guidelines must be used to calculate the value of Federal awards expended under loan programs, except as noted in paragraphs (c) and (d) of this section:

- (1) Value of new loans made or received during the audit period; plus
- (2) Beginning of the audit period balance of loans from previous years for which the Federal Government imposes continuing compliance requirements; plus
- (3) Any interest subsidy, cash, or administrative cost allowance received.

(c) *Loan and loan guarantees (loans) at IHEs.* When loans are made to students of an IHE but the IHE does not make the loans, then only the value of loans made during the audit period must be considered Federal awards expended in that audit period. The balance of loans for previous audit periods is not included as Federal awards expended because the lender accounts for the prior balances.

(d) *Prior loan and loan guarantees (loans).* Loans, the proceeds of which were received and expended in prior years, are not considered Federal awards expended under this part when the Federal statutes, regulations, and the terms and conditions of Federal awards pertaining to such loans impose no continuing compliance requirements other than to repay the loans.

(e) *Endowment funds.* The cumulative balance of Federal awards for endowment funds that are federally restricted are considered Federal awards expended in each audit period in which the funds are still restricted.

(f) *Free rent.* Free rent received by itself is not considered a Federal award expended under this part. However, free rent received as part of a Federal award to carry out a Federal program must be included in determining Federal awards expended and subject to audit under this part.

(g) *Valuing non-cash assistance.* Federal non-cash assistance, such as free rent, food commodities, donated property, or donated surplus property, must be valued at fair market value at the time of receipt or the assessed value provided by the Federal agency.

(h) *Medicare.* Medicare payments to a non-Federal entity for providing patient care services to Medicare-eligible individuals are not considered Federal awards expended under this part.

(i) *Medicaid.* Medicaid payments to a subrecipient for providing patient care services to Medicaid-eligible individuals are not considered Federal awards expended under this part unless a state requires the funds to be treated as Federal awards expended because reimbursement is on a cost-reimbursement basis.

(j) *Certain loans provided by the National Credit Union Administration.* For purposes of this part, loans made from the National Credit Union Share Insurance Fund and the Central Liquidity Facility that are funded by contributions from insured non-Federal entities are not considered Federal awards expended.

[78 FR 78608, Dec. 26, 2013, as amended at 79 FR 75887, Dec. 19, 2014]

[↑ Back to Top](#)

§200.503 Relation to other audit requirements.

(a) An audit conducted in accordance with this part must be in lieu of any financial audit of Federal awards which a non-Federal entity is required to undergo under any other Federal statute or regulation. To the extent that such audit provides a Federal agency with the information it requires to carry out its responsibilities under Federal statute or regulation, a Federal agency must rely upon and use that information.

(b) Notwithstanding subsection (a), a Federal agency, Inspector General, or GAO may conduct or arrange for additional audits which are necessary to carry out its responsibilities under Federal statute or regulation. The provisions of this part do not authorize any non-Federal entity to constrain, in any manner, such Federal agency from carrying out or arranging for such additional audits, except that the Federal agency must plan such audits to not be duplicative of other audits of Federal awards. Prior to commencing such an audit, the Federal agency or pass-through entity must review the FAC for recent audits submitted by the non-Federal entity, and to the extent such audits meet a Federal agency or pass-through entity's needs, the Federal agency or pass-through entity must rely upon and use such audits. Any additional audits must be planned and performed in such a way as to build upon work performed, including the audit documentation, sampling, and testing already performed, by other auditors.

(c) The provisions of this part do not limit the authority of Federal agencies to conduct, or arrange for the conduct of, audits and evaluations of Federal awards, nor limit the authority of any Federal agency Inspector General or other Federal official. For example, requirements that may be applicable under the FAR or CAS and the terms and conditions of a cost-reimbursement contract may include additional applicable audits to be conducted or arranged for by Federal agencies.

(d) Federal agency to pay for additional audits. A Federal agency that conducts or arranges for additional audits must, consistent with other applicable Federal statutes and regulations, arrange for funding the full cost of such additional audits.

(e) Request for a program to be audited as a major program. A Federal awarding agency may request that an auditee have a particular Federal program audited as a major program in lieu of the Federal awarding agency conducting or arranging for the additional audits. To allow for planning, such requests should be made at least 180 calendar days prior to the end of the fiscal year to be audited. The auditee, after consultation with its auditor, should promptly respond to such a request by informing the Federal awarding agency whether the program would otherwise be audited as a major program using the risk-based audit approach described in §200.518 Major program determination and, if not, the estimated incremental cost. The Federal awarding agency must then promptly confirm to the auditee whether it wants the program audited as a major program. If the program is to be audited as a major program based upon this Federal awarding agency request, and the Federal awarding agency agrees to pay the full incremental costs, then the auditee must have the program audited as a major program. A pass-through entity may use the provisions of this paragraph for a subrecipient.

[↑ Back to Top](#)

§200.504 Frequency of audits.

Except for the provisions for biennial audits provided in paragraphs (a) and (b) of this section, audits required by this part must be performed annually. Any biennial audit must cover both years within the biennial period.

(a) A state, local government, or Indian tribe that is required by constitution or statute, in effect on January 1, 1987, to undergo its audits less frequently than annually, is permitted to undergo its audits pursuant to this part biennially. This requirement must still be in effect for the biennial period.

(b) Any nonprofit organization that had biennial audits for all biennial periods ending between July 1, 1992, and January 1, 1995, is permitted to undergo its audits pursuant to this part biennially.

[↑ Back to Top](#)

§200.505 Sanctions.

In cases of continued inability or unwillingness to have an audit conducted in accordance with this part, Federal agencies and pass-through entities must take appropriate action as provided in §200.338 Remedies for noncompliance.

[↑ Back to Top](#)

§200.506 Audit costs.

See §200.425 Audit services.

[↑ Back to Top](#)

§200.507 Program-specific audits.

(a) *Program-specific audit guide available.* In many cases, a program-specific audit guide will be available to provide specific guidance to the auditor with respect to internal controls, compliance requirements, suggested audit procedures, and audit reporting requirements. A listing of current program-specific audit guides can be found in the compliance supplement beginning with the 2014 supplement including Federal awarding agency contact information and a Web site where a copy of the guide can be obtained. When a current program-specific audit guide is available, the auditor must follow GAGAS and the guide when performing a program-specific audit.

(b) *Program-specific audit guide not available.* (1) When a current program-specific audit guide is not available, the auditee and auditor must have basically the same responsibilities for the Federal program as they would have for an audit of a major program in a single audit.

(2) The auditee must prepare the financial statement(s) for the Federal program that includes, at a minimum, a schedule of expenditures of Federal awards for the program and notes that describe the significant accounting policies used in preparing the schedule, a summary schedule of prior audit findings consistent with the requirements of §200.511 Audit findings follow-up, paragraph (b), and a corrective action plan consistent with the requirements of §200.511 Audit findings follow-up, paragraph (c).

(3) The auditor must:

(i) Perform an audit of the financial statement(s) for the Federal program in accordance with GAGAS;

(ii) Obtain an understanding of internal controls and perform tests of internal controls over the Federal program consistent with the requirements of §200.514 Scope of audit, paragraph (c) for a major program;

(iii) Perform procedures to determine whether the auditee has complied with Federal statutes, regulations, and the terms and conditions of Federal awards that could have a direct and material effect on the Federal program consistent with the requirements of §200.514 Scope of audit, paragraph (d) for a major program;

(iv) Follow up on prior audit findings, perform procedures to assess the reasonableness of the summary schedule of prior audit findings prepared by the auditee in accordance with the requirements of §200.511 Audit findings follow-up, and report, as a current year audit finding, when the auditor concludes that the summary schedule of prior audit findings materially misrepresents the status of any prior audit finding; and

(v) Report any audit findings consistent with the requirements of §200.516 Audit findings.

(4) The auditor's report(s) may be in the form of either combined or separate reports and may be organized differently from the manner presented in this section. The auditor's report(s) must state that the audit was conducted in accordance with this part and include the following:

(i) An opinion (or disclaimer of opinion) as to whether the financial statement(s) of the Federal program is presented fairly in all material respects in accordance with the stated accounting policies;

(ii) A report on internal control related to the Federal program, which must describe the scope of testing of internal control and the results of the tests;

(iii) A report on compliance which includes an opinion (or disclaimer of opinion) as to whether the auditee complied with laws, regulations, and the terms and conditions of Federal awards which could have a direct and material effect on the Federal program; and

(iv) A schedule of findings and questioned costs for the Federal program that includes a summary of the auditor's results relative to the Federal program in a format consistent with §200.515 Audit reporting, paragraph (d)(1) and findings and questioned costs consistent with the requirements of §200.515 Audit reporting, paragraph (d)(3).

(c) *Report submission for program-specific audits.* (1) The audit must be completed and the reporting required by paragraph (c)(2) or (c)(3) of this section submitted within the earlier of 30 calendar days after receipt of the auditor's report(s), or nine months after the end of the audit period, unless a different period is specified in a program-specific audit guide. Unless restricted by Federal law or regulation, the auditee must make report copies available for public inspection. Auditees and auditors must ensure that their respective parts of the reporting package do not include protected personally identifiable information.

(2) When a program-specific audit guide is available, the auditee must electronically submit to the FAC the data collection form prepared in accordance with §200.512 Report submission, paragraph (b), as applicable to a program-specific audit, and the reporting required by the program-specific audit guide.

(3) When a program-specific audit guide is not available, the reporting package for a program-specific audit must consist of the financial statement(s) of the Federal program, a summary schedule of prior audit findings, and a corrective action plan as described in paragraph (b)(2) of this section, and the auditor's report(s) described in paragraph (b)(4) of this section. The data collection form prepared in accordance with §200.512 Report submission, paragraph (b), as applicable to a program-specific audit, and one copy of this reporting package must be electronically submitted to the FAC.

(d) *Other sections of this part may apply.* Program-specific audits are subject to:

(1) 200.500 Purpose through 200.503 Relation to other audit requirements, paragraph (d);

(2) 200.504 Frequency of audits through 200.506 Audit costs;

(3) 200.508 Auditee responsibilities through 200.509 Auditor selection;

(4) 200.511 Audit findings follow-up;

(5) 200.512 Report submission, paragraphs (e) through (h);

(6) 200.513 Responsibilities;

(7) 200.516 Audit findings through 200.517 Audit documentation;

(8) 200.521 Management decision, and

(9) Other referenced provisions of this part unless contrary to the provisions of this section, a program-specific audit guide, or program statutes and regulations.

[78 FR 78608, Dec. 26, 2013, as amended at 79 FR 75887, Dec. 19, 2014]

[↑ Back to Top](#)

AUDITEES

[↑ Back to Top](#)

§200.508 Auditee responsibilities.

The auditee must:

(a) Procure or otherwise arrange for the audit required by this part in accordance with §200.509 Auditor selection, and ensure it is properly performed and submitted when due in accordance with §200.512 Report submission.

(b) Prepare appropriate financial statements, including the schedule of expenditures of Federal awards in accordance with §200.510 Financial statements.

(c) Promptly follow up and take corrective action on audit findings, including preparation of a summary schedule of prior audit findings and a corrective action plan in accordance with §200.511 Audit findings follow-up, paragraph (b) and §200.511 Audit findings follow-up, paragraph (c), respectively.

(d) Provide the auditor with access to personnel, accounts, books, records, supporting documentation, and other information as needed for the auditor to perform the audit required by this part.

[↑ Back to Top](#)

§200.509 Auditor selection.

(a) *Auditor procurement.* In procuring audit services, the auditee must follow the procurement standards prescribed by the Procurement Standards in §§200.317 Procurement by states through 20.326 Contract provisions of Subpart D- Post Federal Award Requirements of this part or the FAR (48 CFR part 42), as applicable. When procuring audit services, the objective is to obtain high-quality audits. In requesting proposals for audit services, the objectives and scope of the audit must be made clear and the non-Federal entity must request a copy of the audit organization's peer review report which the auditor is required to provide under GAGAS. Factors to be considered in evaluating each proposal for audit services include the responsiveness to the request for proposal, relevant experience, availability of staff with professional qualifications and technical abilities, the results of peer and external quality control reviews, and price. Whenever possible, the auditee must make positive efforts to utilize small businesses, minority-owned firms, and women's business enterprises, in procuring audit services as stated in §200.321 Contracting with small and minority businesses, women's business enterprises, and labor surplus area firms, or the FAR (48 CFR part 42), as applicable.

(b) *Restriction on auditor preparing indirect cost proposals.* An auditor who prepares the indirect cost proposal or cost allocation plan may not also be selected to perform the audit required by this part when the indirect costs recovered by the auditee during the prior year exceeded \$1 million. This restriction applies to the base year used in the preparation of the indirect cost proposal or cost allocation plan and any subsequent years in which the resulting indirect cost agreement or cost allocation plan is used to recover costs.

(c) *Use of Federal auditors.* Federal auditors may perform all or part of the work required under this part if they comply fully with the requirements of this part.

[↑ Back to Top](#)

§200.510 Financial statements.

(a) *Financial statements.* The auditee must prepare financial statements that reflect its financial position, results of operations or changes in net assets, and, where appropriate, cash flows for the fiscal year audited. The financial statements must be for the same organizational unit and fiscal year that is chosen to meet the requirements of this part. However, non-Federal entity-wide financial statements may also include departments, agencies, and other organizational units that have separate audits in accordance with §200.514 Scope of audit, paragraph (a) and prepare separate financial statements.

(b) *Schedule of expenditures of Federal awards.* The auditee must also prepare a schedule of expenditures of Federal awards for the period covered by the auditee's financial statements which must include the total Federal awards expended as determined in accordance with §200.502 Basis for determining Federal awards expended. While not required, the auditee may choose to provide information requested by Federal awarding agencies and pass-through entities to make the schedule easier to use. For example, when a Federal program has multiple Federal award years, the auditee may list the amount of Federal awards expended for each Federal award year separately. At a minimum, the schedule must:

(1) List individual Federal programs by Federal agency. For a cluster of programs, provide the cluster name, list individual Federal programs within the cluster of programs, and provide the applicable Federal agency name. For R&D, total Federal awards expended must be shown either by individual Federal award or by Federal agency and major subdivision within the Federal agency. For example, the National Institutes of Health is a major subdivision in the Department of Health and Human Services.

(2) For Federal awards received as a subrecipient, the name of the pass-through entity and identifying number assigned by the pass-through entity must be included.

(3) Provide total Federal awards expended for each individual Federal program and the CFDA number or other identifying number when the CFDA information is not available. For a cluster of programs also provide the total for the cluster.

(4) Include the total amount provided to subrecipients from each Federal program.

(5) For loan or loan guarantee programs described in §200.502 Basis for determining Federal awards expended, paragraph (b), identify in the notes to the schedule the balances outstanding at the end of the audit period. This is in addition to including the total Federal awards expended for loan or loan guarantee programs in the schedule.

(6) Include notes that describe that significant accounting policies used in preparing the schedule, and note whether or not the auditee elected to use the 10% de minimis cost rate as covered in §200.414 Indirect (F&A) costs.

[78 FR 78608, Dec. 26, 2013, as amended at 79 FR 75887, Dec. 19, 2014]

[↑ Back to Top](#)

§200.511 Audit findings follow-up.

(a) *General.* The auditee is responsible for follow-up and corrective action on all audit findings. As part of this responsibility, the auditee must prepare a summary schedule of prior audit findings. The auditee must also prepare a corrective action plan for current year audit findings. The summary schedule of prior audit findings and the corrective action plan must include the reference numbers the auditor assigns to audit findings under §200.516 Audit findings, paragraph (c). Since the summary schedule may include audit findings from multiple years, it must include the fiscal year in which the finding initially occurred. The corrective action plan and summary schedule of prior audit findings must include findings relating to the financial statements which are required to be reported in accordance with GAGAS.

(b) *Summary schedule of prior audit findings.* The summary schedule of prior audit findings must report the status of all audit findings included in the prior audit's schedule of findings and questioned costs. The summary schedule must also include audit findings reported in the prior audit's summary schedule of prior audit findings except audit findings listed as corrected in accordance with paragraph (b)(1) of this section, or no longer valid or not warranting further action in accordance with paragraph (b)(3) of this section.

(1) When audit findings were fully corrected, the summary schedule need only list the audit findings and state that corrective action was taken.

(2) When audit findings were not corrected or were only partially corrected, the summary schedule must describe the reasons for the finding's recurrence and planned corrective action, and any partial corrective action taken. When corrective action taken is significantly different from corrective action previously reported in a corrective action plan or in the Federal agency's or pass-through entity's management decision, the summary schedule must provide an explanation.

(3) When the auditee believes the audit findings are no longer valid or do not warrant further action, the reasons for this position must be described in the summary schedule. A valid reason for considering an audit finding as not warranting further action is that all of the following have occurred:

- (i) Two years have passed since the audit report in which the finding occurred was submitted to the FAC;
- (ii) The Federal agency or pass-through entity is not currently following up with the auditee on the audit finding; and
- (iii) A management decision was not issued.

(c) *Corrective action plan.* At the completion of the audit, the auditee must prepare, in a document separate from the auditor's findings described in §200.516 Audit findings, a corrective action plan to address each audit finding included in the current year auditor's reports. The corrective action plan must provide the name(s) of the contact person(s) responsible for corrective action, the corrective action planned, and the anticipated completion date. If the auditee does not agree with the audit findings or believes corrective action is not required, then the corrective action plan must include an explanation and specific reasons.

[↑ Back to Top](#)

§200.512 Report submission.

(a) *General.* (1) The audit must be completed and the data collection form described in paragraph (b) of this section and reporting package described in paragraph (c) of this section must be submitted within the earlier of 30 calendar days after receipt of the auditor's report(s), or nine months after the end of the audit period. If the due date falls on a Saturday, Sunday, or Federal holiday, the reporting package is due the next business day.

(2) Unless restricted by Federal statutes or regulations, the auditee must make copies available for public inspection. Auditees and auditors must ensure that their respective parts of the reporting package do not include protected personally identifiable information.

(b) *Data Collection.* The FAC is the repository of record for Subpart F—Audit Requirements of this part reporting packages and the data collection form. All Federal agencies, pass-through entities and others interested in a reporting package and data collection form must obtain it by accessing the FAC.

(1) The auditee must submit required data elements described in Appendix X to Part 200—Data Collection Form (Form SF-SAC), which state whether the audit was completed in accordance with this part and provides information about the auditee, its Federal programs, and the results of the audit. The data must include information available from the audit required by this part that is necessary for Federal agencies to use the audit to ensure integrity for Federal programs. The data elements and format must be approved by OMB, available from the FAC, and include collections of information from the reporting package described in paragraph (c) of this section. A senior level representative of the auditee (e.g., state controller, director of finance, chief executive officer, or chief financial officer) must sign a statement to be included as part of the data collection that says that the auditee complied with the requirements of this part, the data were prepared in accordance with this part (and the instructions accompanying the form), the reporting package does not include protected personally identifiable information, the information included in its entirety is accurate and complete, and that the FAC is authorized to make the reporting package and the form publicly available on a Web site.

(2) *Exception for Indian Tribes and Tribal Organizations.* An auditee that is an Indian tribe or a tribal organization (as defined in the Indian Self-Determination, Education and Assistance Act (ISDEAA), 25 U.S.C. 450b(l)) may opt not to authorize the FAC to make the reporting package publicly available on a Web site, by excluding the authorization for the FAC publication in the statement described in paragraph (b)(1) of this section. If this option is exercised, the auditee becomes responsible for submitting the reporting package directly to any pass-through entities through which it has received a Federal award and to pass-through entities for which the summary schedule of prior audit findings reported the

status of any findings related to Federal awards that the pass-through entity provided. Unless restricted by Federal statute or regulation, if the auditee opts not to authorize publication, it must make copies of the reporting package available for public inspection.

(3) Using the information included in the reporting package described in paragraph (c) of this section, the auditor must complete the applicable data elements of the data collection form. The auditor must sign a statement to be included as part of the data collection form that indicates, at a minimum, the source of the information included in the form, the auditor's responsibility for the information, that the form is not a substitute for the reporting package described in paragraph (c) of this section, and that the content of the form is limited to the collection of information prescribed by OMB.

(c) *Reporting package.* The reporting package must include the:

(1) Financial statements and schedule of expenditures of Federal awards discussed in §200.510 Financial statements, paragraphs (a) and (b), respectively;

(2) Summary schedule of prior audit findings discussed in §200.511 Audit findings follow-up, paragraph (b);

(3) Auditor's report(s) discussed in §200.515 Audit reporting; and

(4) Corrective action plan discussed in §200.511 Audit findings follow-up, paragraph (c).

(d) *Submission to FAC.* The auditee must electronically submit to the FAC the data collection form described in paragraph (b) of this section and the reporting package described in paragraph (c) of this section.

(e) *Requests for management letters issued by the auditor.* In response to requests by a Federal agency or pass-through entity, auditees must submit a copy of any management letters issued by the auditor.

(f) *Report retention requirements.* Auditees must keep one copy of the data collection form described in paragraph (b) of this section and one copy of the reporting package described in paragraph (c) of this section on file for three years from the date of submission to the FAC.

(g) *FAC responsibilities.* The FAC must make available the reporting packages received in accordance with paragraph (c) of this section and §200.507 Program-specific audits, paragraph (c) to the public, except for Indian tribes exercising the option in (b)(2) of this section, and maintain a data base of completed audits, provide appropriate information to Federal agencies, and follow up with known auditees that have not submitted the required data collection forms and reporting packages.

(h) *Electronic filing.* Nothing in this part must preclude electronic submissions to the FAC in such manner as may be approved by OMB.

[78 FR 78608, Dec. 26, 2013, as amended at 79 FR 75887, Dec. 19, 2014]

[↑ Back to Top](#)

FEDERAL AGENCIES

[↑ Back to Top](#)

§200.513 Responsibilities.

(a)(1) Cognizant agency for audit responsibilities. A non-Federal entity expending more than \$50 million a year in Federal awards must have a cognizant agency for audit. The designated cognizant agency for audit must be the Federal awarding agency that provides the predominant amount of direct funding to a non-Federal entity unless OMB designates a specific cognizant agency for audit.

(2) To provide for continuity of cognizance, the determination of the predominant amount of direct funding must be based upon direct Federal awards expended in the non-Federal entity's fiscal years ending in 2009, 2014, 2019 and every fifth year thereafter. For example, audit cognizance for periods ending in 2011 through 2015 will be determined based on Federal awards expended in 2009.

(3) Notwithstanding the manner in which audit cognizance is determined, a Federal awarding agency with cognizance for an auditee may reassign cognizance to another Federal awarding agency that provides substantial funding and agrees to be the cognizant agency for audit. Within 30 calendar days after any reassignment, both the old and the new cognizant agency for audit must provide notice of the change to the FAC, the auditee, and, if known, the auditor. The cognizant agency for audit must:

(i) Provide technical audit advice and liaison assistance to auditees and auditors.

(ii) Obtain or conduct quality control reviews on selected audits made by non-Federal auditors, and provide the results to other interested organizations. Cooperate and provide support to the Federal agency designated by OMB to lead a governmentwide project to determine the quality of single audits by providing a statistically reliable estimate of the extent that single audits conform to applicable requirements, standards, and procedures; and to make recommendations to address noted audit quality issues, including recommendations for any changes to applicable requirements, standards and procedures indicated by the results of the project. This governmentwide audit quality project must be performed once every 6 years beginning in 2018 or at such other interval as determined by OMB, and the results must be public.

(iii) Promptly inform other affected Federal agencies and appropriate Federal law enforcement officials of any direct reporting by the auditee or its auditor required by GAGAS or statutes and regulations.

(iv) Advise the community of independent auditors of any noteworthy or important factual trends related to the quality of audits stemming from quality control reviews. Significant problems or quality issues consistently identified through quality control reviews of audit reports must be referred to appropriate state licensing agencies and professional bodies.

(v) Advise the auditor, Federal awarding agencies, and, where appropriate, the auditee of any deficiencies found in the audits when the deficiencies require corrective action by the auditor. When advised of deficiencies, the auditee must work with the auditor to take corrective action. If corrective action is not taken, the cognizant agency for audit must notify the auditor, the auditee, and applicable Federal awarding agencies and pass-through entities of the facts and make recommendations for follow-up action. Major inadequacies or repetitive substandard performance by auditors must be referred to appropriate state licensing agencies and professional bodies for disciplinary action.

(vi) Coordinate, to the extent practical, audits or reviews made by or for Federal agencies that are in addition to the audits made pursuant to this part, so that the additional audits or reviews build upon rather than duplicate audits performed in accordance with this part.

(vii) Coordinate a management decision for cross-cutting audit findings (as defined in §200.30 Cross-cutting audit finding) that affect the Federal programs of more than one agency when requested by any Federal awarding agency whose awards are included in the audit finding of the auditee.

(viii) Coordinate the audit work and reporting responsibilities among auditors to achieve the most cost-effective audit.

(ix) Provide advice to auditees as to how to handle changes in fiscal years.

(b) Oversight agency for audit responsibilities. An auditee who does not have a designated cognizant agency for audit will be under the general oversight of the Federal agency determined in accordance with §200.73 Oversight agency for audit. A Federal agency with oversight for an auditee may reassign oversight to another Federal agency that agrees to be the oversight agency for audit. Within 30 calendar days after any reassignment, both the old and the new oversight agency for audit must provide notice of the change to the FAC, the auditee, and, if known, the auditor. The oversight agency for audit:

(1) Must provide technical advice to auditees and auditors as requested.

(2) May assume all or some of the responsibilities normally performed by a cognizant agency for audit.

(c) Federal awarding agency responsibilities. The Federal awarding agency must perform the following for the Federal awards it makes (See also the requirements of §200.210 Information contained in a Federal award):

(1) Ensure that audits are completed and reports are received in a timely manner and in accordance with the requirements of this part.

(2) Provide technical advice and counsel to auditees and auditors as requested.

(3) Follow-up on audit findings to ensure that the recipient takes appropriate and timely corrective action. As part of audit follow-up, the Federal awarding agency must:

(i) Issue a management decision as prescribed in §200.521 Management decision;

(ii) Monitor the recipient taking appropriate and timely corrective action;

(iii) Use cooperative audit resolution mechanisms (see §200.25 Cooperative audit resolution) to improve Federal program outcomes through better audit resolution, follow-up, and corrective action; and

(iv) Develop a baseline, metrics, and targets to track, over time, the effectiveness of the Federal agency's process to follow-up on audit findings and on the effectiveness of Single Audits in improving non-Federal entity accountability and their use by Federal awarding agencies in making award decisions.

(4) Provide OMB annual updates to the compliance supplement and work with OMB to ensure that the compliance supplement focuses the auditor to test the compliance requirements most likely to cause improper payments, fraud, waste, abuse or generate audit finding for which the Federal awarding agency will take sanctions.

(5) Provide OMB with the name of a single audit accountable official from among the senior policy officials of the Federal awarding agency who must be:

(i) Responsible for ensuring that the agency fulfills all the requirements of paragraph (c) of this section and effectively uses the single audit process to reduce improper payments and improve Federal program outcomes.

(ii) Held accountable to improve the effectiveness of the single audit process based upon metrics as described in paragraph (c)(3)(iv) of this section.

(iii) Responsible for designating the Federal agency's key management single audit liaison.

(6) Provide OMB with the name of a key management single audit liaison who must:

(i) Serve as the Federal awarding agency's management point of contact for the single audit process both within and outside the Federal Government.

(ii) Promote interagency coordination, consistency, and sharing in areas such as coordinating audit follow-up; identifying higher-risk non-Federal entities; providing input on single audit and follow-up policy; enhancing the utility of the FAC; and studying ways to use single audit results to improve Federal award accountability and best practices.

(iii) Oversee training for the Federal awarding agency's program management personnel related to the single audit process.

(iv) Promote the Federal awarding agency's use of cooperative audit resolution mechanisms.

(v) Coordinate the Federal awarding agency's activities to ensure appropriate and timely follow-up and corrective action on audit findings.

(vi) Organize the Federal cognizant agency for audit's follow-up on cross-cutting audit findings that affect the Federal programs of more than one Federal awarding agency.

(vii) Ensure the Federal awarding agency provides annual updates of the compliance supplement to OMB.

(viii) Support the Federal awarding agency's single audit accountable official's mission.

[78 FR 78608, Dec. 26, 2013, as amended at 79 FR 75887, Dec. 19, 2014]

[↑ Back to Top](#)

AUDITORS

[↑ Back to Top](#)

§200.514 Scope of audit.

(a) *General.* The audit must be conducted in accordance with GAGAS. The audit must cover the entire operations of the auditee, or, at the option of the auditee, such audit must include a series of audits that cover departments, agencies, and other organizational units that expended or otherwise administered Federal awards during such audit period, provided that each such audit must encompass the financial statements and schedule of expenditures of Federal awards for each such department, agency, and other organizational unit, which must be considered to be a non-Federal entity. The financial statements and schedule of expenditures of Federal awards must be for the same audit period.

(b) *Financial statements.* The auditor must determine whether the financial statements of the auditee are presented fairly in all material respects in accordance with generally accepted accounting principles. The auditor must also determine whether the schedule of expenditures of Federal awards is stated fairly in all material respects in relation to the auditee's financial statements as a whole.

(c) *Internal control.* (1) The compliance supplement provides guidance on internal controls over Federal programs based upon the guidance in Standards for Internal Control in the Federal Government issued by the Comptroller General of the United States and the Internal Control—Integrated Framework, issued by the Committee of Sponsoring Organizations of the Treadway Commission (COSO).

(2) In addition to the requirements of GAGAS, the auditor must perform procedures to obtain an understanding of internal control over Federal programs sufficient to plan the audit to support a low assessed level of control risk of noncompliance for major programs.

(3) Except as provided in paragraph (c)(4) of this section, the auditor must:

(i) Plan the testing of internal control over compliance for major programs to support a low assessed level of control risk for the assertions relevant to the compliance requirements for each major program; and

(ii) Perform testing of internal control as planned in paragraph (c)(3)(i) of this section.

(4) When internal control over some or all of the compliance requirements for a major program are likely to be ineffective in preventing or detecting noncompliance, the planning and performing of testing described in paragraph (c)(3) of this section are not required for those compliance requirements. However, the auditor must report a significant deficiency or material weakness in accordance with §200.516 Audit findings, assess the related control risk at the maximum, and consider whether additional compliance tests are required because of ineffective internal control.

(d) *Compliance.* (1) In addition to the requirements of GAGAS, the auditor must determine whether the auditee has complied with Federal statutes, regulations, and the terms and conditions of Federal awards that may have a direct and material effect on each of its major programs.

(2) The principal compliance requirements applicable to most Federal programs and the compliance requirements of the largest Federal programs are included in the compliance supplement.

(3) For the compliance requirements related to Federal programs contained in the compliance supplement, an audit of these compliance requirements will meet the requirements of this part. Where there have been changes to the compliance requirements and the changes are not reflected in the compliance supplement, the auditor must determine the current compliance requirements and modify the audit procedures accordingly. For those Federal programs not covered in the compliance supplement, the auditor must follow the compliance supplement's guidance for programs not included in the supplement.

(4) The compliance testing must include tests of transactions and such other auditing procedures necessary to provide the auditor sufficient appropriate audit evidence to support an opinion on compliance.

(e) *Audit follow-up.* The auditor must follow-up on prior audit findings, perform procedures to assess the reasonableness of the summary schedule of prior audit findings prepared by the auditee in accordance with §200.511 Audit findings follow-up paragraph (b), and report, as a current year audit finding, when the auditor concludes that the summary schedule of prior audit findings materially misrepresents the status of any prior audit finding. The auditor must perform audit follow-up procedures regardless of whether a prior audit finding relates to a major program in the current year.

(f) *Data Collection Form.* As required in §200.512 Report submission paragraph (b)(3), the auditor must complete and sign specified sections of the data collection form.

[78 FR 78608, Dec. 26, 2013, as amended at 79 FR 75887, Dec. 19, 2014]

[↑ Back to Top](#)

§200.515 Audit reporting.

The auditor's report(s) may be in the form of either combined or separate reports and may be organized differently from the manner presented in this section. The auditor's report(s) must state that the audit was conducted in accordance with this part and include the following:

(a) An opinion (or disclaimer of opinion) as to whether the financial statements are presented fairly in all material respects in accordance with generally accepted accounting principles and an opinion (or disclaimer of opinion) as to whether the schedule of expenditures of Federal awards is fairly stated in all material respects in relation to the financial statements as a whole.

(b) A report on internal control over financial reporting and compliance with provisions of laws, regulations, contracts, and award agreements, noncompliance with which could have a material effect on the financial statements. This report must describe the scope of testing of internal control and compliance and the results of the tests, and, where applicable, it will refer to the separate schedule of findings and questioned costs described in paragraph (d) of this section.

(c) A report on compliance for each major program and a report on internal control over compliance. This report must describe the scope of testing of internal control over compliance, include an opinion or disclaimer of opinion as to whether the auditee complied with Federal statutes, regulations, and the terms and conditions of Federal awards which could have a direct and material effect on each major program and refer to the separate schedule of findings and questioned costs described in paragraph (d) of this section.

(d) A schedule of findings and questioned costs which must include the following three components:

(1) A summary of the auditor's results, which must include:

- (i) The type of report the auditor issued on whether the financial statements audited were prepared in accordance with GAAP (i.e., unmodified opinion, qualified opinion, adverse opinion, or disclaimer of opinion);
 - (ii) Where applicable, a statement about whether significant deficiencies or material weaknesses in internal control were disclosed by the audit of the financial statements;
 - (iii) A statement as to whether the audit disclosed any noncompliance that is material to the financial statements of the auditee;
 - (iv) Where applicable, a statement about whether significant deficiencies or material weaknesses in internal control over major programs were disclosed by the audit;
 - (v) The type of report the auditor issued on compliance for major programs (i.e., unmodified opinion, qualified opinion, adverse opinion, or disclaimer of opinion);
 - (vi) A statement as to whether the audit disclosed any audit findings that the auditor is required to report under §200.516 Audit findings paragraph (a);
 - (vii) An identification of major programs by listing each individual major program; however in the case of a cluster of programs only the cluster name as shown on the Schedule of Expenditures of Federal Awards is required;
 - (viii) The dollar threshold used to distinguish between Type A and Type B programs, as described in §200.518 Major program determination paragraph (b)(1), or (b)(3) when a recalculation of the Type A threshold is required for large loan or loan guarantees; and
 - (ix) A statement as to whether the auditee qualified as a low-risk auditee under §200.520 Criteria for a low-risk auditee.
- (2) Findings relating to the financial statements which are required to be reported in accordance with GAGAS.
 - (3) Findings and questioned costs for Federal awards which must include audit findings as defined in §200.516 Audit findings, paragraph (a).
 - (i) Audit findings (e.g., internal control findings, compliance findings, questioned costs, or fraud) that relate to the same issue must be presented as a single audit finding. Where practical, audit findings should be organized by Federal agency or pass-through entity.
 - (ii) Audit findings that relate to both the financial statements and Federal awards, as reported under paragraphs (d)(2) and (d)(3) of this section, respectively, must be reported in both sections of the schedule. However, the reporting in one section of the schedule may be in summary form with a reference to a detailed reporting in the other section of the schedule.
- (e) Nothing in this part precludes combining of the audit reporting required by this section with the reporting required by §200.512 Report submission, paragraph (b) Data Collection when allowed by GAGAS and Appendix X to Part 200—Data Collection Form (Form SF-SAC).

[78 FR 78608, Dec. 26, 2013, as amended at 79 FR 75887, Dec. 19, 2014]

[Back to Top](#)

§200.516 Audit findings.

- (a) *Audit findings reported.* The auditor must report the following as audit findings in a schedule of findings and questioned costs:
 - (1) Significant deficiencies and material weaknesses in internal control over major programs and significant instances of abuse relating to major programs. The auditor's determination of whether a deficiency in internal control is a significant deficiency or material weakness for the purpose of reporting an audit finding is in relation to a type of compliance requirement for a major program identified in the Compliance Supplement.
 - (2) Material noncompliance with the provisions of Federal statutes, regulations, or the terms and conditions of Federal awards related to a major program. The auditor's determination of whether a noncompliance with the provisions of Federal statutes, regulations, or the terms and conditions of Federal awards is material for the purpose of reporting an audit finding is in relation to a type of compliance requirement for a major program identified in the compliance supplement.
 - (3) Known questioned costs that are greater than \$25,000 for a type of compliance requirement for a major program. Known questioned costs are those specifically identified by the auditor. In evaluating the effect of questioned costs on the opinion on compliance, the auditor considers the best estimate of total costs questioned (likely questioned costs), not just the questioned costs specifically identified (known questioned costs). The auditor must also report known questioned costs when likely questioned costs are greater than \$25,000 for a type of compliance requirement for a major program. In reporting questioned costs, the auditor must include information to provide proper perspective for judging the prevalence and consequences of the questioned costs.
 - (4) Known questioned costs that are greater than \$25,000 for a Federal program which is not audited as a major program. Except for audit follow-up, the auditor is not required under this part to perform audit procedures for such a Federal program; therefore, the auditor will normally not find questioned costs for a program that is not audited as a major program. However, if the auditor does become aware of questioned costs for a Federal program that is not audited as a major program (e.g., as part of audit follow-up or other audit procedures) and the known questioned costs are greater than \$25,000, then the auditor must report this as an audit finding.
 - (5) The circumstances concerning why the auditor's report on compliance for each major program is other than an unmodified opinion, unless such circumstances are otherwise reported as audit findings in the schedule of findings and questioned costs for Federal awards.
 - (6) Known or likely fraud affecting a Federal award, unless such fraud is otherwise reported as an audit finding in the schedule of findings and questioned costs for Federal awards. This paragraph does not require the auditor to report publicly information which could compromise investigative or legal proceedings or to make an additional reporting when the auditor confirms that the fraud was reported outside the auditor's reports under the direct reporting requirements of GAGAS.
 - (7) Instances where the results of audit follow-up procedures disclosed that the summary schedule of prior audit findings prepared by the auditee in accordance with §200.511 Audit findings follow-up, paragraph (b) materially misrepresents the status of any prior audit finding.

(b) *Audit finding detail and clarity.* Audit findings must be presented in sufficient detail and clarity for the auditee to prepare a corrective action plan and take corrective action, and for Federal agencies and pass-through entities to arrive at a management decision. The following specific information must be included, as applicable, in audit findings:

(1) Federal program and specific Federal award identification including the CFDA title and number, Federal award identification number and year, name of Federal agency, and name of the applicable pass-through entity. When information, such as the CFDA title and number or Federal award identification number, is not available, the auditor must provide the best information available to describe the Federal award.

(2) The criteria or specific requirement upon which the audit finding is based, including the Federal statutes, regulations, or the terms and conditions of the Federal awards. Criteria generally identify the required or desired state or expectation with respect to the program or operation. Criteria provide a context for evaluating evidence and understanding findings.

(3) The condition found, including facts that support the deficiency identified in the audit finding.

(4) A statement of cause that identifies the reason or explanation for the condition or the factors responsible for the difference between the situation that exists (condition) and the required or desired state (criteria), which may also serve as a basis for recommendations for corrective action.

(5) The possible asserted effect to provide sufficient information to the auditee and Federal agency, or pass-through entity in the case of a subrecipient, to permit them to determine the cause and effect to facilitate prompt and proper corrective action. A statement of the effect or potential effect should provide a clear, logical link to establish the impact or potential impact of the difference between the condition and the criteria.

(6) Identification of questioned costs and how they were computed. Known questioned costs must be identified by applicable CFDA number (s) and applicable Federal award identification number(s).

(7) Information to provide proper perspective for judging the prevalence and consequences of the audit findings, such as whether the audit findings represent an isolated instance or a systemic problem. Where appropriate, instances identified must be related to the universe and the number of cases examined and be quantified in terms of dollar value. The auditor should report whether the sampling was a statistically valid sample.

(8) Identification of whether the audit finding was a repeat of a finding in the immediately prior audit and if so any applicable prior year audit finding numbers.

(9) Recommendations to prevent future occurrences of the deficiency identified in the audit finding.

(10) Views of responsible officials of the auditee.

(c) *Reference numbers.* Each audit finding in the schedule of findings and questioned costs must include a reference number in the format meeting the requirements of the data collection form submission required by §200.512 Report submission, paragraph (b) to allow for easy referencing of the audit findings during follow-up.

[↑ Back to Top](#)

§200.517 Audit documentation.

(a) *Retention of audit documentation.* The auditor must retain audit documentation and reports for a minimum of three years after the date of issuance of the auditor's report(s) to the auditee, unless the auditor is notified in writing by the cognizant agency for audit, oversight agency for audit, cognizant agency for indirect costs, or pass-through entity to extend the retention period. When the auditor is aware that the Federal agency, pass-through entity, or auditee is contesting an audit finding, the auditor must contact the parties contesting the audit finding for guidance prior to destruction of the audit documentation and reports.

(b) *Access to audit documentation.* Audit documentation must be made available upon request to the cognizant or oversight agency for audit or its designee, cognizant agency for indirect cost, a Federal agency, or GAO at the completion of the audit, as part of a quality review, to resolve audit findings, or to carry out oversight responsibilities consistent with the purposes of this part. Access to audit documentation includes the right of Federal agencies to obtain copies of audit documentation, as is reasonable and necessary.

[↑ Back to Top](#)

§200.518 Major program determination.

(a) *General.* The auditor must use a risk-based approach to determine which Federal programs are major programs. This risk-based approach must include consideration of: current and prior audit experience, oversight by Federal agencies and pass-through entities, and the inherent risk of the Federal program. The process in paragraphs (b) through (h) of this section must be followed.

(b) *Step one.*(1) The auditor must identify the larger Federal programs, which must be labeled Type A programs. Type A programs are defined as Federal programs with Federal awards expended during the audit period exceeding the levels outlined in the table in this paragraph (b)(1):

Total Federal awards expended	Type A/B threshold
Equal to or exceed \$750,000 but less than or equal to \$25 million	\$750,000.
Exceed \$25 million but less than or equal to \$100 million	Total Federal awards expended times .03.
Exceed \$100 million but less than or equal to \$1 billion	\$3 million.
Exceed \$1 billion but less than or equal to \$10 billion	Total Federal awards expended times .003.
Exceed \$10 billion but less than or equal to \$20 billion	\$30 million.
Exceed \$20 billion	Total Federal awards expended times .0015.

(2) Federal programs not labeled Type A under paragraph (b)(1) of this section must be labeled Type B programs.

(3) The inclusion of large loan and loan guarantees (loans) must not result in the exclusion of other programs as Type A programs. When a Federal program providing loans exceeds four times the largest non-loan program it is considered a large loan program, and the auditor must

consider this Federal program as a Type A program and exclude its values in determining other Type A programs. This recalculation of the Type A program is performed after removing the total of all large loan programs. For the purposes of this paragraph a program is only considered to be a Federal program providing loans if the value of Federal awards expended for loans within the program comprises fifty percent or more of the total Federal awards expended for the program. A cluster of programs is treated as one program and the value of Federal awards expended under a loan program is determined as described in §200.502 Basis for determining Federal awards *expended*.

(4) For biennial audits permitted under §200.504 Frequency of audits, the determination of Type A and Type B programs must be based upon the Federal awards expended during the two-year period.

(c) *Step two.* (1) The auditor must identify Type A programs which are low-risk. In making this determination, the auditor must consider whether the requirements in §200.519 Criteria for Federal program risk paragraph (c), the results of audit follow-up, or any changes in personnel or systems affecting the program indicate significantly increased risk and preclude the program from being low risk. For a Type A program to be considered low-risk, it must have been audited as a major program in at least one of the two most recent audit periods (in the most recent audit period in the case of a biennial audit), and, in the most recent audit period, the program must have not had:

(i) Internal control deficiencies which were identified as material weaknesses in the auditor's report on internal control for major programs as required under §200.515 Audit reporting, paragraph (c);

(ii) A modified opinion on the program in the auditor's report on major programs as required under §200.515 Audit reporting, paragraph (c); or

(iii) Known or likely questioned costs that exceed five percent of the total Federal awards expended for the program.

(2) Notwithstanding paragraph (c)(1) of this section, OMB may approve a Federal awarding agency's request that a Type A program may not be considered low risk for a certain recipient. For example, it may be necessary for a large Type A program to be audited as a major program each year at a particular recipient to allow the Federal awarding agency to comply with 31 U.S.C. 3515. The Federal awarding agency must notify the recipient and, if known, the auditor of OMB's approval at least 180 calendar days prior to the end of the fiscal year to be audited.

(d) *Step three.* (1) The auditor must identify Type B programs which are high-risk using professional judgment and the criteria in §200.519 Criteria for Federal program risk. However, the auditor is not required to identify more high-risk Type B programs than at least one fourth the number of low-risk Type A programs identified as low-risk under Step 2 (paragraph (c) of this section). Except for known material weakness in internal control or compliance problems as discussed in §200.519 Criteria for Federal program risk paragraphs (b)(1), (b)(2), and (c)(1), a single criteria in risk would seldom cause a Type B program to be considered high-risk. When identifying which Type B programs to risk assess, the auditor is encouraged to use an approach which provides an opportunity for different high-risk Type B programs to be audited as major over a period of time.

(2) The auditor is not expected to perform risk assessments on relatively small Federal programs. Therefore, the auditor is only required to perform risk assessments on Type B programs that exceed twenty-five percent (0.25) of the Type A threshold determined in Step 1 (paragraph (b) of this section).

(e) *Step four.* At a minimum, the auditor must audit all of the following as major programs:

(1) All Type A programs not identified as low risk under step two (paragraph (c)(1) of this section).

(2) All Type B programs identified as high-risk under step three (paragraph (d) of this section).

(3) Such additional programs as may be necessary to comply with the percentage of coverage rule discussed in paragraph (f) of this section. This may require the auditor to audit more programs as major programs than the number of Type A programs.

(f) *Percentage of coverage rule.* If the additee meets the criteria in §200.520 Criteria for a low-risk additee, the auditor need only audit the major programs identified in Step 4 (paragraph (e)(1) and (2) of this section) and such additional Federal programs with Federal awards expended that, in aggregate, all major programs encompass at least 20 percent (0.20) of total Federal awards expended. Otherwise, the auditor must audit the major programs identified in Step 4 (paragraphs (e)(1) and (2) of this section) and such additional Federal programs with Federal awards expended that, in aggregate, all major programs encompass at least 40 percent (0.40) of total Federal awards expended.

(g) *Documentation of risk.* The auditor must include in the audit documentation the risk analysis process used in determining major programs.

(h) *Auditor's judgment.* When the major program determination was performed and documented in accordance with this Subpart, the auditor's judgment in applying the risk-based approach to determine major programs must be presumed correct. Challenges by Federal agencies and pass-through entities must only be for clearly improper use of the requirements in this part. However, Federal agencies and pass-through entities may provide auditors guidance about the risk of a particular Federal program and the auditor must consider this guidance in determining major programs in audits not yet completed.

[78 FR 78608, Dec. 26, 2013, as amended at 79 FR 75887, Dec. 19, 2014]

[Back to Top](#)

§200.519 Criteria for Federal program risk.

(a) *General.* The auditor's determination should be based on an overall evaluation of the risk of noncompliance occurring that could be material to the Federal program. The auditor must consider criteria, such as described in paragraphs (b), (c), and (d) of this section, to identify risk in Federal programs. Also, as part of the risk analysis, the auditor may wish to discuss a particular Federal program with additee management and the Federal agency or pass-through entity.

(b) *Current and prior audit experience.* (1) Weaknesses in internal control over Federal programs would indicate higher risk. Consideration should be given to the control environment over Federal programs and such factors as the expectation of management's adherence to Federal statutes, regulations, and the terms and conditions of Federal awards and the competence and experience of personnel who administer the Federal programs.

(i) A Federal program administered under multiple internal control structures may have higher risk. When assessing risk in a large single audit, the auditor must consider whether weaknesses are isolated in a single operating unit (e.g., one college campus) or pervasive throughout the entity.

(ii) When significant parts of a Federal program are passed through to subrecipients, a weak system for monitoring subrecipients would indicate higher risk.

(2) Prior audit findings would indicate higher risk, particularly when the situations identified in the audit findings could have a significant impact on a Federal program or have not been corrected.

(3) Federal programs not recently audited as major programs may be of higher risk than Federal programs recently audited as major programs without audit findings.

(c) *Oversight exercised by Federal agencies and pass-through entities.* (1) Oversight exercised by Federal agencies or pass-through entities could be used to assess risk. For example, recent monitoring or other reviews performed by an oversight entity that disclosed no significant problems would indicate lower risk, whereas monitoring that disclosed significant problems would indicate higher risk.

(2) Federal agencies, with the concurrence of OMB, may identify Federal programs that are higher risk. OMB will provide this identification in the compliance supplement.

(d) *Inherent risk of the Federal program.* (1) The nature of a Federal program may indicate risk. Consideration should be given to the complexity of the program and the extent to which the Federal program contracts for goods and services. For example, Federal programs that disburse funds through third party contracts or have eligibility criteria may be of higher risk. Federal programs primarily involving staff payroll costs may have high risk for noncompliance with requirements of §200.430 Compensation—personal services, but otherwise be at low risk.

(2) The phase of a Federal program in its life cycle at the Federal agency may indicate risk. For example, a new Federal program with new or interim regulations may have higher risk than an established program with time-tested regulations. Also, significant changes in Federal programs, statutes, regulations, or the terms and conditions of Federal awards may increase risk.

(3) The phase of a Federal program in its life cycle at the auditee may indicate risk. For example, during the first and last years that an auditee participates in a Federal program, the risk may be higher due to start-up or closeout of program activities and staff.

(4) Type B programs with larger Federal awards expended would be of higher risk than programs with substantially smaller Federal awards expended.

[↑ Back to Top](#)

§200.520 Criteria for a low-risk auditee.

An auditee that meets all of the following conditions for each of the preceding two audit periods must qualify as a low-risk auditee and be eligible for reduced audit coverage in accordance with §200.518 Major program determination.

(a) Single audits were performed on an annual basis in accordance with the provisions of this Subpart, including submitting the data collection form and the reporting package to the FAC within the timeframe specified in §200.512 Report submission. A non-Federal entity that has biennial audits does not qualify as a low-risk auditee.

(b) The auditor's opinion on whether the financial statements were prepared in accordance with GAAP, or a basis of accounting required by state law, and the auditor's in relation to opinion on the schedule of expenditures of Federal awards were unmodified.

(c) There were no deficiencies in internal control which were identified as material weaknesses under the requirements of GAGAS.

(d) The auditor did not report a substantial doubt about the auditee's ability to continue as a going concern.

(e) None of the Federal programs had audit findings from any of the following in either of the preceding two audit periods in which they were classified as Type A programs:

(1) Internal control deficiencies that were identified as material weaknesses in the auditor's report on internal control for major programs as required under §200.515 Audit reporting, paragraph (c);

(2) A modified opinion on a major program in the auditor's report on major programs as required under §200.515 Audit reporting, paragraph (c); or

(3) Known or likely questioned costs that exceeded five percent of the total Federal awards expended for a Type A program during the audit period.

[↑ Back to Top](#)

MANAGEMENT DECISIONS

[↑ Back to Top](#)

§200.521 Management decision.

(a) *General.* The management decision must clearly state whether or not the audit finding is sustained, the reasons for the decision, and the expected auditee action to repay disallowed costs, make financial adjustments, or take other action. If the auditee has not completed corrective action, a timetable for follow-up should be given. Prior to issuing the management decision, the Federal agency or pass-through entity may request additional information or documentation from the auditee, including a request for auditor assurance related to the documentation, as a way of mitigating disallowed costs. The management decision should describe any appeal process available to the auditee. While not required, the Federal agency or pass-through entity may also issue a management decision on findings relating to the financial statements which are required to be reported in accordance with GAGAS.

(b) *Federal agency.* As provided in §200.513 Responsibilities, paragraph (a)(7), the cognizant agency for audit must be responsible for coordinating a management decision for audit findings that affect the programs of more than one Federal agency. As provided in §200.513 Responsibilities, paragraph (c)(3), a Federal awarding agency is responsible for issuing a management decision for findings that relate to Federal awards it makes to non-Federal entities.

(c) *Pass-through entity.* As provided in §200.331 Requirements for pass-through entities, paragraph (d), the pass-through entity must be responsible for issuing a management decision for audit findings that relate to Federal awards it makes to subrecipients.

(d) *Time requirements.* The Federal awarding agency or pass-through entity responsible for issuing a management decision must do so within six months of acceptance of the audit report by the FAC. The auditee must initiate and proceed with corrective action as rapidly as possible and corrective action should begin no later than upon receipt of the audit report.

(e) *Reference numbers.* Management decisions must include the reference numbers the auditor assigned to each audit finding in accordance with §200.516 Audit findings paragraph (c).

[↑ Back to Top](#)

Appendix I to Part 200—Full Text of Notice of Funding Opportunity

The full text of the notice of funding opportunity is organized in sections. The required format outlined in this appendix indicates immediately following the title of each section whether that section is required in every announcement or is a Federal awarding agency option. The format is designed so that similar types of information will appear in the same sections in announcements of different Federal funding opportunities. Toward that end, there is text in each of the following sections to describe the types of information that a Federal awarding agency would include in that section of an actual announcement.

A Federal awarding agency that wishes to include information that the format does not specifically discuss may address that subject in whatever section(s) is most appropriate. For example, if a Federal awarding agency chooses to address performance goals in the announcement, it might do so in the funding opportunity description, the application content, or the reporting requirements.

Similarly, when this format calls for a type of information to be in a particular section, a Federal awarding agency wishing to address that subject in other sections may elect to repeat the information in those sections or use cross references between the sections (there should be hyperlinks for cross-references in any electronic versions of the announcement). For example, a Federal awarding agency may want to include Section A information about the types of non-Federal entities who are eligible to apply. The format specifies a standard location for that information in Section C.1 but does not preclude repeating the information in Section A or creating a cross reference between Section A and C.1, as long as a potential applicant can find the information quickly and easily from the standard location.

The sections of the full text of the announcement are described in the following paragraphs.

A. PROGRAM DESCRIPTION—REQUIRED

This section contains the full program description of the funding opportunity. It may be as long as needed to adequately communicate to potential applicants the areas in which funding may be provided. It describes the Federal awarding agency's funding priorities or the technical or focus areas in which the Federal awarding agency intends to provide assistance. As appropriate, it may include any program history (e.g., whether this is a new program or a new or changed area of program emphasis). This section may communicate indicators of successful projects (e.g., if the program encourages collaborative efforts) and may include examples of projects that have been funded previously. This section also may include other information the Federal awarding agency deems necessary, and must at a minimum include citations for authorizing statutes and regulations for the funding opportunity.

B. FEDERAL AWARD INFORMATION—REQUIRED

This section provides sufficient information to help an applicant make an informed decision about whether to submit a proposal. Relevant information could include the total amount of funding that the Federal awarding agency expects to award through the announcement; the anticipated number of Federal awards; the expected amounts of individual Federal awards (which may be a range); the amount of funding per Federal award, on average, experienced in previous years; and the anticipated start dates and periods of performance for new Federal awards. This section also should address whether applications for renewal or supplementation of existing projects are eligible to compete with applications for new Federal awards.

This section also must indicate the type(s) of assistance instrument (e.g., grant, cooperative agreement) that may be awarded if applications are successful. If cooperative agreements may be awarded, this section either should describe the "substantial involvement" that the Federal awarding agency expects to have or should reference where the potential applicant can find that information (e.g., in the funding opportunity description in A. Program Description—Required or Federal award administration information in Section D. Application and Submission Information). If procurement contracts also may be awarded, this must be stated.

C. ELIGIBILITY INFORMATION

This section addresses the considerations or factors that determine applicant or application eligibility. This includes the eligibility of particular types of applicant organizations, any factors affecting the eligibility of the principal investigator or project director, and any criteria that make particular projects ineligible. Federal agencies should make clear whether an applicant's failure to meet an eligibility criterion by the time of an application deadline will result in the Federal awarding agency returning the application without review or, even though an application may be reviewed, will preclude the Federal awarding agency from making a Federal award. Key elements to be addressed are:

1. *Eligible Applicants—Required.* Announcements must clearly identify the types of entities that are eligible to apply. If there are no restrictions on eligibility, this section may simply indicate that all potential applicants are eligible. If there are restrictions on eligibility, it is important to be clear about the specific types of entities that are eligible, not just the types that are ineligible. For example, if the program is limited to nonprofit organizations subject to 26 U.S.C. 501(c)(3) of the tax code (26 U.S.C. 501(c)(3)), the announcement should say so. Similarly, it is better to state explicitly that Native American tribal organizations are eligible than to assume that they can unambiguously infer that from a statement that nonprofit organizations may apply. Eligibility also can be expressed by exception, (e.g., open to all types of domestic applicants other than individuals). This section should refer to any portion of Section D specifying documentation that must be submitted to support an eligibility determination (e.g., proof of 501(c)(3) status as determined by the Internal Revenue Service or an authorizing tribal resolution). To the extent that any funding restriction in Section D.6 could affect the eligibility of an applicant or project, the announcement must either restate that restriction in this section or provide a cross-reference to its description in Section D.6.

2. *Cost Sharing or Matching—Required.* Announcements must state whether there is required cost sharing, matching, or cost participation without which an application would be ineligible (if cost sharing is not required, the announcement must explicitly say so). Required cost sharing may be a certain percentage or amount, or may be in the form of contributions of specified items or activities (e.g., provision of equipment). It is important that the announcement be clear about any restrictions on the types of cost (e.g., in-kind contributions) that are acceptable as cost sharing. Cost sharing as an eligibility criterion includes requirements based in statute or regulation, as described in §200.306 Cost sharing or

matching of this Part. This section should refer to the appropriate portion(s) of section D. Application and Submission Information stating any pre-award requirements for submission of letters or other documentation to verify commitments to meet cost-sharing requirements if a Federal award is made.

3. *Other—Required, if applicable.* If there are other eligibility criteria (i.e., criteria that have the effect of making an application or project ineligible for Federal awards, whether referred to as “responsiveness” criteria, “go-no go” criteria, “threshold” criteria, or in other ways), must be clearly stated and must include a reference to the regulation of requirement that describes the restriction, as applicable. For example, if entities that have been found to be in violation of a particular Federal statute are ineligible, it is important to say so. This section must also state any limit on the number of applications an applicant may submit under the announcement and make clear whether the limitation is on the submitting organization, individual investigator/program director, or both. This section should also address any eligibility criteria for beneficiaries or for program participants other than Federal award recipients.

D. APPLICATION AND SUBMISSION INFORMATION

1. *Address to Request Application Package—Required.* Potential applicants must be told how to get application forms, kits, or other materials needed to apply (if this announcement contains everything needed, this section need only say so). An Internet address where the materials can be accessed is acceptable. However, since high-speed Internet access is not yet universally available for downloading documents, and applicants may have additional accessibility requirements, there also should be a way for potential applicants to request paper copies of materials, such as a U.S. Postal Service mailing address, telephone or FAX number, Telephone Device for the Deaf (TDD), Text Telephone (TTY) number, and/or Federal Information Relay Service (FIRS) number.

2. *Content and Form of Application Submission—Required.* This section must identify the required content of an application and the forms or formats that an applicant must use to submit it. If any requirements are stated elsewhere because they are general requirements that apply to multiple programs or funding opportunities, this section should refer to where those requirements may be found. This section also should include required forms or formats as part of the announcement or state where the applicant may obtain them.

This section should specifically address content and form or format requirements for:

i. Pre-applications, letters of intent, or white papers required or encouraged (see Section D.4), including any limitations on the number of pages or other formatting requirements similar to those for full applications.

ii. The application as a whole. For all submissions, this would include any limitations on the number of pages, font size and typeface, margins, paper size, number of copies, and sequence or assembly requirements. If electronic submission is permitted or required, this could include special requirements for formatting or signatures.

iii. Component pieces of the application (e.g., if all copies of the application must bear original signatures on the face page or the program narrative may not exceed 10 pages). This includes any pieces that may be submitted separately by third parties (e.g., references or letters confirming commitments from third parties that will be contributing a portion of any required cost sharing).

iv. Information that successful applicants must submit after notification of intent to make a Federal award, but prior to a Federal award. This could include evidence of compliance with requirements relating to human subjects or information needed to comply with the National Environmental Policy Act (NEPA) (42 U.S.C. 4321-4370h).

3. *Unique entity identifier and System for Award Management (SAM)—Required.*

This paragraph must state clearly that each applicant (unless the applicant is an individual or Federal awarding agency that is excepted from those requirements under 2 CFR §25.110(b) or (c), or has an exception approved by the Federal awarding agency under 2 CFR §25.110(d)) is required to: (i) Be registered in SAM before submitting its application; (ii) provide a valid unique entity identifier in its application; and (iii) continue to maintain an active SAM registration with current information at all times during which it has an active Federal award or an application or plan under consideration by a Federal awarding agency. It also must state that the Federal awarding agency may not make a Federal award to an applicant until the applicant has complied with all applicable unique entity identifier and SAM requirements and, if an applicant has not fully complied with the requirements by the time the Federal awarding agency is ready to make a Federal award, the Federal awarding agency may determine that the applicant is not qualified to receive a Federal award and use that determination as a basis for making a Federal award to another applicant.

4. *Submission Dates and Times—Required.* Announcements must identify due dates and times for all submissions. This includes not only the full applications but also any preliminary submissions (e.g., letters of intent, white papers, or pre-applications). It also includes any other submissions of information before Federal award that are separate from the full application. If the funding opportunity is a general announcement that is open for a period of time with no specific due dates for applications, this section should say so. Note that the information on dates that is included in this section also must appear with other overview information in a location preceding the full text of the announcement (see §200.203 Notices of funding opportunities of this Part).

Each type of submission should be designated as encouraged or required and, if required, any deadline date (or dates, if the Federal awarding agency plans more than one cycle of application submission, review, and Federal award under the announcement) should be specified. The announcement must state (or provide a reference to another document that states):

i. Any deadline in terms of a date and local time. If the due date falls on a Saturday, Sunday, or Federal holiday, the reporting package is due the next business day.

ii. What the deadline means (e.g., whether it is the date and time by which the Federal awarding agency must receive the application, the date by which the application must be postmarked, or something else) and how that depends, if at all, on the submission method (e.g., mail, electronic, or personal/courier delivery).

iii. The effect of missing a deadline (e.g., whether late applications are neither reviewed nor considered or are reviewed and considered under some circumstances).

iv. How the receiving Federal office determines whether an application or pre-application has been submitted before the deadline. This includes the form of acceptable proof of mailing or system-generated documentation of receipt date and time.

This section also may indicate whether, when, and in what form the applicant will receive an acknowledgement of receipt. This information should be displayed in ways that will be easy to understand and use. It can be difficult to extract all needed information from narrative paragraphs, even when they are well written. A tabular form for providing a summary of the information may help applicants for some programs and give them what effectively could be a checklist to verify the completeness of their application package before submission.

5. *Intergovernmental Review—Required, if applicable.* If the funding opportunity is subject to Executive Order 12372, “Intergovernmental Review of Federal Programs,” the notice must say so. In alerting applicants that they must contact their state’s Single Point of Contact (SPOC) to find out about and comply with the state’s process under Executive Order 12372, it may be useful to inform potential applicants that the names and addresses of the SPOCs are listed in the Office of Management and Budget’s Web site. www.whitehouse.gov/omb/grants/spoc.html.

6. *Funding Restrictions—Required.* Notices must include information on funding restrictions in order to allow an applicant to develop an application and budget consistent with program requirements. Examples are whether construction is an allowable activity, if there are any limitations on direct costs such as foreign travel or equipment purchases, and if there are any limits on indirect costs (or facilities and administrative costs). Applicants must be advised if Federal awards will not allow reimbursement of pre-Federal award costs.

7. *Other Submission Requirements— Required.* This section must address any other submission requirements not included in the other paragraphs of this section. This might include the format of submission, i.e., paper or electronic, for each type of required submission. Applicants should not be required to submit in more than one format and this section should indicate whether they may choose whether to submit applications in hard copy or electronically, may submit only in hard copy, or may submit only electronically.

This section also must indicate where applications (and any pre-applications) must be submitted if sent by postal mail, electronic means, or hand-delivery. For postal mail submission, this must include the name of an office, official, individual or function (e.g., application receipt center) and a complete mailing address. For electronic submission, this must include the URL or email address; whether a password(s) is required; whether particular software or other electronic capabilities are required; what to do in the event of system problems and a point of contact who will be available in the event the applicant experiences technical difficulties.¹

¹With respect to electronic methods for providing information about funding opportunities or accepting applicants’ submissions of information, each Federal awarding agency is responsible for compliance with Section 508 of the Rehabilitation Act of 1973 (29 U.S.C. 794d).

E. APPLICATION REVIEW INFORMATION

1. *Criteria—Required.* This section must address the criteria that the Federal awarding agency will use to evaluate applications. This includes the merit and other review criteria that evaluators will use to judge applications, including any statutory, regulatory, or other preferences (e.g., minority status or Native American tribal preferences) that will be applied in the review process. These criteria are distinct from eligibility criteria that are addressed before an application is accepted for review and any program policy or other factors that are applied during the selection process, after the review process is completed. The intent is to make the application process transparent so applicants can make informed decisions when preparing their applications to maximize fairness of the process. The announcement should clearly describe all criteria, including any sub-criteria. If criteria vary in importance, the announcement should specify the relative percentages, weights, or other means used to distinguish among them. For statutory, regulatory, or other preferences, the announcement should provide a detailed explanation of those preferences with an explicit indication of their effect (e.g., whether they result in additional points being assigned).

If an applicant’s proposed cost sharing will be considered in the review process (as opposed to being an eligibility criterion described in Section C.2), the announcement must specifically address how it will be considered (e.g., to assign a certain number of additional points to applicants who offer cost sharing, or to break ties among applications with equivalent scores after evaluation against all other factors). If cost sharing will not be considered in the evaluation, the announcement should say so, so that there is no ambiguity for potential applicants. Vague statements that cost sharing is encouraged, without clarification as to what that means, are unhelpful to applicants. It also is important that the announcement be clear about any restrictions on the types of cost (e.g., in-kind contributions) that are acceptable as cost sharing.

2. *Review and Selection Process—Required.* This section may vary in the level of detail provided. The announcement must list any program policy or other factors or elements, other than merit criteria, that the selecting official may use in selecting applications for Federal award (e.g., geographical dispersion, program balance, or diversity). The Federal awarding agency may also include other appropriate details. For example, this section may indicate who is responsible for evaluation against the merit criteria (e.g., peers external to the Federal awarding agency or Federal awarding agency personnel) and/or who makes the final selections for Federal awards. If there is a multi-phase review process (e.g., an external panel advising internal Federal awarding agency personnel who make final recommendations to the deciding official), the announcement may describe the phases. It also may include: the number of people on an evaluation panel and how it operates, the way reviewers are selected, reviewer qualifications, and the way that conflicts of interest are avoided. With respect to electronic methods for providing information about funding opportunities or accepting applicants’ submissions of information, each Federal awarding agency is responsible for compliance with Section 508 of the Rehabilitation Act of 1973 (29 U.S.C. 794d).

In addition, if the Federal awarding agency permits applicants to nominate suggested reviewers of their applications or suggest those they feel may be inappropriate due to a conflict of interest, that information should be included in this section.

3. *Anticipated Announcement and Federal Award Dates—Optional.* This section is intended to provide applicants with information they can use for planning purposes. If there is a single application deadline followed by the simultaneous review of all applications, the Federal awarding agency can include in this section information about the anticipated dates for announcing or notifying successful and unsuccessful applicants and for having Federal awards in place. If applications are received and evaluated on a “rolling” basis at different times during an extended period, it may be appropriate to give applicants an estimate of the time needed to process an application and notify the applicant of the Federal awarding agency’s decision.

F. FEDERAL AWARD ADMINISTRATION INFORMATION

1. *Federal Award Notices—Required.* This section must address what a successful applicant can expect to receive following selection. If the Federal awarding agency’s practice is to provide a separate notice stating that an application has been selected before it actually makes the Federal award, this section would be the place to indicate that the letter is not an authorization to begin performance (to the extent that it allows charging to Federal awards of pre-award costs at the non-Federal entity’s own risk). This section should indicate that the notice of Federal award signed by the grants officer (or equivalent) is the authorizing document, and whether it is provided through postal mail or by electronic means and to whom. It also may address the timing, form, and content of notifications to unsuccessful applicants. See also §200.210 Information contained in a Federal award.

2. *Administrative and National Policy Requirements—Required.* This section must identify the usual administrative and national policy requirements the Federal awarding agency’s Federal awards may include. Providing this information lets a potential applicant identify any requirements with which it would have difficulty complying if its application is successful. In those cases, early notification about the requirements allows the potential applicant to decide not to apply or to take needed actions before receiving the Federal award. The announcement need not include all of the terms and conditions of the Federal award, but may refer to a document (with information about how to obtain it) or Internet site where applicants can see the terms and conditions. If this funding opportunity will lead to Federal awards with some special terms and conditions that differ from the Federal awarding agency’s usual (sometimes called “general”) terms and conditions, this section should highlight those

special terms and conditions. Doing so will alert applicants that have received Federal awards from the Federal awarding agency previously and might not otherwise expect different terms and conditions. For the same reason, the announcement should inform potential applicants about special requirements that could apply to particular Federal awards after the review of applications and other information, based on the particular circumstances of the effort to be supported (e.g., if human subjects were to be involved or if some situations may justify special terms on intellectual property, data sharing or security requirements).

3. Reporting—Required. This section must include general information about the type (e.g., financial or performance), frequency, and means of submission (paper or electronic) of post-Federal award reporting requirements. Highlight any special reporting requirements for Federal awards under this funding opportunity that differ (e.g., by report type, frequency, form/format, or circumstances for use) from what the Federal awarding agency's Federal awards usually require.

G. FEDERAL AWARDING AGENCY CONTACT(S)—REQUIRED

The announcement must give potential applicants a point(s) of contact for answering questions or helping with problems while the funding opportunity is open. The intent of this requirement is to be as helpful as possible to potential applicants, so the Federal awarding agency should consider approaches such as giving:

- i. Points of contact who may be reached in multiple ways (e.g., by telephone, FAX, and/or email, as well as regular mail).
- ii. A fax or email address that multiple people access, so that someone will respond even if others are unexpectedly absent during critical periods.
- iii. Different contacts for distinct kinds of help (e.g., one for questions of programmatic content and a second for administrative questions).

H. OTHER INFORMATION—OPTIONAL

This section may include any additional information that will assist a potential applicant. For example, the section might:

- i. Indicate whether this is a new program or a one-time initiative.
- ii. Mention related programs or other upcoming or ongoing Federal awarding agency funding opportunities for similar activities.
- iii. Include current Internet addresses for Federal awarding agency Web sites that may be useful to an applicant in understanding the program.
- iv. Alert applicants to the need to identify proprietary information and inform them about the way the Federal awarding agency will handle it.
- v. Include certain routine notices to applicants (e.g., that the Federal Government is not obligated to make any Federal award as a result of the announcement or that only grants officers can bind the Federal Government to the expenditure of funds).

[Back to Top](#)

Appendix II to Part 200—Contract Provisions for Non-Federal Entity Contracts Under Federal Awards

In addition to other provisions required by the Federal agency or non-Federal entity, all contracts made by the non-Federal entity under the Federal award must contain provisions covering the following, as applicable.

(A) Contracts for more than the simplified acquisition threshold currently set at \$150,000, which is the inflation adjusted amount determined by the Civilian Agency Acquisition Council and the Defense Acquisition Regulations Council (Councils) as authorized by 41 U.S.C. 1908, must address administrative, contractual, or legal remedies in instances where contractors violate or breach contract terms, and provide for such sanctions and penalties as appropriate.

(B) All contracts in excess of \$10,000 must address termination for cause and for convenience by the non-Federal entity including the manner by which it will be effected and the basis for settlement.

(C) Equal Employment Opportunity. Except as otherwise provided under 41 CFR Part 60, all contracts that meet the definition of "federally assisted construction contract" in 41 CFR Part 60-1.3 must include the equal opportunity clause provided under 41 CFR 60-1.4(b), in accordance with Executive Order 11246, "Equal Employment Opportunity" (30 FR 12319, 12935, 3 CFR Part, 1964-1965 Comp., p. 339), as amended by Executive Order 11375, "Amending Executive Order 11246 Relating to Equal Employment Opportunity," and implementing regulations at 41 CFR part 60, "Office of Federal Contract Compliance Programs, Equal Employment Opportunity, Department of Labor."

(D) Davis-Bacon Act, as amended (40 U.S.C. 3141-3148). When required by Federal program legislation, all prime construction contracts in excess of \$2,000 awarded by non-Federal entities must include a provision for compliance with the Davis-Bacon Act (40 U.S.C. 3141-3144, and 3146-3148) as supplemented by Department of Labor regulations (29 CFR Part 5, "Labor Standards Provisions Applicable to Contracts Covering Federally Financed and Assisted Construction"). In accordance with the statute, contractors must be required to pay wages to laborers and mechanics at a rate not less than the prevailing wages specified in a wage determination made by the Secretary of Labor. In addition, contractors must be required to pay wages not less than once a week. The non-Federal entity must place a copy of the current prevailing wage determination issued by the Department of Labor in each solicitation. The decision to award a contract or subcontract must be conditioned upon the acceptance of the wage determination. The non-Federal entity must report all suspected or reported violations to the Federal awarding agency. The contracts must also include a provision for compliance with the Copeland "Anti-Kickback" Act (40 U.S.C. 3145), as supplemented by Department of Labor regulations (29 CFR Part 3, "Contractors and Subcontractors on Public Building or Public Work Financed in Whole or in Part by Loans or Grants from the United States"). The Act provides that each contractor or subrecipient must be prohibited from inducing, by any means, any person employed in the construction, completion, or repair of public work, to give up any part of the compensation to which he or she is otherwise entitled. The non-Federal entity must report all suspected or reported violations to the Federal awarding agency.

(E) Contract Work Hours and Safety Standards Act (40 U.S.C. 3701-3708). Where applicable, all contracts awarded by the non-Federal entity in excess of \$100,000 that involve the employment of mechanics or laborers must include a provision for compliance with 40 U.S.C. 3702 and 3704, as supplemented by Department of Labor regulations (29 CFR Part 5). Under 40 U.S.C. 3702 of the Act, each contractor must be required to compute the wages of every mechanic and laborer on the basis of a standard work week of 40 hours. Work in excess of the standard work week is permissible provided that the worker is compensated at a rate of not less than one and a half times the basic rate of pay for all hours worked in excess of 40 hours in the work week. The requirements of 40 U.S.C. 3704 are applicable to construction work and provide that no laborer or mechanic must be required to work in surroundings or under working conditions which are unsanitary, hazardous or dangerous.

These requirements do not apply to the purchases of supplies or materials or articles ordinarily available on the open market, or contracts for transportation or transmission of intelligence.

(F) Rights to Inventions Made Under a Contract or Agreement. If the Federal award meets the definition of “funding agreement” under 37 CFR §401.2 (a) and the recipient or subrecipient wishes to enter into a contract with a small business firm or nonprofit organization regarding the substitution of parties, assignment or performance of experimental, developmental, or research work under that “funding agreement,” the recipient or subrecipient must comply with the requirements of 37 CFR Part 401, “Rights to Inventions Made by Nonprofit Organizations and Small Business Firms Under Government Grants, Contracts and Cooperative Agreements,” and any implementing regulations issued by the awarding agency.

(G) Clean Air Act (42 U.S.C. 7401-7671q.) and the Federal Water Pollution Control Act (33 U.S.C. 1251-1387), as amended—Contracts and subgrants of amounts in excess of \$150,000 must contain a provision that requires the non-Federal award to agree to comply with all applicable standards, orders or regulations issued pursuant to the Clean Air Act (42 U.S.C. 7401-7671q) and the Federal Water Pollution Control Act as amended (33 U.S.C. 1251-1387). Violations must be reported to the Federal awarding agency and the Regional Office of the Environmental Protection Agency (EPA).

(H) Debarment and Suspension (Executive Orders 12549 and 12689)—A contract award (see 2 CFR 180.220) must not be made to parties listed on the governmentwide exclusions in the System for Award Management (SAM), in accordance with the OMB guidelines at 2 CFR 180 that implement Executive Orders 12549 (3 CFR part 1986 Comp., p. 189) and 12689 (3 CFR part 1989 Comp., p. 235), “Debarment and Suspension.” SAM Exclusions contains the names of parties debarred, suspended, or otherwise excluded by agencies, as well as parties declared ineligible under statutory or regulatory authority other than Executive Order 12549.

(I) Byrd Anti-Lobbying Amendment (31 U.S.C. 1352)—Contractors that apply or bid for an award exceeding \$100,000 must file the required certification. Each tier certifies to the tier above that it will not and has not used Federal appropriated funds to pay any person or organization for influencing or attempting to influence an officer or employee of any agency, a member of Congress, officer or employee of Congress, or an employee of a member of Congress in connection with obtaining any Federal contract, grant or any other award covered by 31 U.S.C. 1352. Each tier must also disclose any lobbying with non-Federal funds that takes place in connection with obtaining any Federal award. Such disclosures are forwarded from tier to tier up to the non-Federal award.

(J) See §200.322 Procurement of recovered materials.

[78 FR 78608, Dec. 26, 2013, as amended at 79 FR 75888, Dec. 19, 2014]

[↑ Back to Top](#)

Appendix III to Part 200—Indirect (F&A) Costs Identification and Assignment, and Rate Determination for Institutions of Higher Education (IHEs)

A. GENERAL

This appendix provides criteria for identifying and computing indirect (or indirect (F&A)) rates at IHEs (institutions). Indirect (F&A) costs are those that are incurred for common or joint objectives and therefore cannot be identified readily and specifically with a particular sponsored project, an instructional activity, or any other institutional activity. See subsection B.1, Definition of Facilities and Administration, for a discussion of the components of indirect (F&A) costs.

1. Major Functions of an Institution

Refers to instruction, organized research, other sponsored activities and other institutional activities as defined in this section:

a. *Instruction* means the teaching and training activities of an institution. Except for research training as provided in subsection b, this term includes all teaching and training activities, whether they are offered for credits toward a degree or certificate or on a non-credit basis, and whether they are offered through regular academic departments or separate divisions, such as a summer school division or an extension division. Also considered part of this major function are departmental research, and, where agreed to, university research.

(1) *Sponsored instruction and training* means specific instructional or training activity established by grant, contract, or cooperative agreement. For purposes of the cost principles, this activity may be considered a major function even though an institution’s accounting treatment may include it in the instruction function.

(2) *Departmental research* means research, development and scholarly activities that are not organized research and, consequently, are not separately budgeted and accounted for. Departmental research, for purposes of this document, is not considered as a major function, but as a part of the instruction function of the institution.

(3) Only mandatory cost sharing or cost sharing specifically committed in the project budget must be included in the organized research base for computing the indirect (F&A) cost rate or reflected in any allocation of indirect costs. Salary costs above statutory limits are not considered cost sharing.

b. *Organized research* means all research and development activities of an institution that are separately budgeted and accounted for. It includes:

(1) *Sponsored research* means all research and development activities that are sponsored by Federal and non-Federal agencies and organizations. This term includes activities involving the training of individuals in research techniques (commonly called research training) where such activities utilize the same facilities as other research and development activities and where such activities are not included in the instruction function.

(2) *University research* means all research and development activities that are separately budgeted and accounted for by the institution under an internal application of institutional funds. University research, for purposes of this document, must be combined with sponsored research under the function of organized research.

c. *Other sponsored activities* means programs and projects financed by Federal and non-Federal agencies and organizations which involve the performance of work other than instruction and organized research. Examples of such programs and projects are health service projects and community service programs. However, when any of these activities are undertaken by the institution without outside support, they may be classified as other institutional activities.

d. *Other institutional activities* means all activities of an institution except for instruction, departmental research, organized research, and other sponsored activities, as defined in this section; indirect (F&A) cost activities identified in this Appendix paragraph B, Identification and assignment of indirect (F&A) costs; and specialized services facilities described in §200.468 Specialized service facilities of this Part.

Examples of other institutional activities include operation of residence halls, dining halls, hospitals and clinics, student unions, intercollegiate athletics, bookstores, faculty housing, student apartments, guest houses, chapels, theaters, public museums, and other similar auxiliary enterprises. This definition also includes any other categories of activities, costs of which are "unallowable" to Federal awards, unless otherwise indicated in an award.

2. Criteria for Distribution

a. *Base period.* A base period for distribution of indirect (F&A) costs is the period during which the costs are incurred. The base period normally should coincide with the fiscal year established by the institution, but in any event the base period should be so selected as to avoid inequities in the distribution of costs.

b. *Need for cost groupings.* The overall objective of the indirect (F&A) cost allocation process is to distribute the indirect (F&A) costs described in Section B, Identification and assignment of indirect (F&A) costs, to the major functions of the institution in proportions reasonably consistent with the nature and extent of their use of the institution's resources. In order to achieve this objective, it may be necessary to provide for selective distribution by establishing separate groupings of cost within one or more of the indirect (F&A) cost categories referred to in subsection B.1, Definition of Facilities and Administration. In general, the cost groupings established within a category should constitute, in each case, a pool of those items of expense that are considered to be of like nature in terms of their relative contribution to (or degree of remoteness from) the particular cost objectives to which distribution is appropriate. Cost groupings should be established considering the general guides provided in subsection c of this section. Each such pool or cost grouping should then be distributed individually to the related cost objectives, using the distribution base or method most appropriate in light of the guidelines set forth in subsection d of this section.

c. *General considerations on cost groupings.* The extent to which separate cost groupings and selective distribution would be appropriate at an institution is a matter of judgment to be determined on a case-by-case basis. Typical situations which may warrant the establishment of two or more separate cost groupings (based on account classification or analysis) within an indirect (F&A) cost category include but are not limited to the following:

(1) If certain items or categories of expense relate solely to one of the major functions of the institution or to less than all functions, such expenses should be set aside as a separate cost grouping for direct assignment or selective allocation in accordance with the guides provided in subsections b and d.

(2) If any types of expense ordinarily treated as general administration or departmental administration are charged to Federal awards as direct costs, expenses applicable to other activities of the institution when incurred for the same purposes in like circumstances must, through separate cost groupings, be excluded from the indirect (F&A) costs allocable to those Federal awards and included in the direct cost of other activities for cost allocation purposes.

(3) If it is determined that certain expenses are for the support of a service unit or facility whose output is susceptible of measurement on a workload or other quantitative basis, such expenses should be set aside as a separate cost grouping for distribution on such basis to organized research, instructional, and other activities at the institution or within the department.

(4) If activities provide their own purchasing, personnel administration, building maintenance or similar service, the distribution of general administration and general expenses, or operation and maintenance expenses to such activities should be accomplished through cost groupings which include only that portion of central indirect (F&A) costs (such as for overall management) which are properly allocable to such activities.

(5) If the institution elects to treat fringe benefits as indirect (F&A) charges, such costs should be set aside as a separate cost grouping for selective distribution to related cost objectives.

(6) The number of separate cost groupings within a category should be held within practical limits, after taking into consideration the materiality of the amounts involved and the degree of precision attainable through less selective methods of distribution.

d. Selection of distribution method.

(1) Actual conditions must be taken into account in selecting the method or base to be used in distributing individual cost groupings. The essential consideration in selecting a base is that it be the one best suited for assigning the pool of costs to cost objectives in accordance with benefits derived; with a traceable cause-and-effect relationship; or with logic and reason, where neither benefit nor a cause-and-effect relationship is determinable.

(2) If a cost grouping can be identified directly with the cost objective benefitted, it should be assigned to that cost objective.

(3) If the expenses in a cost grouping are more general in nature, the distribution may be based on a cost analysis study which results in an equitable distribution of the costs. Such cost analysis studies may take into consideration weighting factors, population, or space occupied if appropriate. Cost analysis studies, however, must (a) be appropriately documented in sufficient detail for subsequent review by the cognizant agency for indirect costs, (b) distribute the costs to the related cost objectives in accordance with the relative benefits derived, (c) be statistically sound, (d) be performed specifically at the institution at which the results are to be used, and (e) be reviewed periodically, but not less frequently than rate negotiations, updated if necessary, and used consistently. Any assumptions made in the study must be stated and explained. The use of cost analysis studies and periodic changes in the method of cost distribution must be fully justified.

(4) If a cost analysis study is not performed, or if the study does not result in an equitable distribution of the costs, the distribution must be made in accordance with the appropriate base cited in Section B, Identification and assignment of indirect (F&A) costs, unless one of the following conditions is met:

(a) It can be demonstrated that the use of a different base would result in a more equitable allocation of the costs, or that a more readily available base would not increase the costs charged to Federal awards, or

(b) The institution qualifies for, and elects to use, the simplified method for computing indirect (F&A) cost rates described in Section D, Simplified method for small institutions.

(5) Notwithstanding subsection (3), effective July 1, 1998, a cost analysis or base other than that in Section B must not be used to distribute utility or student services costs. Instead, subsections B.4.c Operation and maintenance expenses, may be used in the recovery of utility costs.

e. Order of distribution.

(1) Indirect (F&A) costs are the broad categories of costs discussed in Section B.1, Definitions of Facilities and Administration

(2) Depreciation, interest expenses, operation and maintenance expenses, and general administrative and general expenses should be allocated in that order to the remaining indirect (F&A) cost categories as well as to the major functions and specialized service facilities of the institution. Other cost categories may be allocated in the order determined to be most appropriate by the institutions. When cross allocation of costs is made as provided in subsection (3), this order of allocation does not apply.

(3) Normally an indirect (F&A) cost category will be considered closed once it has been allocated to other cost objectives, and costs may not be subsequently allocated to it. However, a cross allocation of costs between two or more indirect (F&A) cost categories may be used if such allocation will result in a more equitable allocation of costs. If a cross allocation is used, an appropriate modification to the composition of the indirect (F&A) cost categories described in Section B is required.

B. IDENTIFICATION AND ASSIGNMENT OF INDIRECT (F&A) COSTS

1. Definition of Facilities and Administration

See §200.414 Indirect (F&A) costs which provides the basis for these indirect cost requirements.

2. Depreciation

a. The expenses under this heading are the portion of the costs of the institution's buildings, capital improvements to land and buildings, and equipment which are computed in accordance with §200.436 Depreciation.

b. In the absence of the alternatives provided for in Section A.2.d, Selection of distribution method, the expenses included in this category must be allocated in the following manner:

(1) Depreciation on buildings used exclusively in the conduct of a single function, and on capital improvements and equipment used in such buildings, must be assigned to that function.

(2) Depreciation on buildings used for more than one function, and on capital improvements and equipment used in such buildings, must be allocated to the individual functions performed in each building on the basis of usable square feet of space, excluding common areas such as hallways, stairwells, and rest rooms.

(3) Depreciation on buildings, capital improvements and equipment related to space (e.g., individual rooms, laboratories) used jointly by more than one function (as determined by the users of the space) must be treated as follows. The cost of each jointly used unit of space must be allocated to benefitting functions on the basis of:

(a) The employee full-time equivalents (FTEs) or salaries and wages of those individual functions benefitting from the use of that space; or

(b) Institution-wide employee FTEs or salaries and wages applicable to the benefitting major functions (see Section A.1) of the institution.

(4) Depreciation on certain capital improvements to land, such as paved parking areas, fences, sidewalks, and the like, not included in the cost of buildings, must be allocated to user categories of students and employees on a full-time equivalent basis. The amount allocated to the student category must be assigned to the instruction function of the institution. The amount allocated to the employee category must be further allocated to the major functions of the institution in proportion to the salaries and wages of all employees applicable to those functions.

3. Interest

Interest on debt associated with certain buildings, equipment and capital improvements, as defined in §200.449 Interest, must be classified as an expenditure under the category Facilities. These costs must be allocated in the same manner as the depreciation on the buildings, equipment and capital improvements to which the interest relates.

4. Operation and Maintenance Expenses

a. The expenses under this heading are those that have been incurred for the administration, supervision, operation, maintenance, preservation, and protection of the institution's physical plant. They include expenses normally incurred for such items as janitorial and utility services; repairs and ordinary or normal alterations of buildings, furniture and equipment; care of grounds; maintenance and operation of buildings and other plant facilities; security; earthquake and disaster preparedness; environmental safety; hazardous waste disposal; property, liability and all other insurance relating to property; space and capital leasing; facility planning and management; and central receiving. The operation and maintenance expense category should also include its allocable share of fringe benefit costs, depreciation, and interest costs.

b. In the absence of the alternatives provided for in Section A.2.d, the expenses included in this category must be allocated in the same manner as described in subsection 2.b for depreciation.

c. A utility cost adjustment of up to 1.3 percentage points may be included in the negotiated indirect cost rate of the IHE for organized research, per the computation alternatives in paragraphs (c)(1) and (2) of this section:

(1) Where space is devoted to a single function and metering allows unambiguous measurement of usage related to that space, costs must be assigned to the function located in that space.

(2) Where space is allocated to different functions and metering does not allow unambiguous measurement of usage by function, costs must be allocated as follows:

(i) Utilities costs should be apportioned to functions in the same manner as depreciation, based on the calculated difference between the site or building actual square footage for monitored research laboratory space (site, building, floor, or room), and a separate calculation prepared by the IHE using the "effective square footage" described in subsection (c)(2)(ii) of this section.

(ii) "Effective square footage" allocated to research laboratory space must be calculated as the actual square footage times the relative energy utilization index (REUI) posted on the OMB Web site at the time of a rate determination.

A. This index is the ratio of a laboratory energy use index (lab EUI) to the corresponding index for overall average college or university space (college EUI).

B. In July 2012, values for these two indices (taken respectively from the Lawrence Berkeley Laboratory "Labs for the 21st Century" benchmarking tool <http://labs21benchmarking.lbl.gov/CompareData.php> and the US Department of Energy "Buildings Energy Databook" and <http://buildingsdatabook.eren.doe.gov/CBECS.aspx>) were 310 kBtu/sq ft-yr. and 155 kBtu/sq ft-yr., so that the adjustment ratio is 2.0 by this methodology. To retain currency, OMB will adjust the EUI numbers from time to time (no more often than annually nor less often than every 5 years), using reliable and publicly disclosed data. Current values of both the EUIs and the REUI will be posted on the OMB Web site.

5. General Administration and General Expenses

a. The expenses under this heading are those that have been incurred for the general executive and administrative offices of educational institutions and other expenses of a general character which do not relate solely to any major function of the institution; i.e., solely to (1) instruction, (2) organized research, (3) other sponsored activities, or (4) other institutional activities. The general administration and general expense category should also include its allocable share of fringe benefit costs, operation and maintenance expense, depreciation, and interest costs. Examples of general administration and general expenses include: those expenses incurred by administrative offices that serve the entire university system of which the institution is a part; central offices of the institution such as the President's or Chancellor's office, the offices for institution-wide financial management, business services, budget and planning, personnel management, and safety and risk management; the office of the General Counsel; and the operations of the central administrative management information systems. General administration and general expenses must not include expenses incurred within non-university-wide deans' offices, academic departments, organized research units, or similar organizational units. (See subsection 6, Departmental administration expenses.)

b. In the absence of the alternatives provided for in Section A.2.d, the expenses included in this category must be grouped first according to common major functions of the institution to which they render services or provide benefits. The aggregate expenses of each group must then be allocated to serviced or benefitted functions on the modified total cost basis. Modified total costs consist of the same elements as those in Section C.2. When an activity included in this indirect (F&A) cost category provides a service or product to another institution or organization, an appropriate adjustment must be made to either the expenses or the basis of allocation or both, to assure a proper allocation of costs.

6. Departmental Administration Expenses

a. The expenses under this heading are those that have been incurred for administrative and supporting services that benefit common or joint departmental activities or objectives in academic deans' offices, academic departments and divisions, and organized research units. Organized research units include such units as institutes, study centers, and research centers. Departmental administration expenses are subject to the following limitations.

(1) Academic deans' offices. Salaries and operating expenses are limited to those attributable to administrative functions.

(2) Academic departments:

(a) Salaries and fringe benefits attributable to the administrative work (including bid and proposal preparation) of faculty (including department heads) and other professional personnel conducting research and/or instruction, must be allowed at a rate of 3.6 percent of modified total direct costs. This category does not include professional business or professional administrative officers. This allowance must be added to the computation of the indirect (F&A) cost rate for major functions in Section C, Determination and application of indirect (F&A) cost rate or rates; the expenses covered by the allowance must be excluded from the departmental administration cost pool. No documentation is required to support this allowance.

(b) Other administrative and supporting expenses incurred within academic departments are allowable provided they are treated consistently in like circumstances. This would include expenses such as the salaries of secretarial and clerical staffs, the salaries of administrative officers and assistants, travel, office supplies, stockrooms, and the like.

(3) Other fringe benefit costs applicable to the salaries and wages included in subsections (1) and (2) are allowable, as well as an appropriate share of general administration and general expenses, operation and maintenance expenses, and depreciation.

(4) Federal agencies may authorize reimbursement of additional costs for department heads and faculty only in exceptional cases where an institution can demonstrate undue hardship or detriment to project performance.

b. The following guidelines apply to the determination of departmental administrative costs as direct or indirect (F&A) costs.

(1) In developing the departmental administration cost pool, special care should be exercised to ensure that costs incurred for the same purpose in like circumstances are treated consistently as either direct or indirect (F&A) costs. For example, salaries of technical staff, laboratory supplies (e.g., chemicals), telephone toll charges, animals, animal care costs, computer costs, travel costs, and specialized shop costs must be treated as direct costs wherever identifiable to a particular cost objective. Direct charging of these costs may be accomplished through specific identification of individual costs to benefitting cost objectives, or through recharge centers or specialized service facilities, as appropriate under the circumstances. See §§200.413 Direct costs, paragraph (c) and 200.468 Specialized service facilities.

(2) Items such as office supplies, postage, local telephone costs, and memberships must normally be treated as indirect (F&A) costs.

c. In the absence of the alternatives provided for in Section A.2.d, the expenses included in this category must be allocated as follows:

(1) The administrative expenses of the dean's office of each college and school must be allocated to the academic departments within that college or school on the modified total cost basis.

(2) The administrative expenses of each academic department, and the department's share of the expenses allocated in subsection (1) must be allocated to the appropriate functions of the department on the modified total cost basis.

7. Sponsored Projects Administration

a. The expenses under this heading are limited to those incurred by a separate organization(s) established primarily to administer sponsored projects, including such functions as grant and contract administration (Federal and non-Federal), special security, purchasing, personnel, administration, and editing and publishing of research and other reports. They include the salaries and expenses of the head of such organization, assistants, and immediate staff, together with the salaries and expenses of personnel engaged in supporting activities maintained by the organization, such as stock rooms, print shops, and the like. This category also includes an allocable share of fringe benefit costs, general administration and general expenses, operation and maintenance expenses, and depreciation. Appropriate adjustments will be made for services provided to other functions or organizations.

b. In the absence of the alternatives provided for in Section A.2.d, the expenses included in this category must be allocated to the major functions of the institution under which the sponsored projects are conducted on the basis of the modified total cost of sponsored projects.

c. An appropriate adjustment must be made to eliminate any duplicate charges to Federal awards when this category includes similar or identical activities as those included in the general administration and general expense category or other indirect (F&A) cost items, such as accounting, procurement, or personnel administration.

8. Library Expenses

a. The expenses under this heading are those that have been incurred for the operation of the library, including the cost of books and library materials purchased for the library, less any items of library income that qualify as applicable credits under §200.406 Applicable credits. The library expense category should also include the fringe benefits applicable to the salaries and wages included therein, an appropriate share of general administration and general expense, operation and maintenance expense, and depreciation. Costs incurred in the purchases of rare books (museum-type books) with no value to Federal awards should not be allocated to them.

b. In the absence of the alternatives provided for in Section A.2.d, the expenses included in this category must be allocated first on the basis of primary categories of users, including students, professional employees, and other users.

(1) The student category must consist of full-time equivalent students enrolled at the institution, regardless of whether they earn credits toward a degree or certificate.

(2) The professional employee category must consist of all faculty members and other professional employees of the institution, on a full-time equivalent basis. This category may also include post-doctorate fellows and graduate students.

(3) The other users category must consist of a reasonable factor as determined by institutional records to account for all other users of library facilities.

c. Amount allocated in paragraph b of this section must be assigned further as follows:

(1) The amount in the student category must be assigned to the instruction function of the institution.

(2) The amount in the professional employee category must be assigned to the major functions of the institution in proportion to the salaries and wages of all faculty members and other professional employees applicable to those functions.

(3) The amount in the other users category must be assigned to the other institutional activities function of the institution.

9. Student Administration and Services

a. The expenses under this heading are those that have been incurred for the administration of student affairs and for services to students, including expenses of such activities as deans of students, admissions, registrar, counseling and placement services, student advisers, student health and infirmary services, catalogs, and commencements and convocations. The salaries of members of the academic staff whose responsibilities to the institution require administrative work that benefits sponsored projects may also be included to the extent that the portion charged to student administration is determined in accordance with Subpart E—Cost Principles of this Part. This expense category also includes the fringe benefit costs applicable to the salaries and wages included therein, an appropriate share of general administration and general expenses, operation and maintenance, interest expense, and depreciation.

b. In the absence of the alternatives provided for in Section A.2.d, the expenses in this category must be allocated to the instruction function, and subsequently to Federal awards in that function.

10. Offset for Indirect (F&A) Expenses Otherwise Provided for by the Federal Government

a. The items to be accumulated under this heading are the reimbursements and other payments from the Federal Government which are made to the institution to support solely, specifically, and directly, in whole or in part, any of the administrative or service activities described in subsections 2 through 9.

b. The items in this group must be treated as a credit to the affected individual indirect (F&A) cost category before that category is allocated to benefitting functions.

C. DETERMINATION AND APPLICATION OF INDIRECT (F&A) COST RATE OR RATES

1. Indirect (F&A) Cost Pools

a. (1) Subject to subsection b, the separate categories of indirect (F&A) costs allocated to each major function of the institution as prescribed in paragraph B of this paragraph C.1 Identification and assignment of indirect (F&A) costs, must be aggregated and treated as a common pool for that function. The amount in each pool must be divided by the distribution base described in subsection 2 to arrive at a single indirect (F&A) cost rate for each function.

(2) The rate for each function is used to distribute indirect (F&A) costs to individual Federal awards of that function. Since a common pool is established for each major function of the institution, a separate indirect (F&A) cost rate would be established for each of the major functions described in Section A.1 under which Federal awards are carried out.

(3) Each institution's indirect (F&A) cost rate process must be appropriately designed to ensure that Federal sponsors do not in any way subsidize the indirect (F&A) costs of other sponsors, specifically activities sponsored by industry and foreign governments. Accordingly, each allocation method used to identify and allocate the indirect (F&A) cost pools, as described in Sections A.2, Criteria for distribution, and B.2 through B.9, must contain the full amount of the institution's modified total costs or other appropriate units of measurement used to make the computations. In addition, the final rate distribution base (as defined in subsection 2) for each major function (organized research, instruction, etc., as described in Section A.1, Major functions of an institution) must contain all the programs or activities which utilize the indirect (F&A) costs allocated to that major function. At the time an indirect (F&A) cost proposal is submitted to a cognizant agency for indirect costs, each institution must describe the process it uses to ensure that Federal funds are not used to subsidize industry and foreign government funded programs.

b. In some instances a single rate basis for use across the board on all work within a major function at an institution may not be appropriate. A single rate for research, for example, might not take into account those different environmental factors and other conditions which may affect substantially the indirect (F&A) costs applicable to a particular segment of research at the institution. A particular segment of research may be

that performed under a single sponsored agreement or it may consist of research under a group of Federal awards performed in a common environment. The environmental factors are not limited to the physical location of the work. Other important factors are the level of the administrative support required, the nature of the facilities or other resources employed, the scientific disciplines or technical skills involved, the organizational arrangements used, or any combination thereof. If a particular segment of a sponsored agreement is performed within an environment which appears to generate a significantly different level of indirect (F&A) costs, provisions should be made for a separate indirect (F&A) cost pool applicable to such work. The separate indirect (F&A) cost pool should be developed during the regular course of the rate determination process and the separate indirect (F&A) cost rate resulting therefrom should be utilized; provided it is determined that (1) such indirect (F&A) cost rate differs significantly from that which would have been obtained under subsection a, and (2) the volume of work to which such rate would apply is material in relation to other Federal awards at the institution.

2. The Distribution Basis

Indirect (F&A) costs must be distributed to applicable Federal awards and other benefitting activities within each major function (see section A.1. Major functions of an institution) on the basis of modified total direct costs (MTDC), consisting of all salaries and wages, fringe benefits, materials and supplies, services, travel, and up to the first \$25,000 of each subaward (regardless of the period covered by the subaward). MTDC is defined in §200.68 Modified Total Direct Cost (MTDC). For this purpose, an indirect (F&A) cost rate should be determined for each of the separate indirect (F&A) cost pools developed pursuant to subsection 1. The rate in each case should be stated as the percentage which the amount of the particular indirect (F&A) cost pool is of the modified total direct costs identified with such pool.

3. Negotiated Lump Sum for Indirect (F&A) Costs

A negotiated fixed amount in lieu of indirect (F&A) costs may be appropriate for self-contained, off-campus, or primarily subcontracted activities where the benefits derived from an institution's indirect (F&A) services cannot be readily determined. Such negotiated indirect (F&A) costs will be treated as an offset before allocation to instruction, organized research, other sponsored activities, and other institutional activities. The base on which such remaining expenses are allocated should be appropriately adjusted.

4. Predetermined Rates for Indirect (F&A) Costs

Public Law 87-638 (76 Stat. 437) as amended (41 U.S.C. 4708) authorizes the use of predetermined rates in determining the "indirect costs" (indirect (F&A) costs) applicable under research agreements with educational institutions. The stated objectives of the law are to simplify the administration of cost-type research and development contracts (including grants) with educational institutions, to facilitate the preparation of their budgets, and to permit more expeditious closeout of such contracts when the work is completed. In view of the potential advantages offered by this procedure, negotiation of predetermined rates for indirect (F&A) costs for a period of two to four years should be the norm in those situations where the cost experience and other pertinent facts available are deemed sufficient to enable the parties involved to reach an informed judgment as to the probable level of indirect (F&A) costs during the ensuing accounting periods.

5. Negotiated Fixed Rates and Carry-Forward Provisions

When a fixed rate is negotiated in advance for a fiscal year (or other time period), the over- or under-recovery for that year may be included as an adjustment to the indirect (F&A) cost for the next rate negotiation. When the rate is negotiated before the carry-forward adjustment is determined, the carry-forward amount may be applied to the next subsequent rate negotiation. When such adjustments are to be made, each fixed rate negotiated in advance for a given period will be computed by applying the expected indirect (F&A) costs allocable to Federal awards for the forecast period plus or minus the carry-forward adjustment (over- or under-recovery) from the prior period, to the forecast distribution base. Unrecovered amounts under lump-sum agreements or cost-sharing provisions of prior years must not be carried forward for consideration in the new rate negotiation. There must, however, be an advance understanding in each case between the institution and the cognizant agency for indirect costs as to whether these differences will be considered in the rate negotiation rather than making the determination after the differences are known. Further, institutions electing to use this carry-forward provision may not subsequently change without prior approval of the cognizant agency for indirect costs. In the event that an institution returns to a post-determined rate, any over- or under-recovery during the period in which negotiated fixed rates and carry-forward provisions were followed will be included in the subsequent post-determined rates. Where multiple rates are used, the same procedure will be applicable for determining each rate.

6. Provisional and Final Rates for Indirect (F&A) Costs

Where the cognizant agency for indirect costs determines that cost experience and other pertinent facts do not justify the use of predetermined rates, or a fixed rate with a carry-forward, or if the parties cannot agree on an equitable rate, a provisional rate must be established. To prevent substantial overpayment or underpayment, the provisional rate may be adjusted by the cognizant agency for indirect costs during the institution's fiscal year. Predetermined or fixed rates may replace provisional rates at any time prior to the close of the institution's fiscal year. If a provisional rate is not replaced by a predetermined or fixed rate prior to the end of the institution's fiscal year, a final rate will be established and upward or downward adjustments will be made based on the actual allowable costs incurred for the period involved.

7. Fixed Rates for the Life of the Sponsored Agreement

Except as provided in paragraph (c)(1) of §200.414 Indirect (F&A) costs, Federal agencies must use the negotiated rates, must paragraph (b)(1) for indirect (F&A) costs in effect at the time of the initial award throughout the life of the Federal award. Award levels for Federal awards may not be adjusted in future years as a result of changes in negotiated rates. "Negotiated rates" per the rate agreement include final, fixed, and predetermined rates and exclude provisional rates. "Life" for the purpose of this subsection means each competitive segment of a project. A competitive segment is a period of years approved by the Federal awarding agency at the time of the Federal award. If negotiated rate agreements do not extend through the life of the Federal award at the time of the initial award, then the negotiated rate for the last year of the Federal award must be extended through the end of the life of the Federal award.

b. Except as provided in §200.414 Indirect (F&A) costs, when an educational institution does not have a negotiated rate with the Federal Government at the time of an award (because the educational institution is a new recipient or the parties cannot reach agreement on a rate), the provisional rate used at the time of the award must be adjusted once a rate is negotiated and approved by the cognizant agency for indirect costs.

8. Limitation on Reimbursement of Administrative Costs

a. Notwithstanding the provisions of subsection C.1.a, the administrative costs charged to Federal awards awarded or amended (including continuation and renewal awards) with effective dates beginning on or after the start of the institution's first fiscal year which begins on or after October 1, 1991, must be limited to 26% of modified total direct costs (as defined in subsection 2) for the total of General Administration and General Expenses, Departmental Administration, Sponsored Projects Administration, and Student Administration and Services (including their allocable share of depreciation, interest costs, operation and maintenance expenses, and fringe benefits costs, as provided by Section B,

Identification and assignment of indirect (F&A) costs, and all other types of expenditures not listed specifically under one of the subcategories of facilities in Section B.

b. Institutions should not change their accounting or cost allocation methods if the effect is to change the charging of a particular type of cost from F&A to direct, or to reclassify costs, or increase allocations from the administrative pools identified in paragraph B.1 of this Appendix to the other F&A cost pools or fringe benefits. Cognizant agencies for indirect cost are authorized to allow changes where an institution's charging practices are at variance with acceptable practices followed by a substantial majority of other institutions.

9. Alternative Method for Administrative Costs

a. Notwithstanding the provisions of subsection C.1.a, an institution may elect to claim a fixed allowance for the "Administration" portion of indirect (F&A) costs. The allowance could be either 24% of modified total direct costs or a percentage equal to 95% of the most recently negotiated fixed or predetermined rate for the cost pools included under "Administration" as defined in Section B.1, whichever is less. Under this alternative, no cost proposal need be prepared for the "Administration" portion of the indirect (F&A) cost rate nor is further identification or documentation of these costs required (see subsection c). Where a negotiated indirect (F&A) cost agreement includes this alternative, an institution must make no further charges for the expenditure categories described in Section B.5, General administration and general expenses, Section B.6, Departmental administration expenses, Section B.7, Sponsored projects administration, and Section B.9, Student administration and services.

b. In negotiations of rates for subsequent periods, an institution that has elected the option of subsection a may continue to exercise it at the same rate without further identification or documentation of costs.

c. If an institution elects to accept a threshold rate as defined in subsection a of this section, it is not required to perform a detailed analysis of its administrative costs. However, in order to compute the facilities components of its indirect (F&A) cost rate, the institution must reconcile its indirect (F&A) cost proposal to its financial statements and make appropriate adjustments and reclassifications to identify the costs of each major function as defined in Section A.1, as well as to identify and allocate the facilities components. Administrative costs that are not identified as such by the institution's accounting system (such as those incurred in academic departments) will be classified as instructional costs for purposes of reconciling indirect (F&A) cost proposals to financial statements and allocating facilities costs.

10. Individual Rate Components

In order to provide mutually agreed-upon information for management purposes, each indirect (F&A) cost rate negotiation or determination must include development of a rate for each indirect (F&A) cost pool as well as the overall indirect (F&A) cost rate.

11. Negotiation and Approval of Indirect (F&A) Rate

a. Cognizant agency for indirect costs is defined in Subpart A—Acronyms and Definitions.

(1) Cost negotiation cognizance is assigned to the Department of Health and Human Services (HHS) or the Department of Defense's Office of Naval Research (DOD), normally depending on which of the two agencies (HHS or DOD) provides more funds to the educational institution for the most recent three years. Information on funding must be derived from relevant data gathered by the National Science Foundation. In cases where neither HHS nor DOD provides Federal funding to an educational institution, the cognizant agency for indirect costs assignment must default to HHS. Notwithstanding the method for cognizance determination described in this section, other arrangements for cognizance of a particular educational institution may also be based in part on the types of research performed at the educational institution and must be decided based on mutual agreement between HHS and DOD. Where a non-Federal entity only receives funds as a subrecipient, §200.331 Requirements for pass-through entities.

(2) After cognizance is established, it must continue for a five-year period.

b. Acceptance of rates. See §200.414 Indirect (F&A) costs.

c. Correcting deficiencies. The cognizant agency for indirect costs must negotiate changes needed to correct systems deficiencies relating to accountability for Federal awards. Cognizant agencies for indirect costs must address the concerns of other affected agencies, as appropriate, and must negotiate special rates for Federal agencies that are required to limit recovery of indirect costs by statute.

d. Resolving questioned costs. The cognizant agency for indirect costs must conduct any necessary negotiations with an educational institution regarding amounts questioned by audit that are due the Federal Government related to costs covered by a negotiated agreement.

e. Reimbursement. Reimbursement to cognizant agencies for indirect costs for work performed under this Part may be made by reimbursement billing under the Economy Act, 31 U.S.C. 1535.

f. Procedure for establishing facilities and administrative rates must be established by one of the following methods:

(1) Formal negotiation. The cognizant agency for indirect costs is responsible for negotiating and approving rates for an educational institution on behalf of all Federal agencies. Federal awarding agencies that do not have cognizance for indirect costs, must notify the cognizant agency for indirect costs of specific concerns (i.e., a need to establish special cost rates) which could affect the negotiation process. The cognizant agency for indirect costs must address the concerns of all interested agencies, as appropriate. A pre-negotiation conference may be scheduled among all interested agencies, if necessary. The cognizant agency for indirect costs must then arrange a negotiation conference with the educational institution.

(2) Other than formal negotiation. The cognizant agency for indirect costs and educational institution may reach an agreement on rates without a formal negotiation conference; for example, through correspondence or use of the simplified method described in this section D of this Appendix.

g. Formalizing determinations and agreements. The cognizant agency for indirect costs must formalize all determinations or agreements reached with an educational institution and provide copies to other agencies having an interest. Determinations should include a description of any adjustments, the actual amount, both dollar and percentage adjusted, and the reason for making adjustments.

h. Disputes and disagreements. Where the cognizant agency for indirect costs is unable to reach agreement with an educational institution with regard to rates or audit resolution, the appeal system of the cognizant agency for indirect costs must be followed for resolution of the disagreement.

12. Standard Format for Submission

For facilities and administrative (indirect (F&A)) rate proposals, educational institutions must use the standard format, shown in section E of this appendix, to submit their indirect (F&A) rate proposal to the cognizant agency for indirect costs. The cognizant agency for indirect costs may, on an institution-by-institution basis, grant exceptions from all or portions of Part II of the standard format requirement. This requirement does not apply to educational institutions that use the simplified method for calculating indirect (F&A) rates, as described in Section D of this Appendix.

As provided in section C.10 of this appendix, each F&A cost rate negotiation or determination must include development of a rate for each F&A cost pool as well as the overall F&A rate.

D. SIMPLIFIED METHOD FOR SMALL INSTITUTIONS

1. General

a. Where the total direct cost of work covered by this Part at an institution does not exceed \$10 million in a fiscal year, the simplified procedure described in subsections 2 or 3 may be used in determining allowable indirect (F&A) costs. Under this simplified procedure, the institution's most recent annual financial report and immediately available supporting information must be utilized as a basis for determining the indirect (F&A) cost rate applicable to all Federal awards. The institution may use either the salaries and wages (see subsection 2) or modified total direct costs (see subsection 3) as the distribution basis.

b. The simplified procedure should not be used where it produces results which appear inequitable to the Federal Government or the institution. In any such case, indirect (F&A) costs should be determined through use of the regular procedure.

2. Simplified Procedure—Salaries and Wages Base

a. Establish the total amount of salaries and wages paid to all employees of the institution.

b. Establish an indirect (F&A) cost pool consisting of the expenditures (exclusive of capital items and other costs specifically identified as unallowable) which customarily are classified under the following titles or their equivalents:

(1) General administration and general expenses (exclusive of costs of student administration and services, student activities, student aid, and scholarships).

(2) Operation and maintenance of physical plant and depreciation (after appropriate adjustment for costs applicable to other institutional activities).

(3) Library.

(4) Department administration expenses, which will be computed as 20 percent of the salaries and expenses of deans and heads of departments.

In those cases where expenditures classified under subsection (1) have previously been allocated to other institutional activities, they may be included in the indirect (F&A) cost pool. The total amount of salaries and wages included in the indirect (F&A) cost pool must be separately identified.

c. Establish a salary and wage distribution base, determined by deducting from the total of salaries and wages as established in subsection a from the amount of salaries and wages included under subsection b.

d. Establish the indirect (F&A) cost rate, determined by dividing the amount in the indirect (F&A) cost pool, subsection b, by the amount of the distribution base, subsection c.

e. Apply the indirect (F&A) cost rate to direct salaries and wages for individual agreements to determine the amount of indirect (F&A) costs allocable to such agreements.

3. Simplified Procedure—Modified Total Direct Cost Base

a. Establish the total costs incurred by the institution for the base period.

b. Establish an indirect (F&A) cost pool consisting of the expenditures (exclusive of capital items and other costs specifically identified as unallowable) which customarily are classified under the following titles or their equivalents:

(1) General administration and general expenses (exclusive of costs of student administration and services, student activities, student aid, and scholarships).

(2) Operation and maintenance of physical plant and depreciation (after appropriate adjustment for costs applicable to other institutional activities).

(3) Library.

(4) Department administration expenses, which will be computed as 20 percent of the salaries and expenses of deans and heads of departments. In those cases where expenditures classified under subsection (1) have previously been allocated to other institutional activities, they may be included in the indirect (F&A) cost pool. The modified total direct costs amount included in the indirect (F&A) cost pool must be separately identified.

c. Establish a modified total direct cost distribution base, as defined in Section C.2, The distribution basis, that consists of all institution's direct functions.

d. Establish the indirect (F&A) cost rate, determined by dividing the amount in the indirect (F&A) cost pool, subsection b, by the amount of the distribution base, subsection c.

e. Apply the indirect (F&A) cost rate to the modified total direct costs for individual agreements to determine the amount of indirect (F&A) costs allocable to such agreements.

E. DOCUMENTATION REQUIREMENTS

The standard format for documentation requirements for indirect (indirect (F&A)) rate proposals for claiming costs under the regular method is available on the OMB Web site here: http://www.whitehouse.gov/omb/grants_forms.

F. CERTIFICATION

1. Certification of Charges

To assure that expenditures for Federal awards are proper and in accordance with the agreement documents and approved project budgets, the annual and/or final fiscal reports or vouchers requesting payment under the agreements will include a certification, signed by an authorized official of the university, which reads "By signing this report, I certify to the best of my knowledge and belief that the report is true, complete, and accurate, and the expenditures, disbursements and cash receipts are for the purposes and intent set forth in the award documents. I am aware that any false, fictitious, or fraudulent information, or the omission of any material fact, may subject me to criminal, civil or administrative penalties for fraud, false statements, false claims or otherwise. (U.S. Code, Title 18, Section 1001 and Title 31, Sections 3729-3733 and 3801-3812)".

2. Certification of Indirect (F&A) Costs

a. *Policy.* Cognizant agencies must not accept a proposed indirect cost rate unless such costs have been certified by the educational institution using the Certificate of indirect (F&A) Costs set forth in subsection F.2.c

b. The certificate must be signed on behalf of the institution by the chief financial officer or an individual designated by an individual at a level no lower than vice president or chief financial officer.

An indirect (F&A) cost rate is not binding upon the Federal Government if the most recent required proposal from the institution has not been certified. Where it is necessary to establish indirect (F&A) cost rates, and the institution has not submitted a certified proposal for establishing such rates in accordance with the requirements of this section, the Federal Government must unilaterally establish such rates. Such rates may be based upon audited historical data or such other data that have been furnished to the cognizant agency for indirect costs and for which it can be demonstrated that all unallowable costs have been excluded. When indirect (F&A) cost rates are unilaterally established by the Federal Government because of failure of the institution to submit a certified proposal for establishing such rates in accordance with this section, the rates established will be set at a level low enough to ensure that potentially unallowable costs will not be reimbursed.

c. *Certificate.* The certificate required by this section must be in the following form:

CERTIFICATE OF INDIRECT (F&A) COSTS

This is to certify that to the best of my knowledge and belief:

(1) I have reviewed the indirect (F&A) cost proposal submitted herewith;

(2) All costs included in this proposal [identify date] to establish billing or final indirect (F&A) costs rate for [identify period covered by rate] are allowable in accordance with the requirements of the Federal agreement(s) to which they apply and with the cost principles applicable to those agreements.

(3) This proposal does not include any costs which are unallowable under applicable cost principles such as (without limitation): public relations costs, contributions and donations, entertainment costs, fines and penalties, lobbying costs, and defense of fraud proceedings; and

(4) All costs included in this proposal are properly allocable to Federal agreements on the basis of a beneficial or causal relationship between the expenses incurred and the agreements to which they are allocated in accordance with applicable requirements.

I declare that the foregoing is true and correct.

Institution of Higher Education:

Signature: _____

Name of Official: _____

Title: _____

Date of Execution:

[78 FR 78608, Dec. 26, 2013, as amended at 79 FR 75888, Dec. 19, 2014]

[↑ Back to Top](#)

Appendix IV to Part 200—Indirect (F&A) Costs Identification and Assignment, and Rate Determination for Nonprofit Organizations

A. GENERAL

1. Indirect costs are those that have been incurred for common or joint objectives and cannot be readily identified with a particular final cost objective. Direct cost of minor amounts may be treated as indirect costs under the conditions described in §200.413 Direct costs paragraph (d) of this Part. After direct costs have been determined and assigned directly to awards or other work as appropriate, indirect costs are those remaining to be allocated to benefitting cost objectives. A cost may not be allocated to a Federal award as an indirect cost if any other cost incurred for the same purpose, in like circumstances, has been assigned to a Federal award as a direct cost.

"Major nonprofit organizations" are defined in §200.414 Indirect (F&A) costs. See indirect cost rate reporting requirements in sections B.2.e and B.3.g of this Appendix.

B. ALLOCATION OF INDIRECT COSTS AND DETERMINATION OF INDIRECT COST RATES

1. General

a. If a nonprofit organization has only one major function, or where all its major functions benefit from its indirect costs to approximately the same degree, the allocation of indirect costs and the computation of an indirect cost rate may be accomplished through simplified allocation procedures, as described in section B.2 of this Appendix.

b. If an organization has several major functions which benefit from its indirect costs in varying degrees, allocation of indirect costs may require the accumulation of such costs into separate cost groupings which then are allocated individually to benefitting functions by means of a base which best measures the relative degree of benefit. The indirect costs allocated to each function are then distributed to individual Federal awards and other activities included in that function by means of an indirect cost rate(s).

c. The determination of what constitutes an organization's major functions will depend on its purpose in being; the types of services it renders to the public, its clients, and its members; and the amount of effort it devotes to such activities as fundraising, public information and membership activities.

d. Specific methods for allocating indirect costs and computing indirect cost rates along with the conditions under which each method should be used are described in section B.2 through B.5 of this Appendix.

e. The base period for the allocation of indirect costs is the period in which such costs are incurred and accumulated for allocation to work performed in that period. The base period normally should coincide with the organization's fiscal year but, in any event, must be so selected as to avoid inequities in the allocation of the costs.

2. Simplified Allocation Method

a. Where an organization's major functions benefit from its indirect costs to approximately the same degree, the allocation of indirect costs may be accomplished by (i) separating the organization's total costs for the base period as either direct or indirect, and (ii) dividing the total allowable indirect costs (net of applicable credits) by an equitable distribution base. The result of this process is an indirect cost rate which is used to distribute indirect costs to individual Federal awards. The rate should be expressed as the percentage which the total amount of allowable indirect costs bears to the base selected. This method should also be used where an organization has only one major function encompassing a number of individual projects or activities, and may be used where the level of Federal awards to an organization is relatively small.

b. Both the direct costs and the indirect costs must exclude capital expenditures and unallowable costs. However, unallowable costs which represent activities must be included in the direct costs under the conditions described in §200.413 Direct costs, paragraph (e) of this Part.

c. The distribution base may be total direct costs (excluding capital expenditures and other distorting items, such as subawards for \$25,000 or more), direct salaries and wages, or other base which results in an equitable distribution. The distribution base must exclude participant support costs as defined in §200.75 Participant support costs.

d. Except where a special rate(s) is required in accordance with section B.5 of this Appendix, the indirect cost rate developed under the above principles is applicable to all Federal awards of the organization. If a special rate(s) is required, appropriate modifications must be made in order to develop the special rate(s).

e. For an organization that receives more than \$10 million in Federal funding of direct costs in a fiscal year, a breakout of the indirect cost component into two broad categories, Facilities and Administration as defined in section A.3 of this Appendix, is required. The rate in each case must be stated as the percentage which the amount of the particular indirect cost category (i.e., Facilities or Administration) is of the distribution base identified with that category.

3. Multiple Allocation Base Method

a. General. Where an organization's indirect costs benefit its major functions in varying degrees, indirect costs must be accumulated into separate cost groupings, as described in subparagraph b. Each grouping must then be allocated individually to benefitting functions by means of a base which best measures the relative benefits. The default allocation bases by cost pool are described in section B.3.c of this Appendix.

b. Identification of indirect costs. Cost groupings must be established so as to permit the allocation of each grouping on the basis of benefits provided to the major functions. Each grouping must constitute a pool of expenses that are of like character in terms of functions they benefit and in terms of the allocation base which best measures the relative benefits provided to each function. The groupings are classified within the two broad categories: "Facilities" and "Administration," as described in section A.3 of this Appendix. The indirect cost pools are defined as follows:

(1) Depreciation. The expenses under this heading are the portion of the costs of the organization's buildings, capital improvements to land and buildings, and equipment which are computed in accordance with §200.436 Depreciation.

(2) Interest. Interest on debt associated with certain buildings, equipment and capital improvements are computed in accordance with §200.449 Interest.

(3) Operation and maintenance expenses. The expenses under this heading are those that have been incurred for the administration, operation, maintenance, preservation, and protection of the organization's physical plant. They include expenses normally incurred for such items as: janitorial and utility services; repairs and ordinary or normal alterations of buildings, furniture and equipment; care of grounds; maintenance and operation of buildings and other plant facilities; security; earthquake and disaster preparedness; environmental safety; hazardous waste disposal; property, liability and other insurance relating to property; space and capital leasing; facility planning and management; and central receiving. The operation and maintenance expenses category must also include its allocable share of fringe benefit costs, depreciation, and interest costs.

(4) General administration and general expenses. The expenses under this heading are those that have been incurred for the overall general executive and administrative offices of the organization and other expenses of a general nature which do not relate solely to any major function of the organization. This category must also include its allocable share of fringe benefit costs, operation and maintenance expense, depreciation, and interest costs. Examples of this category include central offices, such as the director's office, the office of finance, business services, budget and planning, personnel, safety and risk management, general counsel, management information systems, and library costs.

In developing this cost pool, special care should be exercised to ensure that costs incurred for the same purpose in like circumstances are treated consistently as either direct or indirect costs. For example, salaries of technical staff, project supplies, project publication, telephone toll charges, computer costs, travel costs, and specialized services costs must be treated as direct costs wherever identifiable to a particular program. The salaries and wages of administrative and pooled clerical staff should normally be treated as indirect costs. Direct charging of these costs may be appropriate as described in §200.413 Direct Costs. Items such as office supplies, postage, local telephone costs, periodicals and memberships should normally be treated as indirect costs.

c. Allocation bases. Actual conditions must be taken into account in selecting the base to be used in allocating the expenses in each grouping to benefitting functions. The essential consideration in selecting a method or a base is that it is the one best suited for assigning the pool of costs to cost objectives in accordance with benefits derived; a traceable cause and effect relationship; or logic and reason, where neither the cause nor the effect of the relationship is determinable. When an allocation can be made by assignment of a cost grouping directly to the function benefitted, the allocation must be made in that manner. When the expenses in a cost grouping are more general in nature, the allocation must be made through the use of a selected base which produces results that are equitable to both the Federal Government and the organization. The distribution must be made in accordance with the bases described herein unless it can be demonstrated that the use of a different base would result in a more equitable allocation of the costs, or that a more readily available base would not increase the costs charged to Federal awards. The results of special cost studies (such as an engineering utility study) must not be used to determine and allocate the indirect costs to Federal awards.

(1) Depreciation. Depreciation expenses must be allocated in the following manner:

(a) Depreciation on buildings used exclusively in the conduct of a single function, and on capital improvements and equipment used in such buildings, must be assigned to that function.

(b) Depreciation on buildings used for more than one function, and on capital improvements and equipment used in such buildings, must be allocated to the individual functions performed in each building on the basis of usable square feet of space, excluding common areas, such as hallways, stairwells, and restrooms.

(c) Depreciation on buildings, capital improvements and equipment related space (e.g., individual rooms, and laboratories) used jointly by more than one function (as determined by the users of the space) must be treated as follows. The cost of each jointly used unit of space must be allocated to the benefitting functions on the basis of:

(i) the employees and other users on a full-time equivalent (FTE) basis or salaries and wages of those individual functions benefitting from the use of that space; or

(ii) organization-wide employee FTEs or salaries and wages applicable to the benefitting functions of the organization.

(d) Depreciation on certain capital improvements to land, such as paved parking areas, fences, sidewalks, and the like, not included in the cost of buildings, must be allocated to user categories on a FTE basis and distributed to major functions in proportion to the salaries and wages of all employees applicable to the functions.

(2) Interest. Interest costs must be allocated in the same manner as the depreciation on the buildings, equipment and capital equipment to which the interest relates.

(3) Operation and maintenance expenses. Operation and maintenance expenses must be allocated in the same manner as the depreciation.

(4) General administration and general expenses. General administration and general expenses must be allocated to benefitting functions based on modified total costs (MTC). The MTC is the modified total direct costs (MTDC), as described in Subpart A—Acronyms and Definitions of Part 200, plus the allocated indirect cost proportion. The expenses included in this category could be grouped first according to major functions of the organization to which they render services or provide benefits. The aggregate expenses of each group must then be allocated to benefitting functions based on MTC.

d. Order of distribution.

(1) Indirect cost categories consisting of depreciation, interest, operation and maintenance, and general administration and general expenses must be allocated in that order to the remaining indirect cost categories as well as to the major functions of the organization. Other cost categories should be allocated in the order determined to be most appropriate by the organization. This order of allocation does not apply if cross allocation of costs is made as provided in section B.3.d.2 of this Appendix.

(2) Normally, an indirect cost category will be considered closed once it has been allocated to other cost objectives, and costs must not be subsequently allocated to it. However, a cross allocation of costs between two or more indirect costs categories could be used if such allocation will result in a more equitable allocation of costs. If a cross allocation is used, an appropriate modification to the composition of the indirect cost categories is required.

e. Application of indirect cost rate or rates. Except where a special indirect cost rate(s) is required in accordance with section B.5 of this Appendix, the separate groupings of indirect costs allocated to each major function must be aggregated and treated as a common pool for that function. The costs in the common pool must then be distributed to individual Federal awards included in that function by use of a single indirect cost rate.

f. Distribution basis. Indirect costs must be distributed to applicable Federal awards and other benefitting activities within each major function on the basis of MTDC (see definition in §200.68 Modified Total Direct Cost (MTDC) of Part 200.

g. Individual Rate Components. An indirect cost rate must be determined for each separate indirect cost pool developed. The rate in each case must be stated as the percentage which the amount of the particular indirect cost pool is of the distribution base identified with that pool. Each indirect cost rate negotiation or determination agreement must include development of the rate for each indirect cost pool as well as the overall indirect cost rate. The indirect cost pools must be classified within two broad categories: "Facilities" and "Administration," as described in section A.3 of this Appendix.

4. Direct Allocation Method

a. Some nonprofit organizations treat all costs as direct costs except general administration and general expenses. These organizations generally separate their costs into three basic categories: (i) General administration and general expenses, (ii) fundraising, and (iii) other direct functions (including projects performed under Federal awards). Joint costs, such as depreciation, rental costs, operation and maintenance of facilities, telephone expenses, and the like are prorated individually as direct costs to each category and to each Federal award or other activity using a base most appropriate to the particular cost being prorated.

b. This method is acceptable, provided each joint cost is prorated using a base which accurately measures the benefits provided to each Federal award or other activity. The bases must be established in accordance with reasonable criteria, and be supported by current data. This

method is compatible with the Standards of Accounting and Financial Reporting for Voluntary Health and Welfare Organizations issued jointly by the National Health Council, Inc., the National Assembly of Voluntary Health and Social Welfare Organizations, and the United Way of America.

c. Under this method, indirect costs consist exclusively of general administration and general expenses. In all other respects, the organization's indirect cost rates must be computed in the same manner as that described in section B.2 Simplified allocation method of this Appendix.

5. Special Indirect Cost Rates

In some instances, a single indirect cost rate for all activities of an organization or for each major function of the organization may not be appropriate, since it would not take into account those different factors which may substantially affect the indirect costs applicable to a particular segment of work. For this purpose, a particular segment of work may be that performed under a single Federal award or it may consist of work under a group of Federal awards performed in a common environment. These factors may include the physical location of the work, the level of administrative support required, the nature of the facilities or other resources employed, the scientific disciplines or technical skills involved, the organizational arrangements used, or any combination thereof. When a particular segment of work is performed in an environment which appears to generate a significantly different level of indirect costs, provisions should be made for a separate indirect cost pool applicable to such work. The separate indirect cost pool should be developed during the course of the regular allocation process, and the separate indirect cost rate resulting therefrom should be used, provided it is determined that (i) the rate differs significantly from that which would have been obtained under sections B.2, B.3, and B.4 of this Appendix, and (ii) the volume of work to which the rate would apply is material.

C. NEGOTIATION AND APPROVAL OF INDIRECT COST RATES

1. Definitions

As used in this section, the following terms have the meanings set forth in this section:

a. *Cognizant agency for indirect costs* means the Federal agency responsible for negotiating and approving indirect cost rates for a nonprofit organization on behalf of all Federal agencies.

b. *Predetermined rate* means an indirect cost rate, applicable to a specified current or future period, usually the organization's fiscal year. The rate is based on an estimate of the costs to be incurred during the period. A predetermined rate is not subject to adjustment.

c. *Fixed rate* means an indirect cost rate which has the same characteristics as a predetermined rate, except that the difference between the estimated costs and the actual costs of the period covered by the rate is carried forward as an adjustment to the rate computation of a subsequent period.

d. *Final rate* means an indirect cost rate applicable to a specified past period which is based on the actual costs of the period. A final rate is not subject to adjustment.

e. *Provisional rate or billing rate* means a temporary indirect cost rate applicable to a specified period which is used for funding, interim reimbursement, and reporting indirect costs on Federal awards pending the establishment of a final rate for the period.

f. *Indirect cost proposal* means the documentation prepared by an organization to substantiate its claim for the reimbursement of indirect costs. This proposal provides the basis for the review and negotiation leading to the establishment of an organization's indirect cost rate.

g. *Cost objective* means a function, organizational subdivision, contract, Federal award, or other work unit for which cost data are desired and for which provision is made to accumulate and measure the cost of processes, projects, jobs and capitalized projects.

2. Negotiation and Approval of Rates

a. Unless different arrangements are agreed to by the Federal agencies concerned, the Federal agency with the largest dollar value of Federal awards with an organization will be designated as the cognizant agency for indirect costs for the negotiation and approval of the indirect cost rates and, where necessary, other rates such as fringe benefit and computer charge-out rates. Once an agency is assigned cognizance for a particular nonprofit organization, the assignment will not be changed unless there is a shift in the dollar volume of the Federal awards to the organization for at least three years. All concerned Federal agencies must be given the opportunity to participate in the negotiation process but, after a rate has been agreed upon, it will be accepted by all Federal agencies. When a Federal agency has reason to believe that special operating factors affecting its Federal awards necessitate special indirect cost rates in accordance with section B.5 of this Appendix, it will, prior to the time the rates are negotiated, notify the cognizant agency for indirect costs. (See also §200.414 Indirect (F&A) costs of Part 200.) Where a non-Federal entity only receives funds as a subrecipient, see the requirements of §200.331 Requirements for pass-through entities.

b. Except as otherwise provided in §200.414 Indirect (F&A) costs paragraph (e) of this Part, a nonprofit organization which has not previously established an indirect cost rate with a Federal agency must submit its initial indirect cost proposal immediately after the organization is advised that a Federal award will be made and, in no event, later than three months after the effective date of the Federal award.

c. Unless approved by the cognizant agency for indirect costs in accordance with §200.414 Indirect (F&A) costs paragraph (f) of this Part, organizations that have previously established indirect cost rates must submit a new indirect cost proposal to the cognizant agency for indirect costs within six months after the close of each fiscal year.

d. A predetermined rate may be negotiated for use on Federal awards where there is reasonable assurance, based on past experience and reliable projection of the organization's costs, that the rate is not likely to exceed a rate based on the organization's actual costs.

e. Fixed rates may be negotiated where predetermined rates are not considered appropriate. A fixed rate, however, must not be negotiated if (i) all or a substantial portion of the organization's Federal awards are expected to expire before the carry-forward adjustment can be made; (ii) the mix of Federal and non-Federal work at the organization is too erratic to permit an equitable carry-forward adjustment; or (iii) the organization's operations fluctuate significantly from year to year.

f. Provisional and final rates must be negotiated where neither predetermined nor fixed rates are appropriate. Predetermined or fixed rates may replace provisional rates at any time prior to the close of the organization's fiscal year. If that event does not occur, a final rate will be established and upward or downward adjustments will be made based on the actual allowable costs incurred for the period involved.

g. The results of each negotiation must be formalized in a written agreement between the cognizant agency for indirect costs and the nonprofit organization. The cognizant agency for indirect costs must make available copies of the agreement to all concerned Federal agencies.

h. If a dispute arises in a negotiation of an indirect cost rate between the cognizant agency for indirect costs and the nonprofit organization, the dispute must be resolved in accordance with the appeals procedures of the cognizant agency for indirect costs.

i. To the extent that problems are encountered among the Federal agencies in connection with the negotiation and approval process, OMB will lend assistance as required to resolve such problems in a timely manner.

D. Certification of Indirect (F&A) Costs

(1) Required Certification. No proposal to establish indirect (F&A) cost rates must be acceptable unless such costs have been certified by the non-profit organization using the Certificate of Indirect (F&A) Costs set forth in section j. of this appendix. The certificate must be signed on behalf of the organization by an individual at a level no lower than vice president or chief financial officer for the organization.

(2) Each indirect cost rate proposal must be accompanied by a certification in the following form:

Certificate of Indirect (F&A) Costs

This is to certify that to the best of my knowledge and belief:

(1) I have reviewed the indirect (F&A) cost proposal submitted herewith;

(2) All costs included in this proposal [identify date] to establish billing or final indirect (F&A) costs rate for [identify period covered by rate] are allowable in accordance with the requirements of the Federal awards to which they apply and with Subpart E—Cost Principles of Part 200.

(3) This proposal does not include any costs which are unallowable under Subpart E—Cost Principles of Part 200 such as (without limitation): public relations costs, contributions and donations, entertainment costs, fines and penalties, lobbying costs, and defense of fraud proceedings; and

(4) All costs included in this proposal are properly allocable to Federal awards on the basis of a beneficial or causal relationship between the expenses incurred and the Federal awards to which they are allocated in accordance with applicable requirements.

I declare that the foregoing is true and correct.

Nonprofit Organization:

Signature:

Name of Official:

Title:

Date of Execution:

[↑ Back to Top](#)

Appendix V to Part 200—State/Local Governmentwide Central Service Cost Allocation Plans

A. GENERAL

1. Most governmental units provide certain services, such as motor pools, computer centers, purchasing, accounting, etc., to operating agencies on a centralized basis. Since federally-supported awards are performed within the individual operating agencies, there needs to be a process whereby these central service costs can be identified and assigned to benefitted activities on a reasonable and consistent basis. The central service cost allocation plan provides that process. All costs and other data used to distribute the costs included in the plan should be supported by formal accounting and other records that will support the propriety of the costs assigned to Federal awards.

2. Guidelines and illustrations of central service cost allocation plans are provided in a brochure published by the Department of Health and Human Services entitled "A Guide for State, Local and Indian Tribal Governments: Cost Principles and Procedures for Developing Cost Allocation Plans and Indirect Cost Rates for Agreements with the Federal Government." A copy of this brochure may be obtained from the HHS Cost Allocation Services or at their Web site at <https://rates.psc.gov>.

B. DEFINITIONS

1. *Agency or operating agency* means an organizational unit or sub-division within a governmental unit that is responsible for the performance or administration of Federal awards or activities of the governmental unit.

2. *Allocated central services* means central services that benefit operating agencies but are not billed to the agencies on a fee-for-service or similar basis. These costs are allocated to benefitted agencies on some reasonable basis. Examples of such services might include general accounting, personnel administration, purchasing, etc.

3. *Billed central services* means central services that are billed to benefitted agencies or programs on an individual fee-for-service or similar basis. Typical examples of billed central services include computer services, transportation services, insurance, and fringe benefits.

4. *Cognizant agency for indirect costs* is defined in §200.19 Cognizant agency for indirect costs of this Part. The determination of cognizant agency for indirect costs for states and local governments is described in section F.1, Negotiation and Approval of Central Service Plans.

5. *Major local government* means local government that receives more than \$100 million in direct Federal awards subject to this Part.

C. SCOPE OF THE CENTRAL SERVICE COST ALLOCATION PLANS

The central service cost allocation plan will include all central service costs that will be claimed (either as a billed or an allocated cost) under Federal awards and will be documented as described in section E. Costs of central services omitted from the plan will not be reimbursed.

D. SUBMISSION REQUIREMENTS

1. Each state will submit a plan to the Department of Health and Human Services for each year in which it claims central service costs under Federal awards. The plan should include (a) a projection of the next year's allocated central service cost (based either on actual costs for the most recently completed year or the budget projection for the coming year), and (b) a reconciliation of actual allocated central service costs to the estimated costs used for either the most recently completed year or the year immediately preceding the most recently completed year.

2. Each major local government is also required to submit a plan to its cognizant agency for indirect costs annually.

3. All other local governments claiming central service costs must develop a plan in accordance with the requirements described in this Part and maintain the plan and related supporting documentation for audit. These local governments are not required to submit their plans for Federal approval unless they are specifically requested to do so by the cognizant agency for indirect costs. Where a local government only receives funds as a subrecipient, the pass-through entity will be responsible for monitoring the subrecipient's plan.

4. All central service cost allocation plans will be prepared and, when required, submitted within six months prior to the beginning of each of the governmental unit's fiscal years in which it proposes to claim central service costs. Extensions may be granted by the cognizant agency for indirect costs on a case-by-case basis.

E. DOCUMENTATION REQUIREMENTS FOR SUBMITTED PLANS

The documentation requirements described in this section may be modified, expanded, or reduced by the cognizant agency for indirect costs on a case-by-case basis. For example, the requirements may be reduced for those central services which have little or no impact on Federal awards. Conversely, if a review of a plan indicates that certain additional information is needed, and will likely be needed in future years, it may be routinely requested in future plan submissions. Items marked with an asterisk (*) should be submitted only once; subsequent plans should merely indicate any changes since the last plan.

1. General

All proposed plans must be accompanied by the following: an organization chart sufficiently detailed to show operations including the central service activities of the state/local government whether or not they are shown as benefiting from central service functions; a copy of the Comprehensive Annual Financial Report (or a copy of the Executive Budget if budgeted costs are being proposed) to support the allowable costs of each central service activity included in the plan; and, a certification (see subsection 4.) that the plan was prepared in accordance with this Part, contains only allowable costs, and was prepared in a manner that treated similar costs consistently among the various Federal awards and between Federal and non-Federal awards/activities.

2. Allocated Central Services

For each allocation central service*, the plan must also include the following: a brief description of the service, an identification of the unit rendering the service and the operating agencies receiving the service, the items of expense included in the cost of the service, the method used to distribute the cost of the service to benefitted agencies, and a summary schedule showing the allocation of each service to the specific benefitted agencies. If any self-insurance funds or fringe benefits costs are treated as allocated (rather than billed) central services, documentation discussed in subsections 3.b. and c. must also be included.

3. Billed Services

a. *General.* The information described in this section must be provided for all billed central services, including internal service funds, self-insurance funds, and fringe benefit funds.

b. Internal service funds.

(1) For each internal service fund or similar activity with an operating budget of \$5 million or more, the plan must include: a brief description of each service; a balance sheet for each fund based on individual accounts contained in the governmental unit's accounting system; a revenue/expenses statement, with revenues broken out by source, e.g., regular billings, interest earned, etc.; a listing of all non-operating transfers (as defined by Generally Accepted Accounting Principles (GAAP)) into and out of the fund; a description of the procedures (methodology) used to charge the costs of each service to users, including how billing rates are determined; a schedule of current rates; and, a schedule comparing total revenues (including imputed revenues) generated by the service to the allowable costs of the service, as determined under this Part, with an explanation of how variances will be handled.

(2) Revenues must consist of all revenues generated by the service, including unbilled and uncollected revenues. If some users were not billed for the services (or were not billed at the full rate for that class of users), a schedule showing the full imputed revenues associated with these users must be provided. Expenses must be broken out by object cost categories (e.g., salaries, supplies, etc.).

c. *Self-insurance funds.* For each self-insurance fund, the plan must include: the fund balance sheet; a statement of revenue and expenses including a summary of billings and claims paid by agency; a listing of all non-operating transfers into and out of the fund; the type(s) of risk(s) covered by the fund (e.g., automobile liability, workers' compensation, etc.); an explanation of how the level of fund contributions are determined, including a copy of the current actuarial report (with the actuarial assumptions used) if the contributions are determined on an actuarial basis; and, a description of the procedures used to charge or allocate fund contributions to benefitted activities. Reserve levels in excess of claims (1) submitted and adjudicated but not paid, (2) submitted but not adjudicated, and (3) incurred but not submitted must be identified and explained.

d. *Fringe benefits.* For fringe benefit costs, the plan must include: a listing of fringe benefits provided to covered employees, and the overall annual cost of each type of benefit; current fringe benefit policies; and procedures used to charge or allocate the costs of the benefits to benefitted activities. In addition, for pension and post-retirement health insurance plans, the following information must be provided: the governmental unit's funding policies, e.g., legislative bills, trust agreements, or state-mandated contribution rules, if different from actuarially determined rates; the pension plan's costs accrued for the year; the amount funded, and date(s) of funding; a copy of the current actuarial report (including the actuarial assumptions); the plan trustee's report; and, a schedule from the activity showing the value of the interest cost associated with late funding.

4. Required Certification

Each central service cost allocation plan will be accompanied by a certification in the following form:

CERTIFICATE OF COST ALLOCATION PLAN

This is to certify that I have reviewed the cost allocation plan submitted herewith and to the best of my knowledge and belief:

(1) All costs included in this proposal [identify date] to establish cost allocations or billings for [identify period covered by plan] are allowable in accordance with the requirements of this Part and the Federal award(s) to which they apply. Unallowable costs have been adjusted for in allocating costs as indicated in the cost allocation plan.

(2) All costs included in this proposal are properly allocable to Federal awards on the basis of a beneficial or causal relationship between the expenses incurred and the Federal awards to which they are allocated in accordance with applicable requirements. Further, the same costs that have been treated as indirect costs have not been claimed as direct costs. Similar types of costs have been accounted for consistently.

I declare that the foregoing is true and correct.

Governmental Unit:

Signature:

Name of Official:

Title:

Date of Execution:

F. NEGOTIATION AND APPROVAL OF CENTRAL SERVICE PLANS

1. Federal Cognizant Agency for Indirect Costs Assignments for Cost Negotiation

In general, unless different arrangements are agreed to by the concerned Federal agencies, for central service cost allocation plans, the cognizant agency responsible for review and approval is the Federal agency with the largest dollar value of total Federal awards with a governmental unit. For indirect cost rates and departmental indirect cost allocation plans, the cognizant agency is the Federal agency with the largest dollar value of direct Federal awards with a governmental unit or component, as appropriate. Once designated as the cognizant agency for indirect costs, the Federal agency must remain so for a period of five years. In addition, the following Federal agencies continue to be responsible for the indicated governmental entities:

Department of Health and Human Services—Public assistance and state-wide cost allocation plans for all states (including the District of Columbia and Puerto Rico), state and local hospitals, libraries and health districts.

Department of the Interior—Indian tribal governments, territorial governments, and state and local park and recreational districts.

Department of Labor—State and local labor departments.

Department of Education—School districts and state and local education agencies.

Department of Agriculture—State and local agriculture departments.

Department of Transportation—State and local airport and port authorities and transit districts.

Department of Commerce—State and local economic development districts.

Department of Housing and Urban Development—State and local housing and development districts.

Environmental Protection Agency—State and local water and sewer districts.

2. Review

All proposed central service cost allocation plans that are required to be submitted will be reviewed, negotiated, and approved by the cognizant agency for indirect costs on a timely basis. The cognizant agency for indirect costs will review the proposal within six months of receipt of the proposal and either negotiate/approve the proposal or advise the governmental unit of the additional documentation needed to support/evaluate the proposed plan or the changes required to make the proposal acceptable. Once an agreement with the governmental unit has been reached, the agreement will be accepted and used by all Federal agencies, unless prohibited or limited by statute. Where a Federal awarding agency has reason to believe that special operating factors affecting its Federal awards necessitate special consideration, the funding agency will, prior to the time the plans are negotiated, notify the cognizant agency for indirect costs.

3. Agreement

The results of each negotiation must be formalized in a written agreement between the cognizant agency for indirect costs and the governmental unit. This agreement will be subject to re-opening if the agreement is subsequently found to violate a statute or the information upon which the plan was negotiated is later found to be materially incomplete or inaccurate. The results of the negotiation must be made available to all Federal agencies for their use.

4. Adjustments

Negotiated cost allocation plans based on a proposal later found to have included costs that: (a) are unallowable (i) as specified by law or regulation, (ii) as identified in subpart F, General Provisions for selected Items of Cost of this Part, or (iii) by the terms and conditions of Federal awards, or (b) are unallowable because they are clearly not allocable to Federal awards, must be adjusted, or a refund must be made at the option of the cognizant agency for indirect costs, including earned or imputed interest from the date of transfer and debt interest, if applicable, chargeable in accordance with applicable Federal cognizant agency for indirect costs regulations. Adjustments or cash refunds may include, at the option of the cognizant agency for indirect costs, earned or imputed interest from the date of expenditure and delinquent debt interest, if applicable, chargeable in accordance with applicable cognizant agency claims collection regulations. These adjustments or refunds are designed to correct the plans and do not constitute a reopening of the negotiation.

G. OTHER POLICIES

1. Billed Central Service Activities

Each billed central service activity must separately account for all revenues (including imputed revenues) generated by the service, expenses incurred to furnish the service, and profit/loss.

2. Working Capital Reserves

Internal service funds are dependent upon a reasonable level of working capital reserve to operate from one billing cycle to the next. Charges by an internal service activity to provide for the establishment and maintenance of a reasonable level of working capital reserve, in addition to the full recovery of costs, are allowable. A working capital reserve as part of retained earnings of up to 60 calendar days cash expenses for normal operating purposes is considered reasonable. A working capital reserve exceeding 60 calendar days may be approved by the cognizant agency for indirect costs in exceptional cases.

3. Carry-Forward Adjustments of Allocated Central Service Costs

Allocated central service costs are usually negotiated and approved for a future fiscal year on a “fixed with carry-forward” basis. Under this procedure, the fixed amounts for the future year covered by agreement are not subject to adjustment for that year. However, when the actual costs of the year involved become known, the differences between the fixed amounts previously approved and the actual costs will be carried forward and used as an adjustment to the fixed amounts established for a later year. This “carry-forward” procedure applies to all central services whose costs were fixed in the approved plan. However, a carry-forward adjustment is not permitted, for a central service activity that was not included in the approved plan, or for unallowable costs that must be reimbursed immediately.

4. Adjustments of Billed Central Services

Billing rates used to charge Federal awards must be based on the estimated costs of providing the services, including an estimate of the allocable central service costs. A comparison of the revenue generated by each billed service (including total revenues whether or not billed or collected) to the actual allowable costs of the service will be made at least annually, and an adjustment will be made for the difference between the revenue and the allowable costs. These adjustments will be made through one of the following adjustment methods: (a) a cash refund including earned or imputed interest from the date of transfer and debt interest, if applicable, chargeable in accordance with applicable Federal cognizant agency for indirect costs regulations to the Federal Government for the Federal share of the adjustment, (b) credits to the amounts charged to the individual programs, (c) adjustments to future billing rates, or (d) adjustments to allocated central service costs. Adjustments to allocated central services will not be permitted where the total amount of the adjustment for a particular service (Federal share and non-Federal) share exceeds \$500,000. Adjustment methods may include, at the option of the cognizant agency, earned or imputed interest from the date of expenditure and delinquent debt interest, if applicable, chargeable in accordance with applicable cognizant agency claims collection regulations.

5. Records Retention

All central service cost allocation plans and related documentation used as a basis for claiming costs under Federal awards must be retained for audit in accordance with the records retention requirements contained in Subpart D—Post Federal Award Requirements, of Part 200.

6. Appeals

If a dispute arises in the negotiation of a plan between the cognizant agency for indirect costs and the governmental unit, the dispute must be resolved in accordance with the appeals procedures of the cognizant agency for indirect costs.

7. OMB Assistance

To the extent that problems are encountered among the Federal agencies or governmental units in connection with the negotiation and approval process, OMB will lend assistance, as required, to resolve such problems in a timely manner.

[↑ Back to Top](#)

Appendix VI to Part 200—Public Assistance Cost Allocation Plans

A. GENERAL

Federally-financed programs administered by state public assistance agencies are funded predominately by the Department of Health and Human Services (HHS). In support of its stewardship requirements, HHS has published requirements for the development, documentation, submission, negotiation, and approval of public assistance cost allocation plans in Subpart E of 45 CFR Part 95. All administrative costs (direct and indirect) are normally charged to Federal awards by implementing the public assistance cost allocation plan. This Appendix extends these requirements to all Federal awarding agencies whose programs are administered by a state public assistance agency. Major federally-financed programs typically administered by state public assistance agencies include: Temporary Aid to Needy Families (TANF), Medicaid, Food Stamps, Child Support Enforcement, Adoption Assistance and Foster Care, and Social Services Block Grant.

B. DEFINITIONS

1. *State public assistance agency* means a state agency administering or supervising the administration of one or more public assistance programs operated by the state as identified in Subpart E of 45 CFR Part 95. For the purpose of this Appendix, these programs include all programs administered by the state public assistance agency.

2. *State public assistance agency costs* means all costs incurred by, or allocable to, the state public assistance agency, except expenditures for financial assistance, medical contractor payments, food stamps, and payments for services and goods provided directly to program recipients.

C. POLICY

State public assistance agencies will develop, document and implement, and the Federal Government will review, negotiate, and approve, public assistance cost allocation plans in accordance with Subpart E of 45 CFR Part 95. The plan will include all programs administered by the state public assistance agency. Where a letter of approval or disapproval is transmitted to a state public assistance agency in accordance with Subpart E, the letter will apply to all Federal agencies and programs. The remaining sections of this Appendix (except for the requirement for certification) summarize the provisions of Subpart E of 45 CFR Part 95.

D. SUBMISSION, DOCUMENTATION, AND APPROVAL OF PUBLIC ASSISTANCE COST ALLOCATION PLANS

1. State public assistance agencies are required to promptly submit amendments to the cost allocation plan to HHS for review and approval.

2. Under the coordination process outlined in section E, Review of Implementation of Approved Plans, affected Federal agencies will review all new plans and plan amendments and provide comments, as appropriate, to HHS. The effective date of the plan or plan amendment will be the first day of the calendar quarter following the event that required the amendment, unless another date is specifically approved by HHS. HHS, as the cognizant agency for indirect costs acting on behalf of all affected Federal agencies, will, as necessary, conduct negotiations with the state public assistance agency and will inform the state agency of the action taken on the plan or plan amendment.

E. REVIEW OF IMPLEMENTATION OF APPROVED PLANS

1. Since public assistance cost allocation plans are of a narrative nature, the review during the plan approval process consists of evaluating the appropriateness of the proposed groupings of costs (cost centers) and the related allocation bases. As such, the Federal Government needs some assurance that the cost allocation plan has been implemented as approved. This is accomplished by reviews by the Federal awarding agencies, single audits, or audits conducted by the the cognizant agency for indirect costs.

2. Where inappropriate charges affecting more than one Federal awarding agency are identified, the cognizant HHS cost negotiation office will be advised and will take the lead in resolving the issue(s) as provided for in Subpart E of 45 CFR Part 95.

3. If a dispute arises in the negotiation of a plan or from a disallowance involving two or more Federal awarding agencies, the dispute must be resolved in accordance with the appeals procedures set out in 45 CFR Part 16. Disputes involving only one Federal awarding agency will be resolved in accordance with the Federal awarding agency's appeal process.

4. To the extent that problems are encountered among the Federal awarding agencies or governmental units in connection with the negotiation and approval process, the Office of Management and Budget will lend assistance, as required, to resolve such problems in a timely manner.

F. UNALLOWABLE COSTS

Claims developed under approved cost allocation plans will be based on allowable costs as identified in this Part. Where unallowable costs have been claimed and reimbursed, they will be refunded to the program that reimbursed the unallowable cost using one of the following methods: (a) a cash refund, (b) offset to a subsequent claim, or (c) credits to the amounts charged to individual Federal awards. Cash refunds, offsets, and credits may include at the option of the cognizant agency for indirect cost, earned or imputed interest from the date of expenditure and delinquent debt interest, if applicable, chargeable in accordance with applicable cognizant agency for indirect cost claims collection regulations.

[↑ Back to Top](#)

Appendix VII to Part 200—States and Local Government and Indian Tribe Indirect Cost Proposals

A. GENERAL

1. Indirect costs are those that have been incurred for common or joint purposes. These costs benefit more than one cost objective and cannot be readily identified with a particular final cost objective without effort disproportionate to the results achieved. After direct costs have been determined and assigned directly to Federal awards and other activities as appropriate, indirect costs are those remaining to be allocated to benefitted cost objectives. A cost may not be allocated to a Federal award as an indirect cost if any other cost incurred for the same purpose, in like circumstances, has been assigned to a Federal award as a direct cost.

2. Indirect costs include (a) the indirect costs originating in each department or agency of the governmental unit carrying out Federal awards and (b) the costs of central governmental services distributed through the central service cost allocation plan (as described in Appendix V to Part 200—State/Local Government and Indian Tribe-Wide Central Service Cost Allocation Plans) and not otherwise treated as direct costs.

3. Indirect costs are normally charged to Federal awards by the use of an indirect cost rate. A separate indirect cost rate(s) is usually necessary for each department or agency of the governmental unit claiming indirect costs under Federal awards. Guidelines and illustrations of indirect cost proposals are provided in a brochure published by the Department of Health and Human Services entitled "*A Guide for States and Local Government Agencies: Cost Principles and Procedures for Establishing Cost Allocation Plans and Indirect Cost Rates for Grants and Contracts with the Federal Government.*" A copy of this brochure may be obtained from the HHS Cost Allocation Services or at their Web site at <https://rates.psc.gov>.

4. Because of the diverse characteristics and accounting practices of governmental units, the types of costs which may be classified as indirect costs cannot be specified in all situations. However, typical examples of indirect costs may include certain state/local-wide central service costs, general administration of the non-Federal entity accounting and personnel services performed within the non-Federal entity, depreciation on buildings and equipment, the costs of operating and maintaining facilities.

5. This Appendix does not apply to state public assistance agencies. These agencies should refer instead to Appendix VI to Part 200—Public Assistance Cost Allocation Plans.

B. DEFINITIONS

1. *Base* means the accumulated direct costs (normally either total direct salaries and wages or total direct costs exclusive of any extraordinary or distorting expenditures) used to distribute indirect costs to individual Federal awards. The direct cost base selected should result in each Federal award bearing a fair share of the indirect costs in reasonable relation to the benefits received from the costs.

2. *Base period* for the allocation of indirect costs is the period in which such costs are incurred and accumulated for allocation to activities performed in that period. The base period normally should coincide with the governmental unit's fiscal year, but in any event, must be so selected as to avoid inequities in the allocation of costs.

3. *Cognizant agency for indirect costs* means the Federal agency responsible for reviewing and approving the governmental unit's indirect cost rate(s) on the behalf of the Federal Government. The cognizant agency for indirect costs assignment is described in Appendix V, section F, Negotiation and Approval of Central Service Plans.

4. *Final rate* means an indirect cost rate applicable to a specified past period which is based on the actual allowable costs of the period. A final audited rate is not subject to adjustment.

5. *Fixed rate* means an indirect cost rate which has the same characteristics as a predetermined rate, except that the difference between the estimated costs and the actual, allowable costs of the period covered by the rate is carried forward as an adjustment to the rate computation of a subsequent period.

6. *Indirect cost pool* is the accumulated costs that jointly benefit two or more programs or other cost objectives.

7. *Indirect cost rate* is a device for determining in a reasonable manner the proportion of indirect costs each program should bear. It is the ratio (expressed as a percentage) of the indirect costs to a direct cost base.

8. *Indirect cost rate proposal* means the documentation prepared by a governmental unit or subdivision thereof to substantiate its request for the establishment of an indirect cost rate.

9. *Predetermined rate* means an indirect cost rate, applicable to a specified current or future period, usually the governmental unit's fiscal year. This rate is based on an estimate of the costs to be incurred during the period. Except under very unusual circumstances, a predetermined rate is not subject to adjustment. (Because of legal constraints, predetermined rates are not permitted for Federal contracts; they may, however, be used for grants or cooperative agreements.) Predetermined rates may not be used by governmental units that have not submitted and negotiated the rate with the cognizant agency for indirect costs. In view of the potential advantages offered by this procedure, negotiation of predetermined rates for indirect costs for a period of two to four years should be the norm in those situations where the cost experience and other pertinent facts available are deemed sufficient to enable the parties involved to reach an informed judgment as to the probable level of indirect costs during the ensuing accounting periods.

10. *Provisional rate* means a temporary indirect cost rate applicable to a specified period which is used for funding, interim reimbursement, and reporting indirect costs on Federal awards pending the establishment of a "final" rate for that period.

C. ALLOCATION OF INDIRECT COSTS AND DETERMINATION OF INDIRECT COST RATES

1. General

a. Where a governmental unit's department or agency has only one major function, or where all its major functions benefit from the indirect costs to approximately the same degree, the allocation of indirect costs and the computation of an indirect cost rate may be accomplished through simplified allocation procedures as described in subsection 2.

b. Where a governmental unit's department or agency has several major functions which benefit from its indirect costs in varying degrees, the allocation of indirect costs may require the accumulation of such costs into separate cost groupings which then are allocated individually to benefitted functions by means of a base which best measures the relative degree of benefit. The indirect costs allocated to each function are then distributed to individual Federal awards and other activities included in that function by means of an indirect cost rate(s).

c. Specific methods for allocating indirect costs and computing indirect cost rates along with the conditions under which each method should be used are described in subsections 2, 3 and 4.

2. Simplified Method

a. Where a non-Federal entity's major functions benefit from its indirect costs to approximately the same degree, the allocation of indirect costs may be accomplished by (1) classifying the non-Federal entity's total costs for the base period as either direct or indirect, and (2) dividing the total allowable indirect costs (net of applicable credits) by an equitable distribution base. The result of this process is an indirect cost rate which is used to distribute indirect costs to individual Federal awards. The rate should be expressed as the percentage which the total amount of allowable indirect costs bears to the base selected. This method should also be used where a governmental unit's department or agency has only one major function encompassing a number of individual projects or activities, and may be used where the level of Federal awards to that department or agency is relatively small.

b. Both the direct costs and the indirect costs must exclude capital expenditures and unallowable costs. However, unallowable costs must be included in the direct costs if they represent activities to which indirect costs are properly allocable.

c. The distribution base may be (1) total direct costs (excluding capital expenditures and other distorting items, such as pass-through funds, subcontracts in excess of \$25,000, participant support costs, etc.), (2) direct salaries and wages, or (3) another base which results in an equitable distribution.

3. Multiple Allocation Base Method

a. Where a non-Federal entity's indirect costs benefit its major functions in varying degrees, such costs must be accumulated into separate cost groupings. Each grouping must then be allocated individually to benefitted functions by means of a base which best measures the relative benefits.

b. The cost groupings should be established so as to permit the allocation of each grouping on the basis of benefits provided to the major functions. Each grouping should constitute a pool of expenses that are of like character in terms of the functions they benefit and in terms of the allocation base which best measures the relative benefits provided to each function. The number of separate groupings should be held within practical limits, taking into consideration the materiality of the amounts involved and the degree of precision needed.

c. Actual conditions must be taken into account in selecting the base to be used in allocating the expenses in each grouping to benefitted functions. When an allocation can be made by assignment of a cost grouping directly to the function benefitted, the allocation must be made in that manner. When the expenses in a grouping are more general in nature, the allocation should be made through the use of a selected base which produces results that are equitable to both the Federal Government and the governmental unit. In general, any cost element or related factor associated with the governmental unit's activities is potentially adaptable for use as an allocation base provided that: (1) it can readily be expressed in terms of dollars or other quantitative measures (total direct costs, direct salaries and wages, staff hours applied, square feet used, hours of usage, number of documents processed, population served, and the like), and (2) it is common to the benefitted functions during the base period.

d. Except where a special indirect cost rate(s) is required in accordance with paragraph (C)(4) of this Appendix, the separate groupings of indirect costs allocated to each major function must be aggregated and treated as a common pool for that function. The costs in the common pool must then be distributed to individual Federal awards included in that function by use of a single indirect cost rate.

e. The distribution base used in computing the indirect cost rate for each function may be (1) total direct costs (excluding capital expenditures and other distorting items such as pass-through funds, subawards in excess of \$25,000, participant support costs, etc.), (2) direct

salaries and wages, or (3) another base which results in an equitable distribution. An indirect cost rate should be developed for each separate indirect cost pool developed. The rate in each case should be stated as the percentage relationship between the particular indirect cost pool and the distribution base identified with that pool.

4. *Special Indirect Cost Rates*

a. In some instances, a single indirect cost rate for all activities of a non-Federal entity or for each major function of the agency may not be appropriate. It may not take into account those different factors which may substantially affect the indirect costs applicable to a particular program or group of programs. The factors may include the physical location of the work, the level of administrative support required, the nature of the facilities or other resources employed, the organizational arrangements used, or any combination thereof. When a particular Federal award is carried out in an environment which appears to generate a significantly different level of indirect costs, provisions should be made for a separate indirect cost pool applicable to that Federal award. The separate indirect cost pool should be developed during the course of the regular allocation process, and the separate indirect cost rate resulting therefrom should be used, provided that: (1) The rate differs significantly from the rate which would have been developed under paragraphs (C)(2) and (C)(3) of this Appendix, and (2) the Federal award to which the rate would apply is material in amount.

b. Where Federal statutes restrict the reimbursement of certain indirect costs, it may be necessary to develop a special rate for the affected Federal award. Where a "restricted rate" is required, the same procedure for developing a non-restricted rate will be used except for the additional step of the elimination from the indirect cost pool those costs for which the law prohibits reimbursement.

D. SUBMISSION AND DOCUMENTATION OF PROPOSALS

1. *Submission of Indirect Cost Rate Proposals*

a. All departments or agencies of the governmental unit desiring to claim indirect costs under Federal awards must prepare an indirect cost rate proposal and related documentation to support those costs. The proposal and related documentation must be retained for audit in accordance with the records retention requirements contained in §200.333 Retention Requirements for Records.

b. A governmental department or agency unit that receives more than \$35 million in direct Federal funding must submit its indirect cost rate proposal to its cognizant agency for indirect costs. Other governmental department or agency must develop an indirect cost proposal in accordance with the requirements of this Part and maintain the proposal and related supporting documentation for audit. These governmental departments or agencies are not required to submit their proposals unless they are specifically requested to do so by the cognizant agency for indirect costs. Where a non-Federal entity only receives funds as a subrecipient, the pass-through entity will be responsible for negotiating and/or monitoring the subrecipient's indirect costs.

c. Each Indian tribal government desiring reimbursement of indirect costs must submit its indirect cost proposal to the Department of the Interior (its cognizant agency for indirect costs).

d. Indirect cost proposals must be developed (and, when required, submitted) within six months after the close of the governmental unit's fiscal year, unless an exception is approved by the cognizant agency for indirect costs. If the proposed central service cost allocation plan for the same period has not been approved by that time, the indirect cost proposal may be prepared including an amount for central services that is based on the latest federally-approved central service cost allocation plan. The difference between these central service amounts and the amounts ultimately approved will be compensated for by an adjustment in a subsequent period.

2. *Documentation of Proposals*

The following must be included with each indirect cost proposal:

a. The rates proposed, including subsidiary work sheets and other relevant data, cross referenced and reconciled to the financial data noted in subsection b. Allocated central service costs will be supported by the summary table included in the approved central service cost allocation plan. This summary table is not required to be submitted with the indirect cost proposal if the central service cost allocation plan for the same fiscal year has been approved by the cognizant agency for indirect costs and is available to the funding agency.

b. A copy of the financial data (financial statements, comprehensive annual financial report, executive budgets, accounting reports, etc.) upon which the rate is based. Adjustments resulting from the use of unaudited data will be recognized, where appropriate, by the Federal cognizant agency for indirect costs in a subsequent proposal.

c. The approximate amount of direct base costs incurred under Federal awards. These costs should be broken out between salaries and wages and other direct costs.

d. A chart showing the organizational structure of the agency during the period for which the proposal applies, along with a functional statement(s) noting the duties and/or responsibilities of all units that comprise the agency. (Once this is submitted, only revisions need be submitted with subsequent proposals.)

3. *Required certification.*

Each indirect cost rate proposal must be accompanied by a certification in the following form:

CERTIFICATE OF INDIRECT COSTS

This is to certify that I have reviewed the indirect cost rate proposal submitted herewith and to the best of my knowledge and belief:

(1) All costs included in this proposal [identify date] to establish billing or final indirect costs rates for [identify period covered by rate] are allowable in accordance with the requirements of the Federal award(s) to which they apply and the provisions of this Part. Unallowable costs have been adjusted for in allocating costs as indicated in the indirect cost proposal

(2) All costs included in this proposal are properly allocable to Federal awards on the basis of a beneficial or causal relationship between the expenses incurred and the agreements to which they are allocated in accordance with applicable requirements. Further, the same costs that have been treated as indirect costs have not been claimed as direct costs. Similar types of costs have been accounted for consistently and the Federal Government will be notified of any accounting changes that would affect the predetermined rate.

I declare that the foregoing is true and correct.

Governmental Unit:

Signature:

Name of Official:

Title:

Date of Execution:

E. NEGOTIATION AND APPROVAL OF RATES.

1. Indirect cost rates will be reviewed, negotiated, and approved by the cognizant agency on a timely basis. Once a rate has been agreed upon, it will be accepted and used by all Federal agencies unless prohibited or limited by statute. Where a Federal awarding agency has reason to believe that special operating factors affecting its Federal awards necessitate special indirect cost rates, the funding agency will, prior to the time the rates are negotiated, notify the cognizant agency for indirect costs.

2. The use of predetermined rates, if allowed, is encouraged where the cognizant agency for indirect costs has reasonable assurance based on past experience and reliable projection of the non-Federal entity's costs, that the rate is not likely to exceed a rate based on actual costs. Long-term agreements utilizing predetermined rates extending over two or more years are encouraged, where appropriate.

3. The results of each negotiation must be formalized in a written agreement between the cognizant agency for indirect costs and the governmental unit. This agreement will be subject to re-opening if the agreement is subsequently found to violate a statute, or the information upon which the plan was negotiated is later found to be materially incomplete or inaccurate. The agreed upon rates must be made available to all Federal agencies for their use.

4. Refunds must be made if proposals are later found to have included costs that (a) are unallowable (i) as specified by law or regulation, (ii) as identified in §200.420 Considerations for selected items of cost, of this Part, or (iii) by the terms and conditions of Federal awards, or (b) are unallowable because they are clearly not allocable to Federal awards. These adjustments or refunds will be made regardless of the type of rate negotiated (predetermined, final, fixed, or provisional).

F. OTHER POLICIES

1. Fringe Benefit Rates

If overall fringe benefit rates are not approved for the governmental unit as part of the central service cost allocation plan, these rates will be reviewed, negotiated and approved for individual recipient agencies during the indirect cost negotiation process. In these cases, a proposed fringe benefit rate computation should accompany the indirect cost proposal. If fringe benefit rates are not used at the recipient agency level (i.e., the agency specifically identifies fringe benefit costs to individual employees), the governmental unit should so advise the cognizant agency for indirect costs.

2. Billed Services Provided by the Recipient Agency

In some cases, governmental departments or agencies (components of the governmental unit) provide and bill for services similar to those covered by central service cost allocation plans (e.g., computer centers). Where this occurs, the governmental departments or agencies (components of the governmental unit) should be guided by the requirements in Appendix V relating to the development of billing rates and documentation requirements, and should advise the cognizant agency for indirect costs of any billed services. Reviews of these types of services (including reviews of costing/billing methodology, profits or losses, etc.) will be made on a case-by-case basis as warranted by the circumstances involved.

3. Indirect Cost Allocations Not Using Rates

In certain situations, governmental departments or agencies (components of the governmental unit), because of the nature of their Federal awards, may be required to develop a cost allocation plan that distributes indirect (and, in some cases, direct) costs to the specific funding sources. In these cases, a narrative cost allocation methodology should be developed, documented, maintained for audit, or submitted, as appropriate, to the cognizant agency for indirect costs for review, negotiation, and approval.

4. Appeals

If a dispute arises in a negotiation of an indirect cost rate (or other rate) between the cognizant agency for indirect costs and the governmental unit, the dispute must be resolved in accordance with the appeals procedures of the cognizant agency for indirect costs.

5. Collection of Unallowable Costs and Erroneous Payments

Costs specifically identified as unallowable and charged to Federal awards either directly or indirectly will be refunded (including interest chargeable in accordance with applicable Federal cognizant agency for indirect costs regulations).

6. OMB Assistance

To the extent that problems are encountered among the Federal agencies or governmental units in connection with the negotiation and approval process, OMB will lend assistance, as required, to resolve such problems in a timely manner.

[78 FR 78608, Dec. 26, 2013, as amended at 79 FR 75889, Dec. 19, 2014]

[↑ Back to Top](#)

Appendix VIII to Part 200—Nonprofit Organizations Exempted From Subpart E—Cost Principles of Part 200

1. Advance Technology Institute (ATI), Charleston, South Carolina
2. Aerospace Corporation, El Segundo, California
3. American Institutes of Research (AIR), Washington, DC

4. Argonne National Laboratory, Chicago, Illinois
5. Atomic Casualty Commission, Washington, DC
6. Battelle Memorial Institute, Headquartered in Columbus, Ohio
7. Brookhaven National Laboratory, Upton, New York
8. Charles Stark Draper Laboratory, Incorporated, Cambridge, Massachusetts
9. CNA Corporation (CNAC), Alexandria, Virginia
10. Environmental Institute of Michigan, Ann Arbor, Michigan
11. Georgia Institute of Technology/Georgia Tech Applied Research Corporation/Georgia Tech Research Institute, Atlanta, Georgia
12. Hanford Environmental Health Foundation, Richland, Washington
13. IIT Research Institute, Chicago, Illinois
14. Institute of Gas Technology, Chicago, Illinois
15. Institute for Defense Analysis, Alexandria, Virginia
16. LMI, McLean, Virginia
17. Mitre Corporation, Bedford, Massachusetts
18. Noblis, Inc., Falls Church, Virginia
19. National Radiological Astronomy Observatory, Green Bank, West Virginia
20. National Renewable Energy Laboratory, Golden, Colorado
21. Oak Ridge Associated Universities, Oak Ridge, Tennessee
22. Rand Corporation, Santa Monica, California
23. Research Triangle Institute, Research Triangle Park, North Carolina
24. Riverside Research Institute, New York, New York
25. South Carolina Research Authority (SCRA), Charleston, South Carolina
26. Southern Research Institute, Birmingham, Alabama
27. Southwest Research Institute, San Antonio, Texas
28. SRI International, Menlo Park, California
29. Syracuse Research Corporation, Syracuse, New York
30. Universities Research Association, Incorporated (National Acceleration Lab), Argonne, Illinois
31. Urban Institute, Washington DC
32. Non-profit insurance companies, such as Blue Cross and Blue Shield Organizations
33. Other non-profit organizations as negotiated with Federal awarding agencies

[↑ Back to Top](#)

Appendix IX to Part 200—Hospital Cost Principles

Based on initial feedback, OMB proposes to establish a review process to consider existing hospital cost determine how best to update and align them with this Part. Until such time as revised guidance is proposed and implemented for hospitals, the existing principles located at 45 CFR Part 75 Appendix E, entitled “Principles for Determining Cost Applicable to Research and Development Under Grants and Contracts with Hospitals,” remain in effect.

[78 FR 78608, Dec. 26, 2013, as amended at 79 FR 75889, Dec. 19, 2014]

[↑ Back to Top](#)

Appendix X to Part 200—Data Collection Form (Form SF-SAC)

The Data Collection Form SF-SAC is available on the FAC Web site.

[↑ Back to Top](#)

Appendix XI to Part 200—Compliance Supplement

The compliance supplement is available on the OMB Web site: (e.g. for 2013 here <http://www.whitehouse.gov/omb/circulars/>)

[↑ Back to Top](#)

[Need assistance?](#)

2 C.F.R. § 200.326 and 2 C.F.R. Part 200, Appendix II, Required Contract Clauses

Requirements under the Uniform Rules. A non-Federal entity's contracts must contain the applicable contract clauses described in Appendix II to the Uniform Rules (Contract Provisions for non-Federal Entity Contracts Under Federal Awards), which are set forth below. 2 C.F.R. § 200.326. For some of the required clauses we have included sample language or a reference a non-Federal entity can go to in order to find sample language. Please be aware that this is sample language only and that the non-Federal entity alone is responsible ensuring that all language included in their contracts meets the requirements of 2 C.F.R. § 200.326 and 2 C.F.R. Part 200, Appendix II. We do not include sample language for certain required clauses (remedies, termination for cause and convenience, changes) as these must necessarily be written based on the non-Federal entity's own procedures in that area.

1. Remedies.

- a. Standard: Contracts for more than the simplified acquisition threshold (\$150,000) must address administrative, contractual, or legal remedies in instances where contractors violate or breach contract terms, and provide for such sanctions and penalties as appropriate. See 2 C.F.R. Part 200, Appendix II, ¶ A.
- b. Applicability: This requirement applies to all FEMA grant and cooperative agreement programs.

2. Termination for Cause and Convenience.

- a. All contracts in excess of \$10,000 must address termination for cause and for convenience by the non-Federal entity including the manner by which it will be effected and the basis for settlement. See 2 C.F.R. Part 200, Appendix II, ¶ B.
- b. Applicability. This requirement applies to all FEMA grant and cooperative agreement programs.

3. Equal Employment Opportunity.

- a. Standard. Except as otherwise provided under 41 C.F.R. Part 60, all contracts that meet the definition of "federally assisted construction contract" in 41 C.F.R. § 60-1.3 must include the equal opportunity clause provided under 41 C.F.R. § 60-1.4(b), in accordance with Executive Order 11246, *Equal Employment Opportunity* (30 Fed. Reg. 12319, 12935, 3 C.F.R. Part, 1964-1965 Comp., p. 339), as amended by Executive Order 11375, *Amending Executive Order 11246 Relating to Equal Employment Opportunity*, and implementing regulations at 41 C.F.R. Part 60 (Office of Federal Contract Compliance Programs, Equal Employment Opportunity, Department of Labor). See 2 C.F.R. Part 200, Appendix II, ¶ C.
- b. Key Definitions.

- (1) Federally Assisted Construction Contract. The regulation at 41 C.F.R. § 60-1.3 defines a “federally assisted construction contract” as any agreement or modification thereof between any applicant and a person for construction work which is paid for in whole or in part with funds obtained from the Government or borrowed on the credit of the Government pursuant to any Federal program involving a grant, contract, loan, insurance, or guarantee, or undertaken pursuant to any Federal program involving such grant, contract, loan, insurance, or guarantee, or any application or modification thereof approved by the Government for a grant, contract, loan, insurance, or guarantee under which the applicant itself participates in the construction work.
 - (2) Construction Work. The regulation at 41 C.F.R. § 60-1.3 defines “construction work” as the construction, rehabilitation, alteration, conversion, extension, demolition or repair of buildings, highways, or other changes or improvements to real property, including facilities providing utility services. The term also includes the supervision, inspection, and other onsite functions incidental to the actual construction.
- c. Applicability. This requirement applies to all FEMA grant and cooperative agreement programs.
- d. The regulation at 41 C.F.R. Part 60-1.4(b) requires the insertion of the following contract clause:
- “During the performance of this contract, the contractor agrees as follows:
- (1) The contractor will not discriminate against any employee or applicant for employment because of race, color, religion, sex, or national origin. The contractor will take affirmative action to ensure that applicants are employed, and that employees are treated during employment without regard to their race, color, religion, sex, or national origin. Such action shall include, but not be limited to the following: Employment, upgrading, demotion, or transfer; recruitment or recruitment advertising; layoff or termination; rates of pay or other forms of compensation; and selection for training, including apprenticeship. The contractor agrees to post in conspicuous places, available to employees and applicants for employment, notices to be provided setting forth the provisions of this nondiscrimination clause.
 - (2) The contractor will, in all solicitations or advertisements for employees placed by or on behalf of the contractor, state that all qualified applicants will receive considerations for employment without regard to race, color, religion, sex, or national origin.
 - (3) The contractor will send to each labor union or representative of workers with which he has a collective bargaining agreement or other contract or understanding, a notice to be provided advising the said labor union or workers' representatives of the contractor's commitments under this section,

and shall post copies of the notice in conspicuous places available to employees and applicants for employment.

- (4) The contractor will comply with all provisions of Executive Order 11246 of September 24, 1965, and of the rules, regulations, and relevant orders of the Secretary of Labor.
- (5) The contractor will furnish all information and reports required by Executive Order 11246 of September 24, 1965, and by rules, regulations, and orders of the Secretary of Labor, or pursuant thereto, and will permit access to his books, records, and accounts by the administering agency and the Secretary of Labor for purposes of investigation to ascertain compliance with such rules, regulations, and orders.
- (6) In the event of the contractor's noncompliance with the nondiscrimination clauses of this contract or with any of the said rules, regulations, or orders, this contract may be canceled, terminated, or suspended in whole or in part and the contractor may be declared ineligible for further Government contracts or federally assisted construction contracts in accordance with procedures authorized in Executive Order 11246 of September 24, 1965, and such other sanctions as may be imposed and remedies invoked as provided in Executive Order 11246 of September 24, 1965, or by rule, regulation, or order of the Secretary of Labor, or as otherwise provided by law.
- (7) The contractor will include the portion of the sentence immediately preceding paragraph (1) and the provisions of paragraphs (1) through (7) in every subcontract or purchase order unless exempted by rules, regulations, or orders of the Secretary of Labor issued pursuant to section 204 of Executive Order 11246 of September 24, 1965, so that such provisions will be binding upon each subcontractor or vendor. The contractor will take such action with respect to any subcontract or purchase order as the administering agency may direct as a means of enforcing such provisions, including sanctions for noncompliance: Provided, however, That in the event a contractor becomes involved in, or is threatened with, litigation with a subcontractor or vendor as a result of such direction by the administering agency the contractor may request the United States to enter into such litigation to protect the interests of the United States.”

4. Davis Bacon Act and Copeland Anti-Kickback Act.

- a. Applicability of Davis-Bacon Act. The Davis-Bacon Act only applies to the emergency Management Preparedness Grant Program, Homeland Security Grant Program, Nonprofit Security Grant Program, Tribal Homeland Security Grant Program, Port Security Grant Program, and Transit Security Grant Program. **It does not apply to other FEMA grant and cooperative agreement programs, including the Public Assistance Program.**
- b. All prime construction contracts in excess of \$2,000 awarded by non-Federal entities must include a provision for compliance with the Davis-Bacon Act (40

U.S.C. §§ 3141-3144 and 3146-3148) as supplemented by Department of Labor regulations at 29 C.F.R. Part 5 (Labor Standards Provisions Applicable to Contracts Covering Federally Financed and Assisted Construction)). See 2 C.F.R. Part 200, Appendix II, ¶ D.

- c. In accordance with the statute, contractors must be required to pay wages to laborers and mechanics at a rate not less than the prevailing wages specified in a wage determination made by the Secretary of Labor. In addition, contractors must be required to pay wages not less than once a week.
- d. The non-Federal entity must place a copy of the current prevailing wage determination issued by the Department of Labor in each solicitation. The decision to award a contract or subcontract must be conditioned upon the acceptance of the wage determination. The non-Federal entity must report all suspected or reported violations to the Federal awarding agency.
- e. In contracts subject to the Davis-Bacon Act, the contracts must also include a provision for compliance with the Copeland “Anti-Kickback” Act (40 U.S.C. § 3145), as supplemented by Department of Labor regulations at 29 C.F.R. Part 3 (Contractors and Subcontractors on Public Building or Public Work Financed in Whole or in Part by Loans or Grants from the United States). The Copeland Anti-Kickback Act provides that each contractor or subrecipient must be prohibited from inducing, by any means, any person employed in the construction, completion, or repair of public work, to give up any part of the compensation to which he or she is otherwise entitled. The non-Federal entity must report all suspected or reported violations to FEMA.
- f. The regulation at 29 C.F.R. § 5.5(a) does provide the required contract clause that applies to compliance with both the Davis-Bacon and Copeland Acts. However, as discussed in the previous subsection, the Davis-Bacon Act does not apply to Public Assistance recipients and subrecipients. **In situations where the Davis-Bacon Act does not apply, neither does the Copeland “Anti-Kickback Act.”** However, for purposes of grant programs where both clauses do apply, FEMA requires the following contract clause:

“Compliance with the Copeland “Anti-Kickback” Act.

(1) Contractor. The contractor shall comply with 18 U.S.C. § 874, 40 U.S.C. § 3145, and the requirements of 29 C.F.R. pt. 3 as may be applicable, which are incorporated by reference into this contract.

(2) Subcontracts. The contractor or subcontractor shall insert in any subcontracts the clause above and such other clauses as the FEMA may by appropriate instructions require, and also a clause requiring the subcontractors to include these clauses in any lower tier subcontracts. The prime contractor shall be responsible for the compliance by any subcontractor or lower tier subcontractor with all of these contract clauses.

(3) Breach. A breach of the contract clauses above may be grounds for termination of the contract, and for debarment as a contractor and subcontractor as provided in 29 C.F.R. § 5.12.”

5. Contract Work Hours and Safety Standards Act.

- a. Applicability: This requirement applies to all FEMA grant and cooperative agreement programs.
- b. Where applicable (see 40 U.S.C. § 3701), all contracts awarded by the non-Federal entity in excess of \$100,000 that involve the employment of mechanics or laborers must include a provision for compliance with 40 U.S.C. §§ 3702 and 3704, as supplemented by Department of Labor regulations at 29 C.F.R. Part 5. See 2 C.F.R. Part 200, Appendix II, ¶ E.
- c. Under 40 U.S.C. § 3702, each contractor must be required to compute the wages of every mechanic and laborer on the basis of a standard work week of 40 hours. Work in excess of the standard work week is permissible provided that the worker is compensated at a rate of not less than one and a half times the basic rate of pay for all hours worked in excess of 40 hours in the work week.
- d. The requirements of 40 U.S.C. § 3704 are applicable to construction work and provide that no laborer or mechanic must be required to work in surroundings or under working conditions which are unsanitary, hazardous or dangerous. These requirements do not apply to the purchases of supplies or materials or articles ordinarily available on the open market, or contracts for transportation or transmission of intelligence.
- e. The regulation at 29 C.F.R. § 5.5(b) provides the required contract clause concerning compliance with the Contract Work Hours and Safety Standards Act:

“Compliance with the Contract Work Hours and Safety Standards Act.

- (1) Overtime requirements. No contractor or subcontractor contracting for any part of the contract work which may require or involve the employment of laborers or mechanics shall require or permit any such laborer or mechanic in any workweek in which he or she is employed on such work to work in excess of forty hours in such workweek unless such laborer or mechanic receives compensation at a rate not less than one and one-half times the basic rate of pay for all hours worked in excess of forty hours in such workweek.
- (2) Violation; liability for unpaid wages; liquidated damages. In the event of any violation of the clause set forth in paragraph (1) of this section the contractor and any subcontractor responsible therefor shall be liable for the unpaid wages. In addition, such contractor and subcontractor shall be liable to the United States (in the case of work

done under contract for the District of Columbia or a territory, to such District or to such territory), for liquidated damages. Such liquidated damages shall be computed with respect to each individual laborer or mechanic, including watchmen and guards, employed in violation of the clause set forth in paragraph (1) of this section, in the sum of \$10 for each calendar day on which such individual was required or permitted to work in excess of the standard workweek of forty hours without payment of the overtime wages required by the clause set forth in paragraph (1) of this section.

(3) Withholding for unpaid wages and liquidated damages. The (write in the name of the Federal agency or the loan or grant recipient) shall upon its own action or upon written request of an authorized representative of the Department of Labor withhold or cause to be withheld, from any moneys payable on account of work performed by the contractor or subcontractor under any such contract or any other Federal contract with the same prime contractor, or any other federally-assisted contract subject to the Contract Work Hours and Safety Standards Act, which is held by the same prime contractor, such sums as may be determined to be necessary to satisfy any liabilities of such contractor or subcontractor for unpaid wages and liquidated damages as provided in the clause set forth in paragraph (2) of this section.

(4) Subcontracts. The contractor or subcontractor shall insert in any subcontracts the clauses set forth in paragraph (1) through (4) of this section and also a clause requiring the subcontractors to include these clauses in any lower tier subcontracts. The prime contractor shall be responsible for compliance by any subcontractor or lower tier subcontractor with the clauses set forth in paragraphs (1) through (4) of this section.”

6. Rights to Inventions Made Under a Contract or Agreement.

- a. Stafford Act Disaster Grants. This requirement **does not apply to the Public Assistance**, Hazard Mitigation Grant Program, Fire Management Assistance Grant Program, Crisis Counseling Assistance and Training Grant Program, Disaster Case Management Grant Program, and Federal Assistance to Individuals and Households – Other Needs Assistance Grant Program, as FEMA awards under these programs do not meet the definition of “funding agreement.”
- b. If the FEMA award meets the definition of “funding agreement” under 37 C.F.R. § 401.2(a) and the non-Federal entity wishes to enter into a contract with a small business firm or nonprofit organization regarding the substitution of parties, assignment or performance of experimental, developmental, or research work under that “funding agreement,” the non-Federal entity must comply with the requirements of 37 C.F.R. Part 401 (Rights to Inventions Made by Nonprofit Organizations and Small Business Firms Under Government Grants, Contracts and Cooperative Agreements), and any implementing regulations issued by

FEMA. See 2 C.F.R. Part 200, Appendix II, ¶ F.

- c. The regulation at 37 C.F.R. § 401.2(a) currently defines “funding agreement” as any contract, grant, or cooperative agreement entered into between any Federal agency, other than the Tennessee Valley Authority, and any contractor for the performance of experimental, developmental, or research work funded in whole or in part by the Federal government. This term also includes any assignment, substitution of parties, or subcontract of any type entered into for the performance of experimental, developmental, or research work under a funding agreement as defined in the first sentence of this paragraph.
7. Clean Air Act and the Federal Water Pollution Control Act. Contracts of amounts in excess of \$150,000 must contain a provision that requires the contractor to agree to comply with all applicable standards, orders, or regulations issued pursuant to the Clean Air Act (42 U.S.C. §§ 7401-7671q) and the Federal Water Pollution Control Act as amended (33 U.S.C. §§ 1251-1387). Violations must be reported to FEMA and the Regional Office of the Environmental Protection Agency. See 2 C.F.R. Part 200, Appendix II, ¶ G.
 - a. The following provides a sample contract clause concerning compliance for contracts of amounts in excess of \$150,000:

“Clean Air Act

- (1) The contractor agrees to comply with all applicable standards, orders or regulations issued pursuant to the Clean Air Act, as amended, 42 U.S.C. § 7401 et seq.
- (2) The contractor agrees to report each violation to the (name of the state agency or local or Indian tribal government) and understands and agrees that the (name of the state agency or local or Indian tribal government) will, in turn, report each violation as required to assure notification to the (name of recipient), Federal Emergency Management Agency, and the appropriate Environmental Protection Agency Regional Office.
- (3) The contractor agrees to include these requirements in each subcontract exceeding \$150,000 financed in whole or in part with Federal assistance provided by FEMA.

Federal Water Pollution Control Act

- (1) The contractor agrees to comply with all applicable standards, orders or regulations issued pursuant to the Federal Water Pollution Control Act, as amended, 33 U.S.C. 1251 et seq.
- (2) The contractor agrees to report each violation to the (name of the state agency or local or Indian tribal government) and understands and agrees that the (name of the state agency or local or Indian tribal

government) will, in turn, report each violation as required to assure notification to the (name of recipient), Federal Emergency Management Agency, and the appropriate Environmental Protection Agency Regional Office.

(3) The contractor agrees to include these requirements in each subcontract exceeding \$150,000 financed in whole or in part with Federal assistance provided by FEMA.”

8. Debarment and Suspension.

- a. Applicability: This requirement applies to all FEMA grant and cooperative agreement programs.
- b. Non-federal entities and contractors are subject to the debarment and suspension regulations implementing Executive Order 12549, *Debarment and Suspension* (1986) and Executive Order 12689, *Debarment and Suspension* (1989) at 2 C.F.R. Part 180 and the Department of Homeland Security’s regulations at 2 C.F.R. Part 3000 (Nonprocurement Debarment and Suspension).
- c. These regulations restrict awards, subawards, and contracts with certain parties that are debarred, suspended, or otherwise excluded from or ineligible for participation in Federal assistance programs and activities. See 2 C.F.R. Part 200, Appendix II, ¶ H; and *Procurement Guidance for Recipients and Subrecipients Under 2 C.F.R. Part 200 (Uniform Rules): Supplement to the Public Assistance Procurement Disaster Assistance Team (PDAT) Field Manual* Chapter IV, ¶ 6.d, and Appendix C, ¶ 2 [hereinafter *PDAT Supplement*]. A contract award must not be made to parties listed in the SAM Exclusions. SAM Exclusions is the list maintained by the General Services Administration that contains the names of parties debarred, suspended, or otherwise excluded by agencies, as well as parties declared ineligible under statutory or regulatory authority other than Executive Order 12549. SAM exclusions can be accessed at www.sam.gov. See 2 C.F.R. § 180.530; *PDAT Supplement*, Chapter IV, ¶ 6.d and Appendix C, ¶ 2.
- d. In general, an “excluded” party cannot receive a Federal grant award or a contract within the meaning of a “covered transaction,” to include subawards and subcontracts. This includes parties that receive Federal funding indirectly, such as contractors to recipients and subrecipients. The key to the exclusion is whether there is a “covered transaction,” which is any nonprocurement transaction (unless excepted) at either a “primary” or “secondary” tier. Although “covered transactions” do not include contracts awarded by the Federal Government for purposes of the nonprocurement common rule and DHS’s implementing regulations, it does include some contracts awarded by recipients and subrecipient.
- e. Specifically, a covered transaction includes the following contracts for goods or services:

- (1) The contract is awarded by a recipient or subrecipient in the amount of at least \$25,000.
- (2) The contract requires the approval of FEMA, regardless of amount.
- (3) The contract is for federally-required audit services.
- (4) A subcontract is also a covered transaction if it is awarded by the contractor of a recipient or subrecipient and requires either the approval of FEMA or is in excess of \$25,000.

- d. The following provides a debarment and suspension clause. It incorporates an optional method of verifying that contractors are not excluded or disqualified:

“Suspension and Debarment

- (1) This contract is a covered transaction for purposes of 2 C.F.R. pt. 180 and 2 C.F.R. pt. 3000. As such the contractor is required to verify that none of the contractor, its principals (defined at 2 C.F.R. § 180.995), or its affiliates (defined at 2 C.F.R. § 180.905) are excluded (defined at 2 C.F.R. § 180.940) or disqualified (defined at 2 C.F.R. § 180.935).
- (2) The contractor must comply with 2 C.F.R. pt. 180, subpart C and 2 C.F.R. pt. 3000, subpart C and must include a requirement to comply with these regulations in any lower tier covered transaction it enters into.
- (3) This certification is a material representation of fact relied upon by (insert name of subrecipient). If it is later determined that the contractor did not comply with 2 C.F.R. pt. 180, subpart C and 2 C.F.R. pt. 3000, subpart C, in addition to remedies available to (name of state agency serving as recipient and name of subrecipient), the Federal Government may pursue available remedies, including but not limited to suspension and/or debarment.
- (4) The bidder or proposer agrees to comply with the requirements of 2 C.F.R. pt. 180, subpart C and 2 C.F.R. pt. 3000, subpart C while this offer is valid and throughout the period of any contract that may arise from this offer. The bidder or proposer further agrees to include a provision requiring such compliance in its lower tier covered transactions.”

9. Byrd Anti-Lobbying Amendment.

- a. Applicability: This requirement applies to all FEMA grant and cooperative agreement programs.
- b. Contractors that apply or bid for an award of \$100,000 or more must file the required certification. See 2 C.F.R. Part 200, Appendix II, ¶ I; 44 C.F.R. Part 18; *PDAT Supplement*, Chapter IV, 6.c; Appendix C, ¶ 4.
- c. Each tier certifies to the tier above that it will not and has not used Federal appropriated funds to pay any person or organization for influencing or

attempting to influence an officer or employee of any agency, a member of Congress, officer or employee of Congress, or an employee of a member of Congress in connection with obtaining any Federal contract, grant or any other award covered by 31 U.S.C. § 1352. Each tier must also disclose any lobbying with non-Federal funds that takes place in connection with obtaining any Federal award. Such disclosures are forwarded from tier to tier up to the non-Federal award. See PDAT Supplement, Chapter IV, ¶ 6.c and Appendix C, ¶ 4.

d. The following provides a Byrd Anti-Lobbying contract clause:

“Byrd Anti-Lobbying Amendment, 31 U.S.C. § 1352 (as amended)

Contractors who apply or bid for an award of \$100,000 or more shall file the required certification. Each tier certifies to the tier above that it will not and has not used Federal appropriated funds to pay any person or organization for influencing or attempting to influence an officer or employee of any agency, a member of Congress, officer or employee of Congress, or an employee of a member of Congress in connection with obtaining any Federal contract, grant, or any other award covered by 31 U.S.C. § 1352. Each tier shall also disclose any lobbying with non-Federal funds that takes place in connection with obtaining any Federal award. Such disclosures are forwarded from tier to tier up to the recipient.”

APPENDIX A, 44 C.F.R. PART 18 – CERTIFICATION REGARDING LOBBYING

Certification for Contracts, Grants, Loans, and Cooperative Agreements

(To be submitted with each bid or offer exceeding \$100,000)

The undersigned [Contractor] certifies, to the best of his or her knowledge, that:

1. No Federal appropriated funds have been paid or will be paid, by or on behalf of the undersigned, to any person for influencing or attempting to influence an officer or employee of an agency, a Member of Congress, an officer or employee of Congress, or an employee of a Member of Congress in connection with the awarding of any Federal contract, the making of any Federal grant, the making of any Federal loan, the entering into of any cooperative agreement, and the extension, continuation, renewal, amendment, or modification of any Federal contract, grant, loan, or cooperative agreement.
2. If any funds other than Federal appropriated funds have been paid or will be paid to any person for influencing or attempting to influence an officer or employee of any agency, a Member of Congress, an officer or employee of Congress, or an employee of a Member of Congress in connection with this Federal contract, grant, loan, or

cooperative agreement, the undersigned shall complete and submit Standard Form-LLL, "Disclosure Form to Report Lobbying," in accordance with its instructions.

3. The undersigned shall require that the language of this certification be included in the award documents for all subawards at all tiers (including subcontracts, subgrants, and contracts under grants, loans, and cooperative agreements) and that all subrecipients shall certify and disclose accordingly.

This certification is a material representation of fact upon which reliance was placed when this transaction was made or entered into. Submission of this certification is a prerequisite for making or entering into this transaction imposed by 31, U.S.C. § 1352 (as amended by the Lobbying Disclosure Act of 1995). Any person who fails to file the required certification shall be subject to a civil penalty of not less than \$10,000 and not more than \$100,000 for each such failure.

The Contractor, _____, certifies or affirms the truthfulness and accuracy of each statement of its certification and disclosure, if any. In addition, the Contractor understands and agrees that the provisions of 31 U.S.C. § 3801 *et seq.*, apply to this certification and disclosure, if any.

Signature of Contractor's Authorized Official

Name and Title of Contractor's Authorized Official

Date"

10. Procurement of Recovered Materials.

- a. Applicability: This requirement applies to all FEMA grant and cooperative agreement programs.
- b. A non-Federal entity that is a state agency or agency of a political subdivision of a state and its contractors must comply with Section 6002 of the Solid Waste Disposal Act, Pub. L. No. 89-272 (1965) (codified as amended by the Resource Conservation and Recovery Act at 42 U.S.C. § 6962). See 2 C.F.R. Part 200, Appendix II, ¶ J; 2 C.F.R. § 200.322; *PDAT Supplement*, Chapter V, ¶ 7.
- c. The requirements of Section 6002 include procuring only items designated in guidelines of the EPA at 40 C.F.R. Part 247 that contain the highest percentage of recovered materials practicable, consistent with maintaining a satisfactory level of

competition, where the purchase price of the item exceeds \$10,000 or the value of the quantity acquired by the preceding fiscal year exceeded \$10,000; procuring solid waste management services in a manner that maximizes energy and resource recovery; and establishing an affirmative procurement program for procurement of recovered materials identified in the EPA guidelines.

- d. The following provides the clause that a state agency or agency of a political subdivision of a state and its contractors can include in contracts meeting the above contract thresholds:

“(1) In the performance of this contract, the Contractor shall make maximum use of products containing recovered materials that are EPA-designated items unless the product cannot be acquired—

- (i) Competitively within a timeframe providing for compliance with the contract performance schedule;
- (ii) Meeting contract performance requirements; or
- (iii) At a reasonable price.

(2) Information about this requirement, along with the list of EPA-designate items, is available at EPA’s Comprehensive Procurement Guidelines web site, <https://www.epa.gov/smm/comprehensive-procurement-guideline-cpg-program>.”

11. Additional FEMA Requirements.

- a. The Uniform Rules authorize FEMA to require additional provisions for non-Federal entity contracts. FEMA, pursuant to this authority, requires or recommends the following:
- b. Changes.

To be eligible for FEMA assistance under the non-Federal entity’s FEMA grant or cooperative agreement, the cost of the change, modification, change order, or constructive change must be allowable, allocable, within the scope of its grant or cooperative agreement, and reasonable for the completion of project scope. FEMA recommends, therefore, that a non-Federal entity include a changes clause in its contract that describes how, if at all, changes can be made by either party to alter the method, price, or schedule of the work without breaching the contract. The language of the clause may differ depending on the nature of the contract and the end-item procured.

- c. Access to Records.

All non-Federal entities must place into their contracts a provision that all contractors and their successors, transferees, assignees, and subcontractors acknowledge and

agree to comply with applicable provisions governing Department and FEMA access to records, accounts, documents, information, facilities, and staff. See DHS Standard Terms and Conditions, v 3.0, ¶ XXVI (2013).

d. The following provides a contract clause regarding access to records:

“Access to Records. The following access to records requirements apply to this contract:

(1) The contractor agrees to provide (insert name of state agency or local or Indian tribal government), (insert name of recipient), the FEMA Administrator, the Comptroller General of the United States, or any of their authorized representatives access to any books, documents, papers, and records of the Contractor which are directly pertinent to this contract for the purposes of making audits, examinations, excerpts, and transcriptions.

(2) The Contractor agrees to permit any of the foregoing parties to reproduce by any means whatsoever or to copy excerpts and transcriptions as reasonably needed.

(3) The contractor agrees to provide the FEMA Administrator or his authorized representatives access to construction or other work sites pertaining to the work being completed under the contract.”

12. DHS Seal, Logo, and Flags.

- a. All non-Federal entities must place in their contracts a provision that a contractor shall not use the DHS seal(s), logos, crests, or reproductions of flags or likenesses of DHS agency officials without specific FEMA pre-approval. See DHS Standard Terms and Conditions, v 3.0, ¶ XXV (2013).
- b. The following provides a contract clause regarding DHS Seal, Logo, and Flags: “The contractor shall not use the DHS seal(s), logos, crests, or reproductions of flags or likenesses of DHS agency officials without specific FEMA pre-approval.”

13. Compliance with Federal Law, Regulations, and Executive Orders.

- a. All non-Federal entities must place into their contracts an acknowledgement that FEMA financial assistance will be used to fund the contract along with the requirement that the contractor will comply with all applicable federal law, regulations, executive orders, and FEMA policies, procedures, and directives.
- b. The following provides a contract clause regarding Compliance with Federal Law, Regulations, and Executive Orders: “This is an acknowledgement that FEMA financial assistance will be used to fund the contract only. The contractor

will comply with all applicable federal law, regulations, executive orders, FEMA policies, procedures, and directives.”

14. No Obligation by Federal Government.

- a. The non-Federal entity must include a provision in its contract that states that the Federal Government is not a party to the contract and is not subject to any obligations or liabilities to the non-Federal entity, contractor, or any other party pertaining to any matter resulting from the contract.
- b. The following provides a contract clause regarding no obligation by the Federal Government: “The Federal Government is not a party to this contract and is not subject to any obligations or liabilities to the non-Federal entity, contractor, or any other party pertaining to any matter resulting from the contract.”

15. Program Fraud and False or Fraudulent Statements or Related Acts.

- a. The non-Federal entity must include a provision in its contract that the contractor acknowledges that 31 U.S.C. Chap. 38 (Administrative Remedies for False Claims and Statements) applies to its actions pertaining to the contract.
- b. The following provides a contract clause regarding Fraud and False or Fraudulent or Related Acts: “The contractor acknowledges that 31 U.S.C. Chap. 38 (Administrative Remedies for False Claims and Statements) applies to the contractor’s actions pertaining to this contract.”