



# Elevator Installation

for Buildings Located in Special Flood Hazard Areas  
in Accordance with the National Flood Insurance Program

*NFIP Technical Bulletin 4 / June 2019*



**FEMA**

Comments on the Technical Bulletins should be directed to:

DHS/FEMA

Federal Insurance and Mitigation Administration (FIMA) Risk Management Directorate

Building Science Branch

400 C Street, S.W., Sixth Floor

Washington, DC 20472-3020

NFIP Technical Bulletin 4 (2019) replaces NFIP Technical Bulletin 4 (2010) *Elevator Installation for Buildings Located in Special Flood Hazard Areas in accordance with the National Flood Insurance Program*.

Cover photograph: Looking down on a traction elevator system that sustained damage, including rusting and cab deterioration, from contact with floodwater.

NFIP Technical Bulletin 4 contains information that is proprietary to and copyrighted by the American Society of Civil Engineers and information that is proprietary to and copyrighted by the International Code Council, Inc. All information is used with permission.

For more information, see the FEMA Building Science Frequently Asked Questions website at <http://www.fema.gov/frequently-asked-questions-building-science>.

If you have any additional questions on FEMA Building Science Publications, contact the helpline at [FEMA-Buildingsciencehelp@fema.dhs.gov](mailto:FEMA-Buildingsciencehelp@fema.dhs.gov) or 866-927-2104.

You may also sign up for the FEMA Building Science email subscription, which is updated with publication releases and FEMA Building Science activities. Subscribe at [https://service.govdelivery.com/accounts/USDHSFEMA/subscriber/new?topic\\_id=USDHSFEMA\\_193](https://service.govdelivery.com/accounts/USDHSFEMA/subscriber/new?topic_id=USDHSFEMA_193).

Visit the Building Science Branch of the Risk Management Directorate at FEMA's Federal Insurance and Mitigation Administration at <https://www.fema.gov/building-science>.

To order publications, contact the FEMA Distribution Center:

Call: 1-800-480-2520

(Monday–Friday, 8 a.m.–5 p.m., EST)

Fax: 719-948-9724

Email: [FEMApubs@gpo.gov](mailto:FEMApubs@gpo.gov)

Additional FEMA documents can be found in the FEMA Library at <https://www.fema.gov/media-library/resources>.

Please scan this QR code to visit the FEMA Building Science web page.



# Table of Contents

---

<b>Acronyms</b> .....	ii
<b>1 Introduction</b> .....	1
<b>2 NFIP Regulations</b> .....	1
<b>3 Other Regulations</b> .....	3
3.1 International Residential Code .....	3
3.2 International Building Code and ASCE 24.....	4
<b>4 How Elevators Affect NFIP Flood Insurance Rates</b> .....	5
4.1 Elevator Shafts/Enclosures.....	5
4.2 Elevator Cabs and Equipment.....	6
<b>5 Types of Elevators</b> .....	7
5.1 Hydraulic Elevators .....	7
5.2 Traction Elevators .....	8
5.3 Other Conveyance Mechanisms .....	10
<b>6 Protecting Elevators from Flood Damage</b> .....	11
6.1 Elevator Shafts/Enclosures.....	11
6.2 Elevator Equipment.....	12
6.3 Fire Recall Switches and Backup Power.....	13
6.4 Hydraulic Elevators .....	14
6.5 Traction Elevators .....	14
6.6 Other Conveyance Mechanisms.....	14
6.7 Mitigation Guidance Based on Post-Disaster Observations .....	14
<b>7 References</b> .....	16
<b>List of Figures</b>	
Figure 1. Direct-acting (holed) hydraulic elevator .....	8
Figure 2. Holeless hydraulic elevator .....	8
Figure 3. Traction elevator .....	9
Figure 4. Machine room-less traction elevator.....	9
Figure 5. Float switch to control cab descent .....	13

## List of Tables

Table 1.	Comparison of Select 2018 IRC and NFIP Requirements.....	3
Table 2.	Comparison of Select 2018 IBC and ASCE 24-14 Requirements with NFIP Requirements.....	4
Table 3.	Hydraulic Elevator System Components, Locations, and Flood-Protection Strategies.....	7
Table 4.	Traction Elevator System Components, Locations, and Flood Protection Strategies .....	10
Table 5.	General Guidance .....	15
Table 6.	Guidance for Specific Components .....	15

# Acronyms

---

ANSI	American National Standards Institute
ASCE	American Society of Civil Engineers
ASME	American Society of Mechanical Engineers
BFE	base flood elevation
CFR	Code of Federal Regulations
DHS	Department of Homeland Security
FEMA	Federal Emergency Management Agency
FIMA	Federal Insurance and Mitigation Administration
FIRM	Flood Insurance Rate Map
IBC	International Building Code®
ICC	International Code Council®
I-Codes	International Codes®
IRC	International Residential Code®
NEMA	National Electrical Manufacturers Association
NFIP	National Flood Insurance Program
NFPA	National Fire Protection Association
SEI	Structural Engineering Institute
SFHA	Special Flood Hazard Area
SFIP	Standard Flood Insurance Policy

# 1 Introduction

---

This Technical Bulletin provides guidance on the National Flood Insurance Program (NFIP) floodplain management requirements for installing elevators and associated equipment below the base flood elevation (BFE) in Special Flood Hazard Areas (SFHAs). This Technical Bulletin also discusses how the presence of elevators in buildings can affect flood insurance premiums.

Types of elevators and associated equipment are described, along with practical methods of protecting elevators from flood damage. Even when compliance is not required, application of these loss prevention measures can reduce the level of damage that can occur, the resultant repair costs, and the time elevators are out of service. If this guidance is followed, elevator service in buildings can be restored as quickly as possible once floodwater recedes and power is restored.

Questions about the NFIP floodplain management requirements pertaining to elevators should be directed to the appropriate local official, NFIP State Coordinating Office, or FEMA Regional Office.

## NFIP TECHNICAL BULLETIN 0

NFIP Technical Bulletin 0, *User's Guide to Technical Bulletins*, should be used as a reference in conjunction with this Technical Bulletin. Technical Bulletin 0 describes the purpose and use of the Technical Bulletins, includes common concepts and terms, lists useful resources, and includes a crosswalk of the sections of the NFIP regulations identifying the Technical Bulletin that addresses each section of the regulations and a subject index.

Readers are cautioned that the definition of some of the terms that are used in the Technical Bulletins are not the same when used by the NFIP for the purpose of rating flood insurance policies.

# 2 NFIP Regulations

---

An important NFIP objective is protecting buildings constructed in SFHAs from damage caused by flood forces. The SFHA, composed of Zones A and V, is the areal extent of the base flood shown on Flood Insurance Rate Maps (FIRMs) prepared by FEMA. The base flood is the flood that has a 1 percent chance of being equaled or exceeded in any given year (commonly called the “100-year flood”).

The NFIP floodplain management regulations include minimum building design criteria that apply to new construction and to improvements, alterations, and additions determined to be Substantial Improvements. The minimum criteria also apply to the repair of buildings determined to have incurred Substantial Damage. The NFIP regulations require the lowest floor (including basement) to be elevated to or above the BFE in new construction and for improvements determined to be Substantial Improvements (including repair of

## INCREASED USE OF ELEVATORS

Elevators have become more common in residential and nonresidential construction to facilitate access because of the requirements to elevate buildings and comply with the Americans with Disabilities Act of 1990.



buildings determined to have incurred Substantial Damage). Non-residential buildings in Zone A must be elevated or dry floodproofed.

The NFIP regulations for utility systems, including elevator equipment, are codified in Title 44 of the Code of Federal Regulations (CFR) Part 60. Pertaining specifically to this Technical Bulletin, 44 CFR Section 60.3(a)(3) states that a community shall:

Review all permit applications to determine whether proposed building sites will be reasonably safe from flooding. If a proposed building site is in a flood-prone area, all new construction and substantial improvements shall ... (ii) be constructed with materials resistant to flood damage, (iii) be constructed by methods and practices that minimize flood damages, and (iv) be constructed with electrical, heating, ventilation, plumbing, and air conditioning equipment and other service facilities that are designed and/or located so as to prevent water from entering or accumulating within the components during conditions of flooding.

To comply with the NFIP regulations, measures must be taken to mitigate flood damage to service facilities, including elevators and associated equipment. Although in order to function, some components must be located below the lowest floor of an elevated building (i.e., below the BFE), most of the elevator components that are vulnerable to flooding can be located above the BFE or be designed so that flood damage is minimized.

#### NFIP REQUIREMENTS AND HIGHER REGULATORY STANDARDS

**State and Local Requirements.** State or local requirements that are more stringent than the minimum requirements of the NFIP take precedence. The Technical Bulletins and other FEMA publications provide guidance on the minimum requirements of the NFIP and describe best practices. Design professionals, builders, and property owners should contact local officials to determine whether more restrictive provisions apply to buildings or sites in question. All other applicable requirements of the State or local building codes must also be met for buildings in flood hazard areas.

**Substantial Improvement and Substantial Damage.** As part of issuing permits, local officials must review not only proposals for new construction but also for work on existing buildings to determine whether the work constitutes Substantial Improvement or repair of Substantial Damage. If the work is determined to constitute Substantial Improvement or repair of Substantial Damage, the buildings must be brought into compliance with NFIP requirements for new construction. Some communities modify the definitions of Substantial Improvements and/or Substantial Damage to be more restrictive than the NFIP minimum requirements. For more information on Substantial Improvement and Substantial Damage, see FEMA P-758, *Substantial Improvement/Substantial Damage Desk Reference* (2010), and FEMA 213, *Answers to Questions About Substantially Damaged/Substantially Damaged Buildings* (2018).

**Higher Building Elevation Requirements.** Some communities require that buildings be elevated above the NFIP minimum requirements. The additional elevation is called freeboard. Design professionals, builders, and property owners should check with local officials to determine whether a community has freeboard requirements. References to building elevations in this Technical Bulletin should be construed as references to the community's elevation requirement in areas where freeboard is required.

# 3 Other Regulations

In addition to complying with NFIP requirements, all new construction, Substantial Improvements, and repairs of Substantial Damage must comply with the applicable building codes and standards that have been adopted by States and communities.

The International Codes® (I-Codes®), published by the International Code Council® (ICC®) are a family of codes that include the International Residential Code® (IRC®), International Building Code® (IBC®), International Existing Building Code® (IEBC®), and codes that govern the installation of mechanical, plumbing, fuel gas service, and other aspects of building construction. FEMA has deemed that the latest published editions of the I-Codes meet or exceed NFIP requirements for buildings and structures. Excerpts of the flood provisions of the I-Codes are available on FEMA’s Building Code Resource webpage (<http://www.fema.gov/building-code-resources>).

## 3.1 International Residential Code

The IRC applies to one- and two-family dwellings and townhomes not more than three stories above grade plane. IRC Section R321 requires that elevators comply with ASME A17.1/CSA B44, *Safety Code for Elevators and Escalators* (2016). The 2018 IRC requirements related to building utility and service equipment in dwellings in SFHAs (summarized in Table 1) are similar to, but generally exceed, NFIP requirements.

**IRC COMMENTARY**

ICC publishes companion commentary for the IRC. Although not regulatory, the commentary provides guidance that is useful in complying with, interpreting, and enforcing the requirements of the code.

**Table 1. Comparison of Select 2018 IRC and NFIP Requirements**

Topic	Summary of Select 2018 IRC Requirements and Changes from 2015 and 2012 Editions	Comparison with NFIP Requirements
Mechanical, plumbing, and electrical systems	<p><b>Section R322.1.6 Protection of mechanical, plumbing and electrical systems.</b></p> <p>Specifies that protection of electrical systems, equipment, and components; heating, ventilating, air conditioning; plumbing appliances and plumbing fixtures; duct systems; and other service equipment should be located at or above the elevations required for buildings based on flood zone. In addition:</p> <ul style="list-style-type: none"> <li>• Equipment and components replaced as part of Substantial Improvement must meet the same requirements as new construction.</li> <li>• Systems, fixtures, equipment, and components must not be mounted on or penetrate through walls intended to break away under flood loads.</li> <li>• An exception allows equipment and components below the required elevation if designed and installed to prevent water from entering or accumulating within the components and to resist flood loads.</li> <li>• Electrical wiring systems that conform to requirements for wet locations are permitted below the required elevation.</li> </ul> <p><u>Change from 2015 to 2018 IRC:</u> No change.</p> <p><u>Change from 2012 to 2015 IRC:</u> No change.</p>	<p>Exceeds NFIP 44 CFR § 60.3(a)(3) with more specificity: Elevation must be to at least the same height as the elevation requirement for dwellings, and limitations related to breakaway walls, acknowledge that minimum electric service may be appropriate (e.g., for light switches).</p>

**Table 1. Comparison of Select 2018 IRC and NFIP Requirements (concluded)**

Topic	Summary of Select 2018 IRC Requirements and Changes from 2015 and 2012 Editions	Comparison with NFIP Requirements
General mechanical systems	<p><b>Section M1301.1.1 [General Mechanical System Requirements] Flood-resistant installation.</b></p> <p>Requires mechanical appliances, equipment, and systems to be located and installed in accordance with Section R322.1.6.</p> <p><u>Change from 2015 to 2018 IRC:</u> No change.</p> <p><u>Change from 2012 to 2015 IRC:</u> No change.</p>	Exceeds NFIP 44 CFR § 60.3(a) (3) with more specificity.

Used with permission from ICC.

## 3.2 International Building Code and ASCE 24

The flood provisions of the latest published editions of the IBC meet or exceed the NFIP requirements for buildings, largely through reference to the standard ASCE 24, *Flood Resistant Design and Construction*, developed by the American Society of Civil Engineers (ASCE). The IBC applies to all applicable buildings and structures. While primarily used for buildings and structures other than dwellings within the scope of the IRC, the IBC may be used to design dwellings. Current (2018) IBC and current ASCE 24 (ASCE 24-14 [2014]) requirements for buildings in SFHAs are summarized in Table 2.

### IBC AND ASCE COMMENTARIES

ICC publishes companion commentary for the IBC and ASCE publishes companion commentary for ASCE 24. Although not regulatory, the commentaries provide information and guidance that are useful in complying with, interpreting, and enforcing requirements.

**Table 2. Comparison of Select 2018 IBC and ASCE 24-14 Requirements with NFIP Requirements**

Topic	Summary of Select 2018 IBC/ASCE 24-14 Requirements and Changes from 2015 and 2012/ASCE 24-05	Comparison with NFIP Requirements
General flood hazard area requirements	<p><b>2018 IBC, Section 1612.2 Design and construction.</b></p> <p>Requires buildings and structures located in flood hazard areas to be designed and constructed in accordance with Chapter 5 of ASCE 7, <i>Minimum Design Loads and Associated Criteria for Buildings and Other Structures</i>, and ASCE 24.</p> <p><u>Change from 2015 to 2018 IBC:</u> Section renumbered from 1612.4 to 1612.2.</p> <p><u>Change from 2012 to 2015 IBC:</u> Applies Coastal High Hazard Area requirements in Coastal A Zones, if delineated.</p>	Exceeds NFIP 44 CFR § 60.3(a) (3) with more specificity.
Elevators	<p><b>2018 IBC, Chapter 30, Elevators and Conveying Systems, Section 3001.3 Referenced standards.</b></p> <p>Specifies the standards that govern the design, construction, installation, alteration, repair, and maintenance of elevators and conveying systems and components. Among other standards cited is ASME A17.1, <i>Safety Code for Elevators and Escalators</i>, issued by the American Society of Mechanical Engineers. ASCE 24 is cited for construction in flood hazard areas.</p> <p><u>Change from 2015 to 2018 IBC:</u> Section renumbered from 3001.2 to 3001.3 and referenced standards, other than ASCE 24, provided in Table 3001.3.</p> <p><u>Change from 2012 to 2015 IBC:</u> ASME A17.7/CSA B44.7 and ANSI MH29.1 added to Section 3001.2.</p>	Exceeds NFIP 44 CFR § 60.3(a) (3) with more specificity.



Table 2. Comparison of Select 2018 IBC and ASCE 24-14 Requirements with NFIP Requirements (concluded)

Topic	Summary of Select 2018 IBC/ASCE 24-14 Requirements and Changes from 2015 and 2012/ASCE 24-05	Comparison with NFIP Requirements
Elevators	<p><b>ASCE 24-14, Section 7.5 Elevators</b></p> <ul style="list-style-type: none"> <li>• Elevator components must be located above the elevations required for buildings unless specifically permitted by this section.</li> <li>• Components below the required elevations must be composed of flood damage-resistant materials and capable of resisting physical damage due to flooding.</li> <li>• Hydraulic elevators are permitted below the required elevation, but electrical control panels, hydraulic pumps, and tanks must be elevated; drainage must be provided for the elevator pit; hydraulic lines, hydraulic cylinders, and buffer springs must be located to prevent physical damage due to flooding or painted or coated with galvanic or rust-preventive paint.</li> <li>• Traction elevator systems must have elevated machine rooms, and components in hoistways below the required elevation must be protected from physical damage due to flooding.</li> <li>• Elevators must be equipped with controls that prevent cabs from descending into floodwater.</li> <li>• Elevator shafts must resist flood loads. In Zone A, shafts are not required to have flood openings; in Zone V and Coastal A Zones, shafts are not required to have breakaway walls.</li> </ul> <p><u>Change from ASCE 24-05:</u> Added subsection on elevator shafts.</p>	Exceeds NFIP 44 CFR § 60.3(a) (3) with more specificity.

Used with permission from ASCE and ICC

## 4 How Elevators Affect NFIP Flood Insurance Rates

NFIP floodplain management regulations restrict use of enclosed areas below the lowest elevated floor of elevated buildings to parking of vehicles, building access, and storage. Elevators, just as stairs and ramps, are permitted for building access. Although elevators and elevator shafts/enclosures are covered by NFIP flood insurance policies, their presence in a building, their size, and their manner of construction are factors used by insurance underwriters to determine a building’s flood insurance premium.

### 4.1 Elevator Shafts/Enclosures

For buildings located in Zone A (all zones shown on FIRMs as Zones A, AE, A1 through A30, AR, AO, and AH), where elevator shafts/enclosures are not designed to automatically equalize hydrostatic flood forces on its exterior walls, a premium loading is added to the standard flood insurance building rate. The amount of premium loading depends on the square footage of the elevator shaft/enclosure and the depth of the shaft/enclosure in relation to the BFE. However, no premium loading is added to the standard building rate if the elevator shaft/enclosure is designed to automatically equalize hydrostatic flood forces on exterior walls by allowing the entry and exit of floodwater, is unfinished, and used only for building access, parking of vehicles, or storage.

## FLOOD INSURANCE TERMINOLOGY AND RATING OF ELEVATOR PITS

The NFIP and Standard Flood Insurance Policy (SFIP) define a **basement** as “any area of the building, including any sunken room or sunken portion of a room, having its floor below ground level (subgrade) on all sides.” Additionally, the NFIP and SFIP define the **lowest floor** as “the lowest enclosed area (including a basement). An unfinished or flood-resistant enclosure, usable solely for parking of vehicles, building access, or storage in an area other than a basement area, is not considered a building’s lowest floor provided that such enclosure is not built so as to render the structure in violation of requirements.” The SFIP defines an **elevated building** as “a building that has no basement and that has its lowest floor raised above ground level by foundation walls, posts, piers, pilings, or columns.”

**Elevator Pits.** A building that has its lowest elevated floor raised above ground level by foundation walls, posts, piers, pilings, or columns where the only area below grade is an elevator pit is classified as an elevated building for insurance rating purposes, even if the bottom of the elevator pit is below grade on all sides. There is a premium surcharge for elevators in an SFHA if the elevator pit is below the BFE, whether the pit is below grade or not. For non-elevated buildings with any area below grade, including an elevator pit, the below-grade portions are classified as basements for flood insurance rating purposes. Floodplain management regulations do not consider elevator pits that are the minimum size necessary as to be basements if they are designed in accordance with the requirements of this Technical Bulletin (i.e., the elevator pit is the minimum size required for the elevator to function, has no finishes, and contains no equipment).

For buildings located in Zone V (all zones shown on FIRMs as Zone V, VE, and V1 through V30), elevator shafts/enclosures with walls surrounding the elevator cab are always considered building obstructions. If the elevator shaft/enclosure exceeds 300 square feet and has breakaway walls, then a premium loading factor is added to the overall flood insurance building rate with obstruction. The amount of the premium loading depends on the actual square footage of the elevator shaft/enclosure, and the depth of the shaft/enclosure in relation to the BFE. However, no premium loading is added to the standard building with obstruction rate if the elevator shaft/enclosure is less than 300 square feet, made with breakaway walls, is unfinished, and used only for building access, parking of vehicles, or storage.

## 4.2 Elevator Cabs and Equipment

The NFIP provides coverage for elevator cabs and their related equipment as building property. However, the NFIP does not cover elevator-related equipment located below the lowest floor of elevated buildings constructed after the community joined the NFIP or installed below the BFE after September 30, 1987. A separate premium loading is added to the cab and any permanent machinery and equipment servicing an elevator in a building that extends below the BFE in Zone A or Zone V.

# 5 Types of Elevators

Elevators are vertical transports that move people or materials between the floors or levels of a structure. All elevators have a cab or platform in a shaft; the cab or platform moves along rails and is powered by one or more motors. Some of the differences between elevator systems are related to how the cab or platform is transported between levels.

**ASME A17.1 TERMINOLOGY**

For consistency with ASME A17.1, the industry standard, this Technical Bulletin refers to elevators as residential and commercial.

The two primary types of elevators used in residential and commercial buildings are hydraulic elevators and traction elevators. A key difference between them is that hydraulic elevators lift the elevator cab using one or more pistons while traction elevators lift the elevator cab using steel cables and a traction motor.

Other conveyance systems include pneumatic elevators, chairlifts, and platform lifts.

## 5.1 Hydraulic Elevators

A hydraulic elevator consists of a cab attached directly or indirectly to a hydraulic jack that consists of a direct-acting piston inside a cylinder. Hydraulic elevators can be direct-acting (holed) or holeless. In direct-acting hydraulic elevators, the hydraulic jack assembly extends below the lowest floor and into the ground below the pit area (Figure 1). In contrast, for holeless hydraulic elevators, cylinders are placed in the shaft sides and do not extend below the pit floor (Figure 2). Both types of hydraulic elevators are operated by a hydraulic pump and reservoir for hydraulic fluid, both of which are usually located in a room adjacent to the elevator shaft. Both types of hydraulic elevators are generally used in buildings with fewer than five or six floors, including dwellings.

Table 3 provides a summary of hydraulic elevator system components, their typical location, and strategies to protect them from flood damage.

**Table 3. Hydraulic Elevator System Components, Locations, and Flood-Protection Strategies**

Elevator Component	Typical Component Location	Flood Protection Strategy	
		Elevation Above BFE	Flood Damage-Resistant Component
Elevator Shaft (Enclosure)	Entire vertical limit of building	No	Yes Below the BFE
Cab	Hoistway	Yes	Yes
Cylinder	Pit	No	No Use holeless (see Table 5)
Hydraulic Jack Assembly	Pit	No	No Use holeless (see Table 5)
Buffer Springs and Stand	Pit	No	No Paint or coat (see Table 6)
Machine/Equipment Room	1st or 2nd level of building	Yes	Yes
Hydraulic Pump	Above BFE	Yes	Yes
Hydraulic Reservoir	Above BFE	Yes	Yes
Electrical Control Panel	Above BFE	Yes	No

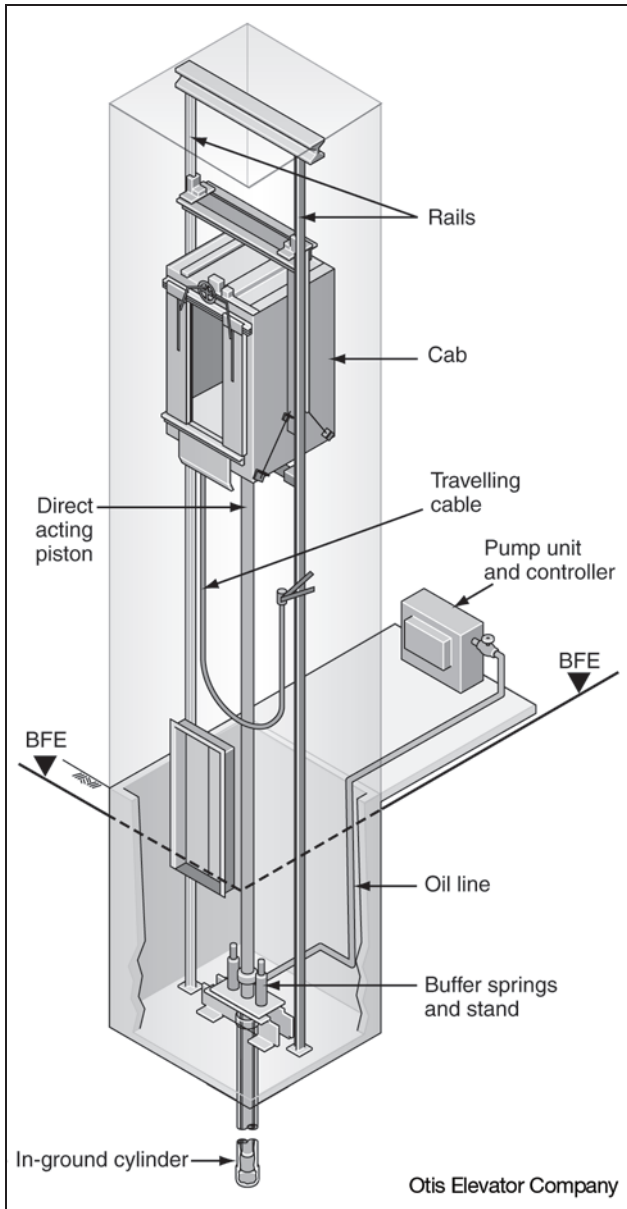

Figure 1. Direct-acting (holed) hydraulic elevator

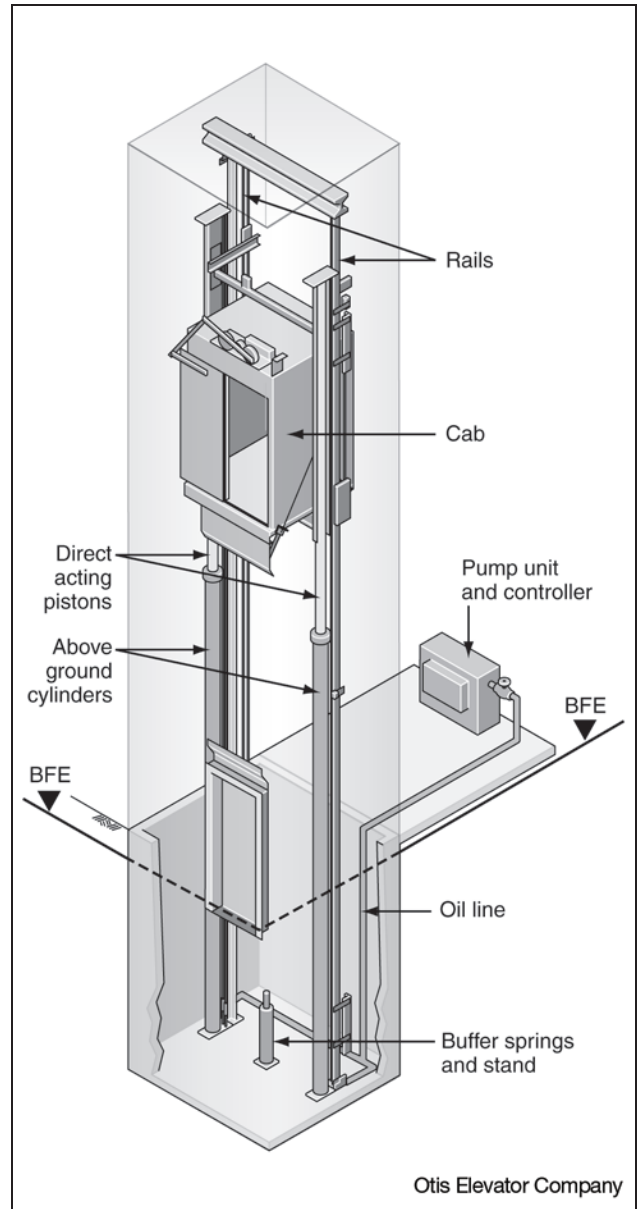

Figure 2. Holeless hydraulic elevator

## 5.2 Traction Elevators

Traditional geared traction elevator systems consist of cables connected to the top of the cab operated by an electric motor located in a penthouse above the elevator shaft, as shown in Figure 3. Traction elevators may be geared or gearless depending on building height, speed requirements, and cost considerations. Geared traction elevators are typically used for small low-rise structures, while more expensive gearless traction elevators tend to be used for larger high-rise structures, where speed is

### LOW-RISE AND HIGH-RISE

For purposes of this Technical Bulletin, “low-rise” refers to dwellings within the scope of the IRC (one- and two-family homes and townhomes not more than three stories above grade plane) and other structures with a mean roof height of less than 75 feet. “High-rise” refers to structures with a mean roof height of 75 feet or more.

more critical. Machine room-less traction elevators employ a similar mechanical arrangement to geared traction elevators, with the machinery located in the elevator shaft at the top of the hoistway, as shown in Figure 4. Traction elevators are generally used in tall buildings.

Table 4 provides a summary of traction elevator system components, their typical location, and strategies to protect them from flood damage. Note that while nearly all traction elevator system components can be protected from flood damage, little can be done to protect governor cables, which typically must be replaced after flooding.

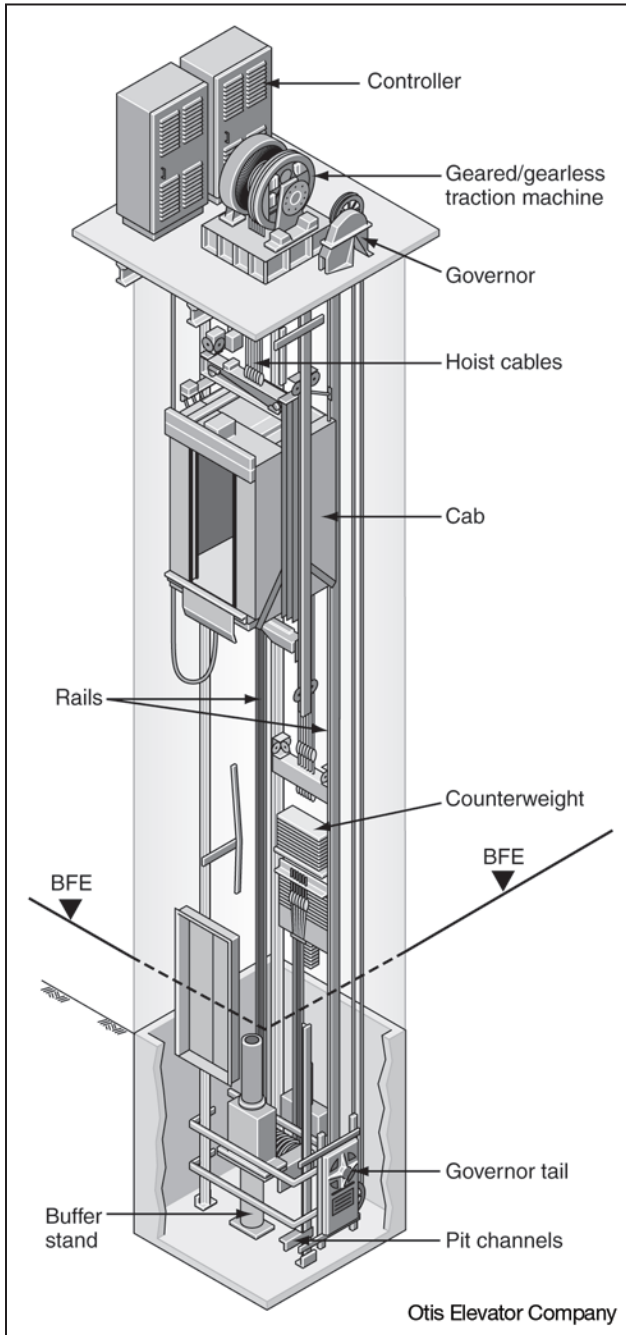

Figure 3. Traction elevator

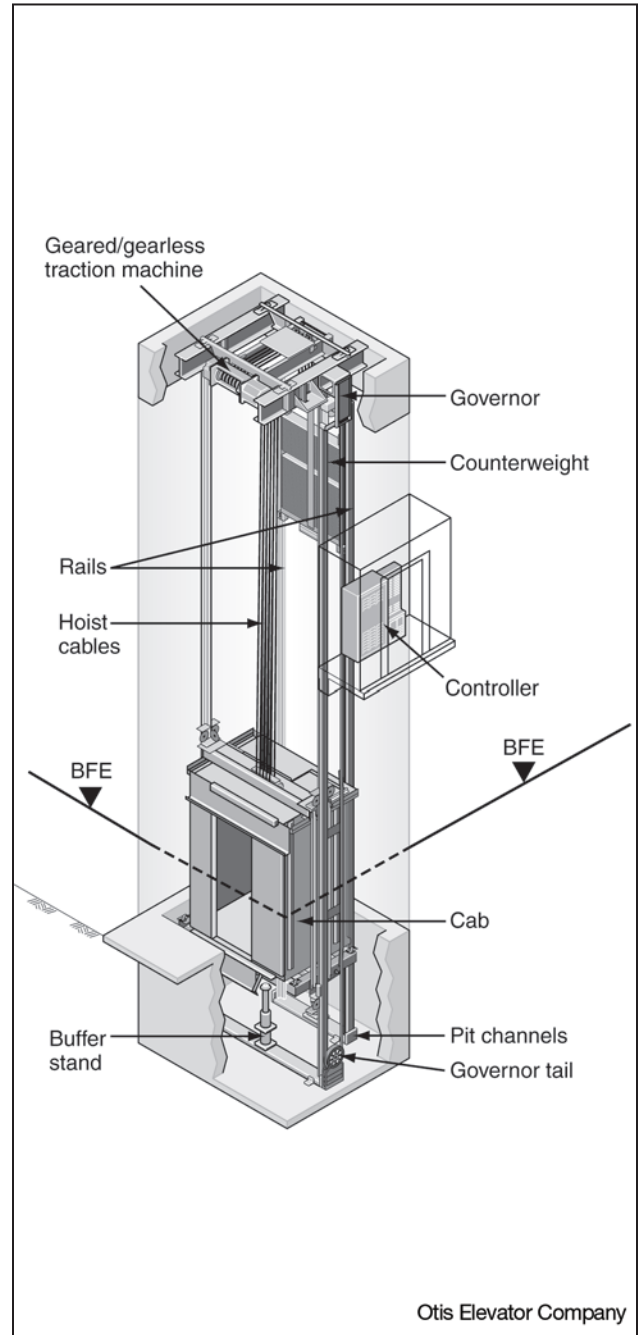

Figure 4. Machine room-less traction elevator



**Table 4. Traction Elevator System Components, Locations, and Flood Protection Strategies**

Elevator Component	Typical Component Location	Flood Protection Strategy	
		Elevation Above BFE	Flood Damage-Resistant Component
Elevator Shaft (Enclosure)	Entire vertical limit of building	No	Yes Below the BFE
Cab	Hoistway	Yes	No
Counterweight and Roller Guides	Hoistway	Yes	No
Hoist Cable	Hoistway	Yes	No
Compensation Cables	Pit	No	Yes
Governor Cable	Pit	No	No
Buffers	Pit	No	No Paint or coat (see Table 6)
Limit Switches	Pit	Yes	No
Machine/Equipment Room (Enclosure)	Top of hoistway	Yes	No Replace with machine room-less
Electric Hoist Motor	Above BFE	Yes	No
Electrical Control Panel	Above BFE	Yes	No

### 5.3 Other Conveyance Mechanisms

In addition to hydraulic and traction elevators, other conveyance systems used include pneumatic elevators, chairlifts, and platform lifts.

Pneumatic elevators are small elevators with cabs controlled by a roof-mounted suction system. Pneumatic elevators are generally found in smaller buildings such as residences; they are not widely used in larger buildings because the cabs tend to be small. Other elevator types are roped hydraulic elevators and cable drum elevators, which are similar in function to the primary elevator types described in Sections 5.1 and 5.2.

Chairlifts are conveyance mechanisms installed over or alongside a stairway to transport occupants between floors. Chairlifts are designed to operate both inside and outside of structures, while residential elevators are commonly placed inside if designed from the start, and outside the main structure footprint if the elevator is part of a renovation.

Platform lifts are designed to transport an individual in a wheelchair from one level to another. They are usually designed so that a wheelchair user can enter the lift on one side and exit on another (i.e., the lift has two doors).

#### ASCE 24 AND ELEVATORS

This section is based in part on the requirements of ASCE 24-14, Section 7.5, and the commentary that accompanies that section.

# 6 Protecting Elevators from Flood Damage

This section describes measures to protect elevator components and equipment that are common to all elevator systems from flood damage, and specific guidance to protect hydraulic and traction elevators in accordance with NFIP regulations.

## 6.1 Elevator Shafts/Enclosures

Elevator shafts enclose the elevator cab and other equipment. Residential and commercial elevators, particularly those that are added as a post-construction retrofit, are usually installed in a shaft that is exterior to an original outside wall. Larger elevators are installed in shafts located in the interior of structures. In either case, elevator shafts must have landings, usually at the ground level, and cab platforms near the top of the shaft. Elevators that have a landing at the lower level almost always have pits below the BFE. Requirements for electrical service for sump pumps in elevator pits can be found in NFPA 70, *National Electrical Code* (2017).

The NFIP requires enclosed areas below elevated buildings in Zone A to have flood openings to minimize unequal hydrostatic loads (see NFIP Technical Bulletin 1, *Openings in Foundation Walls and Walls of Enclosures Below Elevated Buildings in Special Flood Hazard Areas*) and that walls that form enclosures below elevated buildings in Zone V be designed to break away under flood loads. However, elevator shafts/enclosures that extend below the BFE are not required to include flood openings if the openings conflict with fire safety protection requirements in building codes. Even with breakaway walls, elevators extending below the BFE may be obstructions to the free passage of waves and water. Without openings or breakaway walls, the shafts/enclosures may obstruct the flow of floodwater, impose more loads on building foundations, and are susceptible to damage from various flood forces, including erosion and scour.

To minimize flood damage, elevator shafts/enclosures must be designed to resist hydrostatic, hydrodynamic, and debris impact forces, as well as erosion, scour, and waves, particularly in Zone V. To reduce exposure of elevators to flood loads, a common practice is to construct reinforced masonry block or reinforced concrete elevator shafts and locate them on the landward side of buildings in coastal areas and on the downstream side of buildings in riverine floodplains. Furthermore, designs for nearby or adjacent structural elements of the building should take into account the impacts of obstructed flow.

### ASCE 24: FLOOD OPENINGS IN BREAKAWAY WALLS AND ELEVATOR SHAFTS

ASCE 24-14 clarifies that flood openings are not required in elevator shafts, and in Coastal High Hazard Areas and Coastal A Zones, elevator shafts are not required to have breakaway walls.

### ELEVATOR PITS

Although the NFIP defines a basement as any area below grade on all sides, elevator pits that are the minimum size necessary for the elevator to function are not considered to be basements. Elevator pits typically range between 4 and 5 feet deep for hydraulic elevators and between 6 and 8 feet deep for traction elevators. Additional information is contained in Section 4.

## 6.2 Elevator Equipment

Some equipment common to all elevators that extend below the BFE will be exposed to floodwater. The most obvious vulnerable component is the elevator cab. Depending on the size of the cab and the types of interior materials used, residential and commercial elevator cabs can be expensive to replace.

Flood damage-resistant materials can be used inside and outside the elevator cab to reduce flood damage (see NFIP Technical Bulletin 2, *Flood Damage-Resistant Materials Requirements for Buildings Located in Special Flood Hazard Areas*).

**Cabs:** Flood damage to cabs, which can range from superficial to significant, can be avoided by keeping cabs above floodwater when not in use. However, most elevator control systems automatically stop cabs upon loss of electrical power, which could result in a cab stopping below the BFE, making it vulnerable during flooding.

**Float switches:** Installing detection systems with one or more float switches in elevator shafts will prevent elevator cabs from descending into floodwater (Figure 5), providing a safer system while minimizing costly repairs or replacement. A float switch system or another system that provides the same level of safety is required, per ASME A17.1, for all elevators where there is a potential for the elevator cab to descend below the BFE during flood conditions.

**Elevator equipment:** Elevator equipment such as electrical controls and hydraulic pumps should be located above the BFE when possible. In some installations, it may be necessary to locate elevator equipment such as switches and controls below the BFE in the elevator pit. Some electrical equipment, such as electrical junction boxes and circuit and control panels, must be located at or above the elevation required for the building. Other elevator components, such as doors and pit switches, may be below that elevation. In these cases, damage can be minimized by using flood damage-resistant components or placing gear in water-resistant enclosures to reduce damage from floodwater.

**Electrical equipment:** Any electrical equipment installed in the hoistway below the BFE should be inside a National Electrical Manufacturers Association (NEMA) 4-rated enclosure for water resistance. Some elevator equipment manufacturers offer water-resistant components. Therefore, design professionals should contact suppliers to determine the availability of these components.

All elevator equipment and components should be maintained and tested in accordance with the manufacturer's requirements and maintenance schedules. This is especially true for safety components

### ASCE 24 AND EQUIPMENT

ASCE 24 requires electrical control panels, hydraulic pumps, and tanks to be located above the elevation required for buildings. ASCE 24 also requires drainage for elevator pits.

### ELEVATOR EQUIPMENT AND CORROSION IN COASTAL AREAS

In coastal areas, building equipment, connectors, and other metal parts are regularly corroded by air-borne salts. Some protection for elevator equipment can be provided by constructing a small foyer to enclose the area around the elevator door. The NFIP has requirements for such enclosures that are based on whether the flood zone is Zone A or Zone V. See Technical Bulletin 8, *Corrosion Protection for Metal Connectors and Fasteners in Coastal Areas*, for additional information on corrosion in coastal areas.

such as high-water sensors and switches and their associated alarms. If these elements are found to be inoperative or out of specified tolerances, the elevator should be repaired by a qualified technician.

### 6.3 Fire Recall Switches and Backup Power

For safety reasons, commercial elevators are designed with “fire recall” circuitry, which sends elevators to a designated floor when fire alarms are activated so that emergency services personnel can use the elevators. However, during flooding, this feature may expose the cab and occupants directly to floodwater. ASME A17.1 requires that, for elevators in SFHAs, the designated floor must be located above the BFE. If an elevator is intended to serve areas that may be flooded, it should be equipped with a float switch system that will activate during flooding and send the elevator cab to a floor above the BFE (Figure 5).

Emergency power circuitry is provided for elevators when buildings have emergency generators. In general, when emergency power starts up, all elevator cars return to the designated floor, and then one car returns to normal operation. Emergency power generators are required for elevators in buildings of four or more stories but are not commonly found in low-rise buildings. If there is no emergency power, some hydraulic elevators can employ a battery descent feature. Upon power loss, batteries release the hydraulic controls, and the car descends to the lowest landing. If this feature is employed, care should be taken to integrate a float switch system into the operation of the controller to prevent the car from descending into floodwater.

If elevators have no emergency power operation or battery descent feature, upon loss of power the elevators will cease to function, resulting in possible entrapment or damage. Therefore, building owners should have emergency plans that provide for safe occupant evacuations, having elevator cabs move to upper floors (above the BFE) and shutting down power to the elevator machinery well before any flooding occurs.

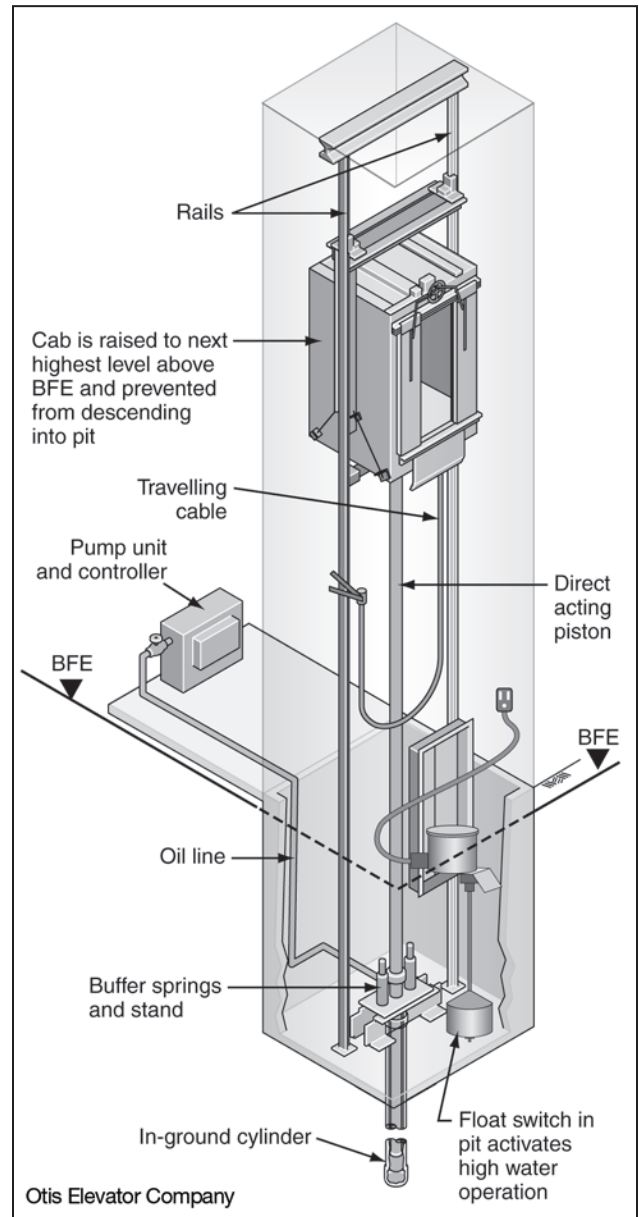

Figure 5. Float switch to control cab descent

## 6.4 Hydraulic Elevators

The hydraulic jack assembly for a direct-acting (holed) hydraulic elevator (Figure 1) will, by necessity, be located below the lowest floor and, therefore, likely below the BFE. The jack is located in a casing that can resist damage from small amounts of water seepage, although corrosive saline water is particularly damaging. However, total inundation by floodwater will usually result in contamination of the hydraulic fluid and possible damage to jack cylinders and seals. For this reason, holeless hydraulic elevators are recommended for low-rise buildings.

When hydraulic elevators are used, jacks should be installed inside the elevator shaft, with critical seals and components located above BFE as shown in Figure 2. Hydraulic pumps and fluid reservoirs should be located above the BFE. In addition, hydraulic lines connecting the assembly should be located where the lines are protected from physical damage or coated with galvanic or rust-preventive paint. Additional guidance based on post-disaster observations is included in Section 6.7.

## 6.5 Traction Elevators

Electric motors and most other traction elevator equipment used for traction elevators are normally located above the elevator shaft and are, therefore, not usually susceptible to flood damage (Figure 5). However, some equipment such as the counterweight roller guides, compensation cable assemblies, limit switches, selector tape, governor rope assemblies, and oil buffers are usually located at the bottom of the shaft. When these components cannot be located above the BFE, they must be constructed of flood damage-resistant materials where possible. Additional guidance based on post-disaster observations is included in Section 6.7.

While nearly all traction elevator system components can be protected from flood damage, little can be done to protect governor tail cables, which typically must be replaced after flooding.

## 6.6 Other Conveyance Mechanisms

Pneumatic elevators, chairlifts, and platform lifts are usually located inside buildings where the components of these systems can be located above the BFE to protect them from flood damage. However, when platform lifts are installed outdoors, it can be more difficult to elevate equipment above the BFE, making it susceptible to flood damage.

## 6.7 Mitigation Guidance Based on Post-Disaster Observations

The following guidance is based on observations made following Hurricane Katrina (2005), Hurricane Ike (2008), and Hurricane Sandy (2013). Some recommendations could apply to new installations, and some apply when building owners and managers consider retrofitting and replacing existing elevator systems.



**Table 5. General Guidance**

Topic	General Guidance	Comments
Holeless Hydraulics	For hydraulic elevators, explore hoistway conditions for the use of holeless hydraulics. Note that holeless hydraulic elevators are typically used in low-rise construction with only two or three floors.	—
Raised Elevators	In an effort to maintain the operational capacity of critical facilities with multiple elevators during flood events, consider installing one or more raised elevators with no components or floor stops below the BFE. Ramps can be provided to access the higher elevation. This will allow some of the building’s vertical transportation systems to be isolated above the BFE, helping to ensure some access to upper levels. While FEMA recommends that people evacuate when authorities at State and local levels advise or mandate it, emergencies and disasters can create circumstances that require robust elevator systems to be operational before, during, and after flood events, such as with approved shelter-in-place plans.	—
Increased Resilience	Consider raising elevator mechanical, electrical, and other equipment vital to operations to levels above the BFE to reduce exposure when flooding is more severe than the base flood.	Refer to FEMA P-942, <i>Recovery Advisory 4, Reducing Interruptions to Mid- and High-Rise Buildings During Floods</i> , for details (2013)
Continuity of Operations	Consider sizing emergency generator capacity to enable critical elevator operations in accordance with recommendations from FEMA P-1019. In some situations, power serving critical facilities may be disrupted by nearby flooding, even if the facility is not flooded.	FEMA P-1019, <i>Emergency Power Systems for Critical Facilities: A Best Practices Approach to Improving Reliability</i> (2014)
Other Protection Considerations – Protection from High Winds	While elevating equipment will protect it from flooding, elevating equipment can introduce other risks. Equipment mounted in mechanical penthouses can be damaged by the high winds that accompany storms, and equipment that services exterior-mounted elevators in coastal areas can be damaged by storm surge generated by high winds. Penthouses have failed in storm events and allowed rainwater to enter from the top, rendering equipment inoperable. Designers are advised to account for the increased high wind risks associated with elevation as they reduce risks from flooding.	—

**Table 6. Guidance for Specific Components**

Topic	Guidance for Specific Components
Doors and Door Frames	Use stainless steel doors and door frames below the BFE.
Limit Switches	Relocate switches above the BFE using small brackets. Modern controllers use selector tape for landing control systems and require a short length of selector cam for switch activation.
Selector Tape	Use stainless steel selector tape, which is available for most controllers.
Slide and Roller Guides	For hydraulic elevators, use Teflon®-impregnated inserts on slide guides or convert to roller guides to reduce leakage of oil-based products into pits.

Table 6. Guidance for Specific Components (concluded)

Topic	Guidance for Specific Components
Compensation Cables	For traction elevators, remove compensation cables and replace with encapsulated chain systems.
Electrical	Use NEMA 4-rated enclosures, galvanized conduits, and watertight conduits and fittings below the BFE. Locate controls and equipment above the BFE where possible.
Hardware	Use galvanized sill angles and hardware at floors below the BFE.
Maintenance	Paint or coat buffers and all pit steel and hardware with galvanic or rust-preventive paint.

## 7 References

This section lists the references that are cited in this Technical Bulletin. Additional resources related to NFIP requirements are provided in Technical Bulletin 0.

- ANSI (American National Standards Institute). 2012. *Safety Requirements for Industrial Scissors Lifts*. ANSI MH29.1. Available at <https://webstore.ansi.org>.
- ASCE (American Society of Civil Engineers). 2016. *Minimum Design Loads and Associated Criteria for Buildings and Other Structures*. ASCE 7. Available at <https://ascelibrary.org/doi/book/10.1061/9780784414248>.
- ASCE/SEI (American Society of Civil Engineers / Structural Engineering Institute). 2005. *Flood Resistant Design and Construction*. ASCE 24-05. Available at <https://ascelibrary.org/doi/book/10.1061/9780784408186>.
- ASCE/SEI. 2014. *Flood Resistant Design and Construction*. ASCE/SEI 24-14. Available at <https://ascelibrary.org/doi/book/10.1061/9780784413791>.
- ASME (American Society of Mechanical Engineers). 2007. *Safety Code for Elevators and Escalators*. ASME A17.7-2007/CSA B44-07. Available at <https://webstore.ansi.org/Standards/CSA/ASMEA172007CSAB44R2017?source=blog>.
- ASME (American Society of Mechanical Engineers). 2016. *Safety Code for Elevators and Escalators*. ASME A17.1-2016/CSA B44-16. Available at <https://webstore.ansi.org/Standards/ASME/ASMEA172016?source=blog>.
- FEMA (Federal Emergency Management Agency). Various. NFIP Technical Bulletins. Current editions available at <https://www.fema.gov/nfip-technical-bulletins>:
- *User’s Guide to Technical Bulletins*. Technical Bulletin 0.
  - *Openings in Foundation Walls and Walls of Enclosures Below Elevated Buildings in Special Flood Hazard Areas*. Technical Bulletin 1.
  - *Flood Damage-Resistant Materials Requirements for Buildings Located in Special Flood Hazard Areas*. Technical Bulletin 2.
  - *Corrosion Protection for Metal Connectors in Coastal Areas*. Technical Bulletin 8.

- FEMA. 2010. *Substantial Improvement/Substantial Damage Desk Reference*. FEMA P-758. Available at <https://www.fema.gov/media-library/assets/documents/18562>.
- FEMA. 2013. *Reducing Interruptions to Mid- and High-Rise Buildings During Floods*. Recovery Advisory 4 in FEMA P-942, *Mitigation Assessment Team Report: Hurricane Sandy in New Jersey and New York*. Available at <https://www.fema.gov/media-library/assets/documents/30966>.
- FEMA. 2014. *Emergency Power Systems for Critical Facilities: A Best Practices Approach to Improving Reliability*. FEMA P-1019. Available at <https://www.fema.gov/media-library/assets/documents/101996>.
- FEMA. 2018. *Answers to Questions About Substantially Damaged Improved/Damaged Buildings*. FEMA 213. Available at <https://www.fema.gov/media-library/assets/documents/169099>.
- ICC (International Code Council). 2018. *International Building Code*. 2018 IBC. Available at <https://www.iccsafe.org/products-and-services/i-codes/2018-i-codes/ibc/>.
- ICC. 2018. *International Existing Building Code*. Available at <https://www.iccsafe.org/>.
- ICC. 2018. *International Residential Code*. 2018 IRC. Available at <https://www.iccsafe.org/products-and-services/i-codes/2018-i-codes/irc/>.
- NFPA (National Fire Protection Association). 2017. *National Electrical Code*. NFPA 70. Available at <https://www.nfpa.org/codes-and-standards/all-codes-and-standards/list-of-codes-and-standards/detail?code=70>.

